

# INTERSTATE



CONTINUOUS COLD  
FORMED BEAM DESIGN  
WITH INTERLOCKING  
CROSSMEMBERS

LOW PROFILE RADIAL TIRES

LOWBOY ABILITY IN A  
TAG-A-LONG

50,000# CAPACITY

(3) 22,500# AXLES

HUB PILOTED WHEELS

## 50DLA



AIR LIFT THIRD AXLE  
(optional)

Courtesy of MachineMarket

THE  
DEFINITION  
OF VALUE

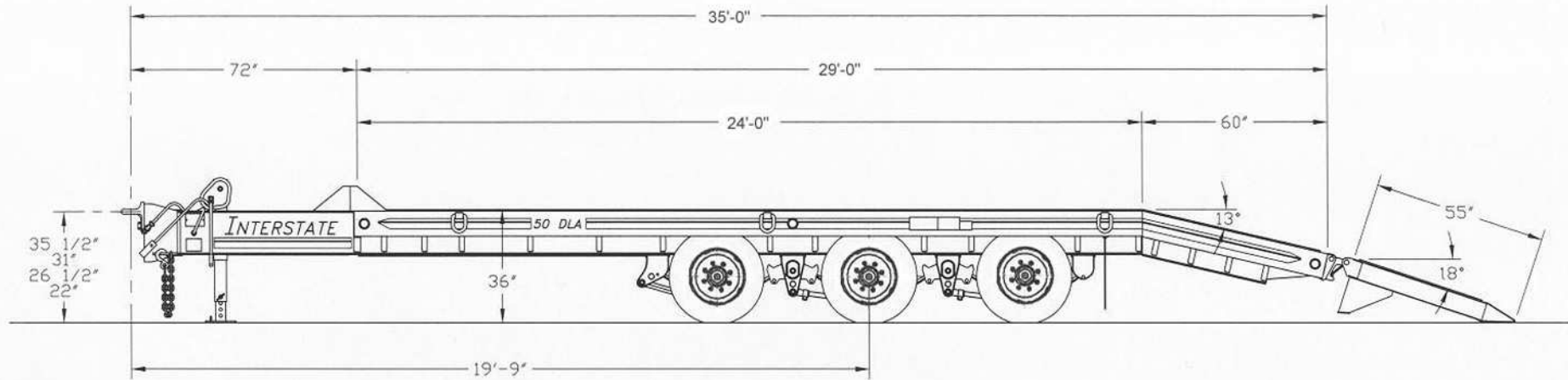

## MODEL 50DLA

CAPACITY: 50,000# @ 55 MPH  
 Trailer Weight: 10,850 lbs.  
 Overall Length: 35'-0"  
 Overall Width: 96"/102"  
 Platform Length: 29'-0"  
 Platform Height: 36"  
 Dovetail Length: 60"  
 Ramp Length: 55"  
 Ramp Width: 22 1/2"  
 Decking: 2" Nominal Hardwood

Main Rails: W14" x 26# A572 Gr 50 - High Tensile  
 Crossmembers: 6" Jr. I Beam A572 Gr. 50 - High Tensile  
 Heavy Duty Axles: (3) 22,500#  
 Heavy Duty Brakes: 12 1/4" x 7 1/2" Air - ABS  
 Heavy Duty Suspension: H9700  
 Tires: (12) 215/75R x 17.5 - 16 Ply Radials  
 Heavy Duty Wheels: 8 Bolt, Hub Piloted  
 Lights & Electric: Sealed Beam System/ICC & Dot approved  
 Hitch: Adjustable Pintle Eye

Heavy Duty Jack: 2 Speed 25,000# Capacity

Your **INTERSTATE** Dealer Is