

INTERSTATE



12BST

**THE
DEFINITION
OF VALUE**

**CONTINUOUS MAIN
BEAM DESIGN**

**HEAVY DUTY SPRING
SUSPENSION**

**HEAVY DUTY ELECTRIC
BRAKES**

DISC TYPE WHEELS

**235/80R16, (E)
Tires**

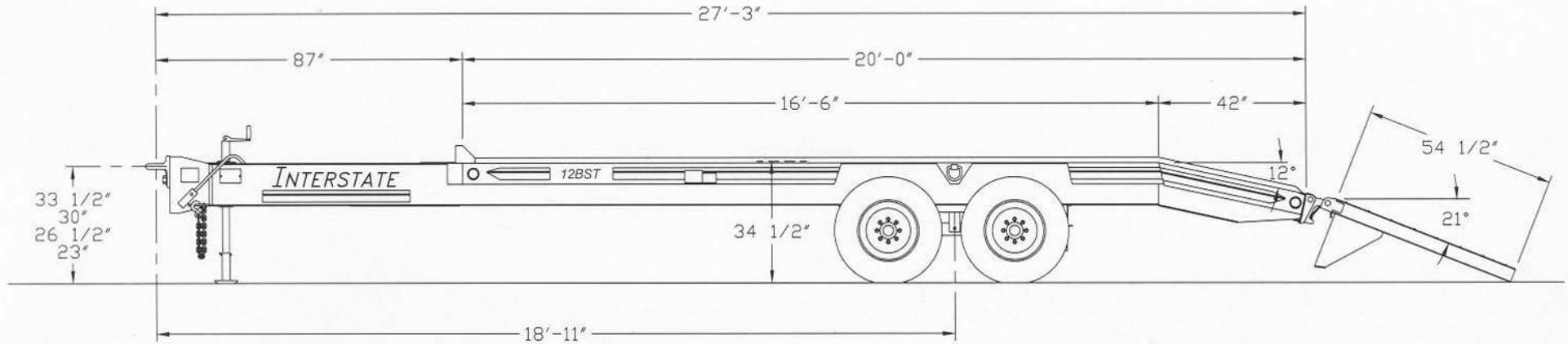

Model: 12BST

CAPACITY:	12,000# @ 65 MPH	Main Rails:	W12" x 16" A572 Gr. 50 - High Tensile
Trailer Weight:	4,575#	Crossmembers:	6" Jr. I Beam - High Tensile
Overall Length:	27' 3"	Heavy Duty Axles:	(2) "Dexter" 6,000# capacity
Overall Width:	96"/102"	Heavy Duty Brakes:	Electric, 12" x 2" Each Wheel
Platform Length:	20' 0"	Jack:	5000# Screw Type
Platform Height:	34"	Heavy Duty Suspension:	Spring Type
Dovetail Length:	42"	Tires:	(4) 235/80R16, (E)
Ramp Length:	54 1/2"	Heavy Duty Wheels:	8 Hole, Steel Disc
Ramp Width:	21 1/2"	Lights & Electric:	Sealed Beam System/ICC & DOT Approved
Decking:	2" Nominal Hardwood	Hitch:	Adjustable Pintle Eye - 4 Position

Gell Cell Break-A-Way Switch System with Battery

Your **INTERSTATE** Dealer Is