

INTERSTATE



20/24DTA

CONTINUOUS MAIN
BEAM WITH
INTERLOCKING
CROSSMEMBERS

DUAL WHEELS &
TANDEM AXLES

ABS

HEAVY DUTY SPRING
SUSPENSION

DISC TYPE WHEELS

THE
DEFINITION
OF VALUE

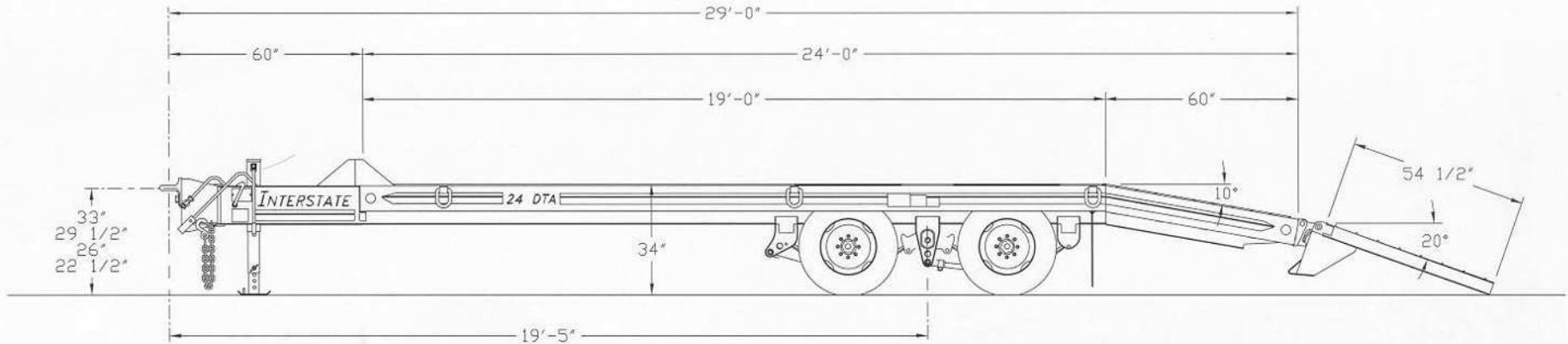

Model 24DTA

CAPACITY: 24,000# @ 65 MPH
 Overall Weight: 6250#
 Overall Length: 29' 0"
 Overall Width: 96"/102"
 Platform Length: 24' 0"
 Platform Height: 34"
 Dovetail Length: 60"
 Ramp Length: 54 1/2"
 Ramp Width: 21 1/2"
 Decking: 2" Nominal Hardwood

Main Rails: W12" x 16# A572 Gr. 50 High Tensile
 Crossmembers: 6" Jr. I Beam A572 Gr. 50 High Tensile
 Heavy Duty Axles: (2) "Dexter" 12,000#
 Heavy Duty Brakes: Air, 12-1/4" x 5" with ABS
 Heavy Duty Suspension: H9700
 Tires: 235/80R16, (E)
 Heavy Duty Wheels: 8 hole "Budd" Type Disc
 Lights & Electric: Sealed Beam System/ICC & DOT Approved
 Hitch: Adjustable Pintle Eye
 Landing Legs: 12,000#

Your **INTERSTATE** Dealer Is