

INTERSTATE

THE
PERFECT
CONNECTION



FEATURES

- EASY ONE-MAN OPERATION
- LOW PROFILE LOAD ANGLE
- TWIN CUSHION CYLINDERS
- SEALED BEAM LIGHTING SYSTEM



20APC

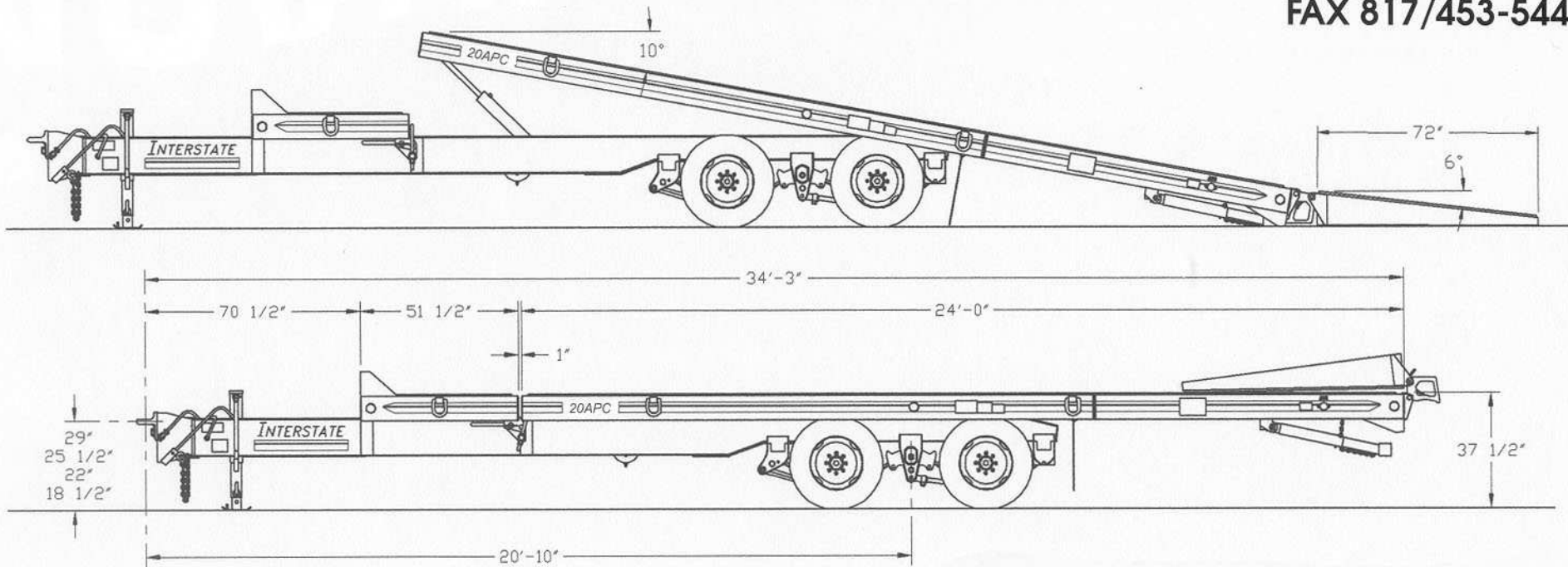

Model: 20APC

CAPACITY:	20,000# @ 65 MPH	Main Rail:	Tilt Bed - W8" x 15# A572 Gr. 50 High Tensile
Overall Weight:	5,950#	Chassis:	W12" x 19# A572, Gr. 50 Hi-Tensile
Overall Length:	34' 4 1/2"	Crossmembers:	Tilt Bed - S6" x 12.5# A572 Gr. 50 High Tensile
Overall Width:	96"/102"	Chassis:	4" x 4" Square Tube A500B
Platform Length:	24' 0"	Heavy Duty Axles:	(2) "Dexter" 10,000#
Stationary Deck:	51 1/2"	Heavy Duty Brakes:	Air, 12-1/4" x 4" with ABS
Platform Height:	38"	Heavy Duty Suspension:	Hutch 9700
Paver Ramps:	72" (spring assisted) (2" nominal hardwood)	Tires:	(8) 235/80R16, (E) Goodyears
Decking:	2" Nominal Hardwood	Heavy Duty Wheels:	8 hole, Steel Disc
Hitch:	Adjustable Pintle Eye	Lights & Electric:	Sealed Beam System/ICC & DOT Approved
Cushion Cylinder:	2 (3 1/2" diameter)	Heavy Duty Jack:	12,000# Drop Leg

Your **INTERSTATE** Dealer Is