

CCH1000

Lifting Capacity : 100t

FULLY HYDRAULIC CRAWLER CRANE

IHI Construction Machinery Limited

CONTENTS

CRANE

- Dimensions / Specifications 1
- Boom And Jib Combination 2
- Boom Rated Lifting Loads 3
- 1m Aux. Jib Rated Lifting Loads 3
- Jib Rated Lifting Loads
 - Boom Length 31~46m 4
 - Boom Length 49~52m 5
- Working Ranges Diagram 6

LUFFING TOWER CRANE

- Dimensions / Specifications 7
- Tower Boom and Jib Combination 8
- Tower Crane Rated Lifting Loads
 - Tower Boom Length 26.5m, 29.5m, 32.5m ... 9
 - Tower Boom Length 35.5m, 38.5m 10
 - Tower Boom Length 41.5m, 44.5m 11
- Working Ranges Diagram 12

CLAMSHELL SPECIFICATION

- Dimensions / Specifications 13
- Bucket Specifications 14
- ◆ Standard Equipment / Optional Specifications 15
- ◆ Transport Dimensions and Weight 16~21
- ◆ Lubricating Oil List 21
- ◆ Painting / Remarks 21

Dimensions / Specifications

(unit : mm)

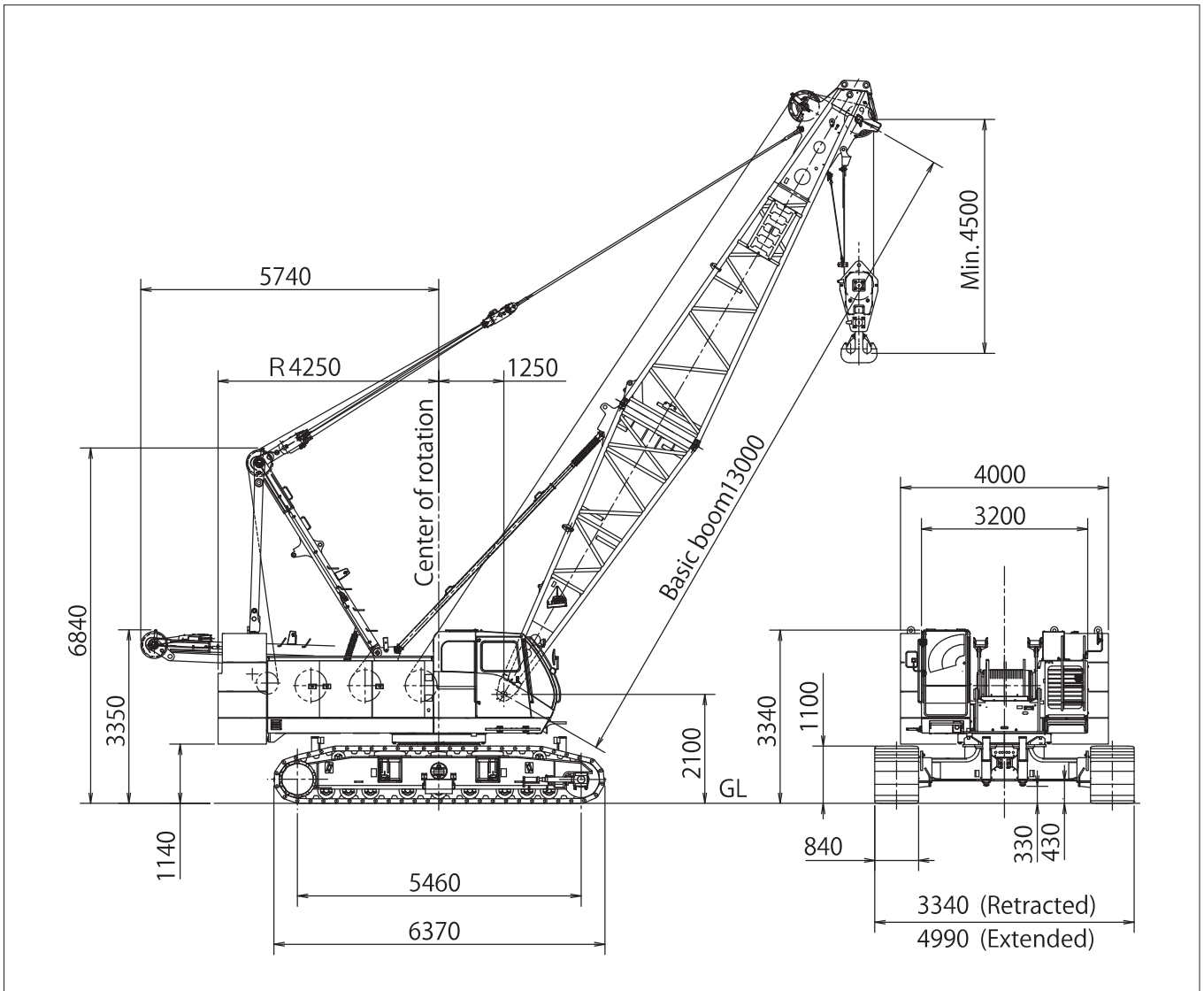

■ CCH1000 Main Specifications

PERFORMANCE		
Slewing speed	2.4min ⁻¹ (constant speed 0.8min ⁻¹)	
Travel speed	※ 1.5/1.0 km/h	
Gradeability	30% (16.7°)	
Engine	Manufacturer	Cummins Inc.
	Model	QSB6.7
	Emission Certification	U.S.EPA Tier3,CARB Tier3,EU Stare III A
	Type	179kW/2000min ⁻¹ (243ps/2000rpm)
	Rated output	6.7 L
	Total displacement	214g/kWh (157g/psh)
	Fuel tank capacity	400 L
	Battery	DC 12V × 120AH 2pcs

■ Crane Specifications

PERFORMANCE		
Maximum lifting capacity × working radius	100ton × 4.0m	
Standard boom length	13m	
Light boom length	61m	
Maximum boom length with Jib boom	77m (49m boom + 22m jib)	
Rope speed	hoisting/lowering	※ 120m/min
	Aux. hoisting/lowering	※ 120m/min
	Boom hoisting/lowering	※ 65m/min
Rope part lines	100t hook	8 part lines
	12t hook	1 part line
	Boom hoist	12 part lines
Line pull	Max. line pull	20t/196kN
	Rated line pull	12t/118kN
Standard counterweight	30.6ton	
Crane total weight	Approx. 87 ton (with 13 m boom) & 100t hook	
Average ground bearing pressure	87kPa (0.89 kgf/c)	

※ The value marked with "※" will be changed according to the loads given

CRANE

Boom And Jib Combination

Boom And Jib Combination

Jib Length (m)	Boom And Jib Combination (m)																
	13	16	19	22	25	28	31	34	37	40	43	46	49	52	55	58	61
Aux.	○	○	○	○	○	○	○	○	○	○	○	○	○	○	○	○	
10							○	○	○	○	○	○	○	○			
16							○	○	○	○	○	○	○	○			
22							○	○	○	○	○	○	○				

Wire Rope

Purpose	Rope dia (mm)	Breaking Strength (kN)	Rope Type	Rope Length
Load hoisting	φ26	651	P·S (19) + 39×P.7	210m
Boom hoisting	φ20	284	IWRC 6×WS (31)	170m
Boom suspension	φ34	1020	IWRC 6×P·WS (36)	—
Jib load hoisting	φ26	567	IWRC 6×P·WS (31)	160m
Jib boom suspension	φ28	585	IWRC 6×Fi (29)	—
Jib strut suspension	φ28	585	IWRC 6×Fi (29)	—

Boom Combination

Boom Section	Boom Length (m)																
	13	16	19	22	25	28	31	34	37	40	43	46	49	52	55	58	61
6m Inner	1	1	1	1	1	1	1	1	1	1	1	1	1	1	1	1	1
3m Insert	—	1	2	1	2	2	1	2	2	1	2	2	1	2	2	1	2
6m Insert	—	—	—	1	1	—	1	1	—	1	1	—	1	1	—	1	1
9m Insert	—	—	—	—	—	1	1	1	2	2	2	3	3	3	4	4	4
7m Outer	1	1	1	1	1	1	1	1	1	1	1	1	1	1	1	1	1

※ The above chart is our recommendation for main boom combination.
Please choose the boom length based on it to meet your requirement.

Jib Combination

Boom Section	Jib Length (m)		
	10	16	22
5m Inner	1	1	1
6m Insert	—	1	2
5m Outer	1	1	1

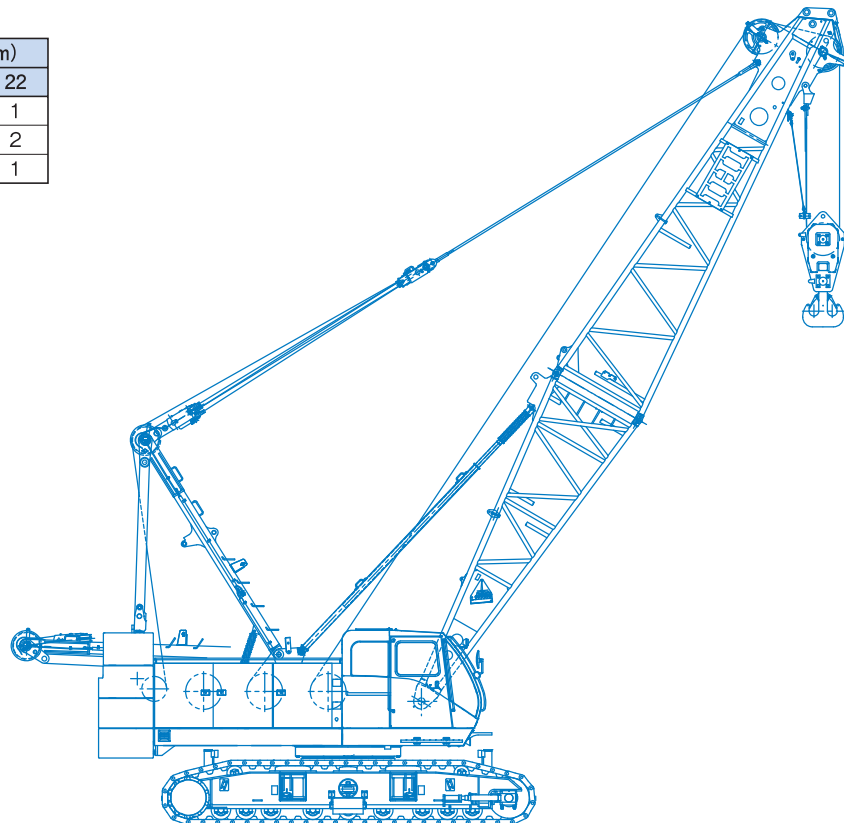

MAIN BOOM RATED LIFTING LOADS

(unit : ton)

Workingradius(m)	Boomlength(m)																
	13.0	16.0	19.0	22.0	25.0	28.0	31.0	34.0	37.0	40.0	43.0	46.0	49.0	52.0	55.0	58.0	61.0
4.0	100.0																
4.5	83.0	83.0															
5.0	74.2	74.0	5.6m×71.0	5.6m×63.4													
6.0	57.3	57.2	57.1	56.9	6.2m×53.8	6.6m×49.0											
7.0	45.1	45.0	44.9	44.7	44.8	44.7	7.2m×42.8	7.8m×37.9									
8.0	37.1	37.0	36.9	36.7	36.7	36.7	36.6	36.5	8.5m×33								
9.0	31.4	31.3	31.2	31.1	31.0	31.0	30.9	30.8	30.7	30.6	9.5m×28.2						
10.0	27.2	27.1	27.0	26.8	26.8	26.7	26.7	26.5	26.5	26.4	26.2	26.2	10.6m×24.0	11.2m×22.0	11.7m×20.6		
12.0	21.3	21.2	21.1	21.0	20.9	20.8	20.7	20.6	20.5	20.4	20.3	20.2	20.1	20.0	19.9	12.3m×18.0	12.7m×15.0
14.0	12.7m×19.8	17.3	17.2	17.1	17.0	16.9	16.8	16.7	16.6	16.5	16.4	16.3	16.2	16.1	16.0	15.9	14.0
16.0		15.3m×15.4	14.4	14.3	14.2	14.1	14.0	13.9	13.8	13.7	13.6	13.5	13.4	13.3	13.2	13.1	12.4
18.0			17.9m×12.4	12.2	12.1	12.0	12.0	11.8	11.7	11.6	11.5	11.4	11.3	11.2	11.1	11.0	10.6
20.0				10.6	10.5	10.4	10.3	10.2	10.1	10.0	9.9	9.8	9.7	9.5	9.4	9.3	9.2
22.0				20.5m×10.3	9.2	9.1	9.1	8.9	8.8	8.7	8.6	8.5	8.4	8.3	8.1	8.0	7.9
24.0					23.1m×8.6	8.1	8.0	7.9	7.8	7.7	7.5	7.4	7.3	7.2	7.1	7.0	6.8
26.0						25.7m×7.3	7.1	7.0	6.9	6.8	6.7	6.6	6.4	6.3	6.2	6.1	6.0
28.0							6.4	6.2	6.1	6.0	5.9	5.8	5.7	5.6	5.4	5.3	5.2
30.0							28.3m×6.3	5.6	5.5	5.4	5.3	5.2	5.1	4.9	4.8	4.6	4.5
32.0								30.9m×5.4	5.0	4.9	4.7	4.6	4.5	4.4	4.2	4.1	3.9
34.0									33.5m×4.6	4.4	4.2	4.1	4.0	3.8	3.7	3.5	3.4
36.0										3.9	3.8	3.6	3.5	3.4	3.3	3.1	2.9
38.0										36.1m×3.9	3.4	3.3	3.1	3.0	2.8	2.7	2.5
40.0											38.7m×3.2	2.9	2.8	2.6	2.4	2.3	2.1
42.0												41.3m×2.7	2.5	2.3	2.1	2.0	1.8
44.0													43.9m×2.1	1.9	1.8	1.6	1.5
46.0														1.7	1.5		

1m AUX. JIB RATED LIFTING LOADS

(unit : ton)

Workingradius(m)	Boomlength(m)																
	13.0	16.0	19.0	22.0	25.0	28.0	31.0	34.0	37.0	40.0	43.0	46.0	49.0	52.0	55.0	58.0	61.0
4.0																	
4.5	4.6m×12.0																
5.0	12.0	5.1m×12.0	5.6m×12.0														
6.0	12.0	12.0	12.0	6.2m×12.0	6.7m×12.0												
7.0	12.0	12.0	12.0	12.0	12.0	7.2m×12.0	7.7m×12.0										
8.0	12.0	12.0	12.0	12.0	12.0	12.0	12.0	8.2m×12.0	8.8m×12.0								
9.0	12.0	12.0	12.0	12.0	12.0	12.0	12.0	12.0	12.0	9.3m×12.0	9.8m×12.0						
10.0	12.0	12.0	12.0	12.0	12.0	12.0	12.0	12.0	12.0	12.0	12.0	10.3m×12.0	10.8m×12.0	11.4m×12.0	11.9m×12.0		
12.0	12.0	12.0	12.0	12.0	12.0	12.0	12.0	12.0	12.0	12.0	12.0	12.0	12.0	12.0	12.0	12.4m×12.0	
14.0	12.0	12.0	12.0	12.0	12.0	12.0	12.0	12.0	12.0	12.0	12.0	12.0	12.0	12.0	12.0	12.0	
16.0		12.0	17.8m×12.0	17.7m×12.0	17.6m×12.0	17.5m×12.0	17.4m×12.0	17.3m×12.0	17.2m×12.0	17.1m×12.0	17.0m×12.0	16.9m×12.0	16.8m×12.0	16.7m×12.0	16.6m×12.0	16.5m×12.0	
18.0		16.6m×12.0	11.8	11.7	11.6	11.5	11.5	11.3	11.2	11.1	11.0	10.9	10.8	10.7	10.6	10.5	
20.0			19.2m×10.8	10.1	10.0	9.9	9.8	9.7	9.6	9.5	9.4	9.3	9.2	9.0	8.9	8.8	
22.0				21.8m×8.9	8.7	8.6	8.6	8.4	8.3	8.2	8.1	8.0	7.9	7.8	7.6	7.5	
24.0					7.7	7.6	7.5	7.4	7.3	7.2	7.0	6.9	6.8	6.7	6.6	6.5	
26.0					24.4m×7.5	6.7	6.6	6.5	6.4	6.3	6.2	6.1	5.9	5.8	5.7	5.6	
28.0						27.0m×6.3	5.9	5.7	5.6	5.5	5.4	5.3	5.2	5.1	4.9	4.8	
30.0							29.6m×5.3	5.1	5.0	4.9	4.8	4.7	4.6	4.4	4.3	4.1	
32.0								4.6	4.5	4.4	4.2	4.1	4.0	3.9	3.7	3.6	
34.0								32.2m×4.5	4.0	3.9	3.7	3.6	3.5	3.3	3.2	3.0	
36.0									34.8m×3.8	3.4	3.3	3.1	3.0	2.9	2.8	2.6	
38.0										37.4m×3.1	2.9	2.8	2.6	2.5	2.3	2.2	
40.0											2.5	2.4	2.3	2.1	1.9	1.8	
42.0												2.0	2.0	1.8	1.6	1.5	
44.0												42.6m×1.9	1.6	1.4			
46.0													45.2m×1.4				

CRANE

JIB RATED LIFTING LOADS

31~37m boom

(unit : ton)

Boom length (m)	31						34						37					
	10		16		22		10		16		22		10		16		22	
Jib length (m)	10°	30°	10°	30°	10°	30°	10°	30°	10°	30°	10°	30°	10°	30°	10°	30°	10°	30°
Jib offset angle	10°	30°	10°	30°	10°	30°	10°	30°	10°	30°	10°	30°	10°	30°	10°	30°	10°	30°
Working radius (m)																		
10.0	10.2m×12.0						10.7m×12.0						11.2m×12.0					
12.0	12.0	13.2m×12.0	12.7m×12.0				12.0	13.7m×12.0	13.2m×12.0				12.0		13.8m×12.0			
14.0	12.0	12.0	12.0			14.7m×10.0	12.0	12.0	12.0			15.2m×10.0	12.0	14.2m×12.0	12.0		15.7m×10.0	
16.0	12.0	12.0	12.0	17.2m×10.0	10.0		12.0	12.0	12.0	17.7m×10.0	10.0	10.0	12.0	12.0	12.0		10.0	
18.0	11.8	12.0	12.0	10.0	9.5		11.7	12.0	12.0	10.0	9.6	21.2m×6.5	11.6	12.0	11.9	18.2m×10.0	9.8	
20.0	10.2	10.5	10.5	9.8	9.0	20.7m×6.5	10.0	10.4	10.4	9.9	9.2	6.5	9.9	10.3	10.3	10.0	9.4	21.7m×6.5
22.0	8.9	9.2	9.2	9.2	8.6	6.5	8.7	9.0	9.0	9.4	8.8	6.5	8.6	9.0	8.9	9.4	9.0	6.5
24.0	7.8	8.0	8.1	8.4	8.2	6.5	7.7	7.9	7.9	8.4	8.1	6.5	7.5	7.8	7.8	8.3	8.0	6.5
26.0	6.9	7.1	7.2	7.5	7.3	6.4	6.8	7.0	7.0	7.4	7.2	6.5	6.6	6.9	6.9	7.3	7.1	6.5
28.0	6.1	6.3	6.4	6.7	6.5	6.2	6.0	6.2	6.3	6.6	6.4	6.3	5.9	6.1	6.2	6.5	6.3	6.3
30.0	5.5	5.7	5.7	6.0	5.9	6.0	5.4	5.5	5.6	5.9	5.8	6.1	5.2	5.4	5.5	5.8	5.7	6.1
32.0	4.9	5.1	5.2	5.4	5.3	5.6	4.8	4.9	5.0	5.3	5.2	5.5	4.7	4.9	4.9	5.2	5.1	5.5
34.0	4.4	4.5	4.7	4.9	4.8	5.1	4.3	4.4	4.5	4.8	4.7	5.0	4.2	4.3	4.4	4.7	4.6	4.9
36.0	4.0	4.1	4.2	4.4	4.4	4.6	3.9	4.0	4.1	4.3	4.2	4.5	3.7	3.9	4.0	4.2	4.1	4.4
38.0	3.6	3.7	3.8	4.0	4.0	4.2	3.5	3.6	3.7	3.9	3.8	4.1	3.4	3.5	3.6	3.8	3.7	4.0
40.0		38.6m×3.5	3.5	3.6	3.6	3.8	3.1	3.2	3.3	3.5	3.5	3.7	3.0	3.1	3.2	3.4	3.4	3.6
42.0			3.2	3.3	3.3	3.5	40.6m×3.0	41.2m×3.0	3.0	3.1	3.2	3.4	2.7	2.7	2.9	3.1	3.1	3.3
44.0			43.8m×2.9	2.9	3.0	3.2			2.7	2.8	2.9	3.1	43.1m×2.5	43.8m×2.4	2.6	2.7	2.8	3.0
46.0				44.7m×2.8	2.8	2.9			2.4	2.5	2.6	2.8			2.3	2.4	2.5	2.7
48.0					2.5	2.6			46.3m×2.4	47.2m×2.3	2.3	2.5			2.0	2.1	2.2	2.4
50.0					49.4m×2.3	2.3					2.1	2.2			49.0m×1.9	49.8m×1.8	2.0	2.1
52.0						50.6m×2.2					1.9	2.0					1.7	1.9
54.0												53.2m×1.8					1.5	1.6
56.0																		
58.0																		

40~46m boom

(unit : ton)

Boom length (m)	40						43						46					
	10		16		22		10		16		22		10		16		22	
Jib length (m)	10°	30°	10°	30°	10°	30°	10°	30°	10°	30°	10°	30°	10°	30°	10°	30°	10°	30°
Jib offset angle	10°	30°	10°	30°	10°	30°	10°	30°	10°	30°	10°	30°	10°	30°	10°	30°	10°	30°
Working radius (m)																		
10.0	11.8m×12.0																	
12.0	12.0						12.3m×12.0						12.8m×12.0					
14.0	12.0	14.7m×12.0	14.3m×12.0				12.0	15.3m×12.0	14.8m×12.0				12.0	15.8m×12.0	15.3m×12.0			
16.0	12.0	12.0	12.0			16.2m×9.5	12.0	12.0	12.0			16.7m×10.0	12.0	12.0	12.0		17.3m×10.0	
18.0	11.5	12.0	11.8	18.7m×10.0	9.5		11.4	11.9	11.7	19.3m×10.0	10.0	10.0	11.2	11.8	11.6	19.8m×10.0	10.0	
20.0	9.8	10.2	10.2	10.0	9.5		9.7	10.1	10.0	10.0	9.6		9.6	10.1	9.9	10.0	9.8	
22.0	8.5	8.9	8.8	9.4	9.0	22.2m×6.5	8.4	8.8	8.7	9.3	8.9	22.8m×6.5	8.3	8.7	8.6	9.2	8.8	23.3m×6.5
24.0	7.4	7.8	7.7	8.2	7.9	6.5	7.3	7.6	7.6	8.1	7.8	6.5	7.2	7.6	7.5	8.0	7.7	6.5
26.0	6.5	6.8	6.8	7.2	7.0	6.5	6.4	6.7	6.7	7.1	6.9	6.5	6.3	6.6	6.6	7.1	6.8	6.5
28.0	5.8	6.0	6.0	6.4	6.2	6.4	5.6	5.9	5.9	6.3	6.1	6.5	5.5	5.8	5.8	6.2	6.0	6.5
30.0	5.1	5.3	5.4	5.7	5.5	6.0	5.0	5.2	5.3	5.6	5.4	5.9	4.9	5.1	5.1	5.5	5.3	5.8
32.0	4.6	4.8	4.8	5.1	5.0	5.4	4.4	4.6	4.7	5.0	4.8	5.3	4.3	4.5	4.6	4.9	4.7	5.2
34.0	4.1	4.2	4.3	4.6	4.5	4.8	3.9	4.1	4.2	4.5	4.3	4.7	3.8	4.0	4.1	4.4	4.2	4.7
36.0	3.6	3.8	3.9	4.1	4.0	4.4	3.5	3.7	3.7	4.0	3.9	4.3	3.4	3.6	3.6	3.9	3.8	4.2
38.0	3.2	3.4	3.5	3.7	3.6	3.9	3.1	3.3	3.3	3.6	3.5	3.8	2.9	3.1	3.2	3.5	3.4	3.7
40.0	2.9	3.0	3.1	3.3	3.3	3.5	2.7	2.9	3.0	3.2	3.1	3.4	2.6	2.7	2.8	3.1	3.0	3.4
42.0	2.5	2.6	2.8	3.0	2.9	3.2	2.3	2.5	2.6	2.8	2.8	3.1	2.2	2.4	2.5	2.7	2.7	3.0
44.0	2.2	2.3	2.5	2.6	2.6	2.9	2.0	2.1	2.3	2.5	2.5	2.8	1.8	2.0	2.1	2.4	2.3	2.7
46.0	45.8m×1.9	2.0	2.2	2.3	2.3	2.6	1.7	1.8	2.0	2.2	2.2	2.5	1.5	1.7	1.8	2.1	2.0	2.3
48.0		46.4m×1.9	1.9	2.0	2.1	2.3	1.4	1.5	1.7	1.9	1.9	2.2			1.5	1.7	1.7	2.0
50.0			1.6	1.7	1.8	2.0			1.4	1.6	1.6	1.9				1.4	1.5	1.8
52.0				1.4	1.6	1.7						1.6						
54.0						1.5												
56.0																		
58.0																		

JIB RATED LIFTING LOADS

49~52m boom

(unit : ton)

Boom length (m)	49						52					
	10		16		22		10		16			
Jib length (m)	10°	30°	10°	30°	10°	30°	10°	30°	10°	30°	10°	30°
Jib offset angle												
Working radius (m)												
10.0												
12.0	13.3m×12.0								13.8m×12.0			
14.0	12.0		15.9m×11.5						12.0			
16.0	12.0	16.3m×11.5	11.5			17.8m×10.0			12.0	16.8m×11.5	16.4m×11.0	
18.0	11.1	11.5	11.5			10.0			11.0	11.5	11.0	
20.0	9.5	10.0	9.8	20.3m×9.0	9.9				9.4	9.9	9.7	20.8m×9.0
22.0	8.2	8.6	8.5	9.0	8.7	23.8m×6.5			8.0	8.5	8.4	9.0
24.0	7.1	7.5	7.4	8.0	7.6	6.5			6.9	7.4	7.3	7.9
26.0	6.2	6.5	6.5	7.0	6.7	6.5			6.0	6.4	6.4	6.9
28.0	5.4	5.7	5.7	6.2	5.9	6.5			5.3	5.6	5.6	6.1
30.0	4.8	5.0	5.0	5.4	5.2	5.8			4.6	4.9	4.9	5.3
32.0	4.2	4.4	4.5	4.8	4.6	5.1			4.1	4.3	4.3	4.7
34.0	3.7	3.9	4.0	4.3	4.1	4.6			3.5	3.8	3.8	4.2
36.0	3.2	3.5	3.5	3.8	3.7	4.1			3.1	3.3	3.4	3.7
38.0	2.8	3.0	3.1	3.4	3.3	3.7			2.6	2.9	2.9	3.3
40.0	2.4	2.6	2.7	3.0	2.9	3.3			2.2	2.5	2.5	2.9
42.0	2.0	2.2	2.3	2.6	2.5	2.9			1.8	2.1	2.1	2.5
44.0	1.7	1.9	2.0	2.3	2.2	2.6			1.5	1.7	1.8	2.1
46.0		1.5	1.7	1.9	1.9	2.2					1.5	1.8
48.0				1.6	1.6	1.9						1.4
50.0						1.6						
52.0												
54.0												
56.0												
58.0												

Notes:

- All rated loads are based on the machine being operated on a firm, level, uniformly supporting surface ground, at any point of 360° around the machine within 78% of tipping load and forward stability factor over 1.15.
- Working radius is the horizontal distance from the center of rotation to the vertical line through the center of gravity of the load.
- To determine the actual load for the main boom, the weight of all lifting devices such as a hook must be reduced from the lifting load.

100ton hock	1.20ton	50ton hock	0.95ton
30ton hock	0.80ton	12ton hock	0.40ton

- When the jib (10.0—22.0m) is equipped, the following weight must be reduced from the lifting load to determine the rated lifting load for the main boom.

Jib length (m)	Aux.Jib	10.0	16.0	22.0
Boom length (m)	13.0~58.0	31.0~52.0	31.0~52.0	31.0~49.0

- To determine the actual load for the aux. jib, the weight of 0.5 ton must be reduced from the lifting load.

- Depending on the number of part lines, the rated lifting load is limited as follows.

Jib length (m) (Offset angle)	Aux.Jib	10.0		16.0		22.0	
		10°	30°	10°	30°	10°	30°
Weight (t)		0,8	1,9	2,0	2,3	2,6	2,8

- The rated load shown in bold lines are based on structural strength factors.

12.0ton	1 part line	44.0ton	4part lines	77.0ton	7part lines
22.0ton	2 part lines	55.0ton	5part lines	90.0ton	8part lines
33.0ton	3 part lines	65.0ton	6part lines		

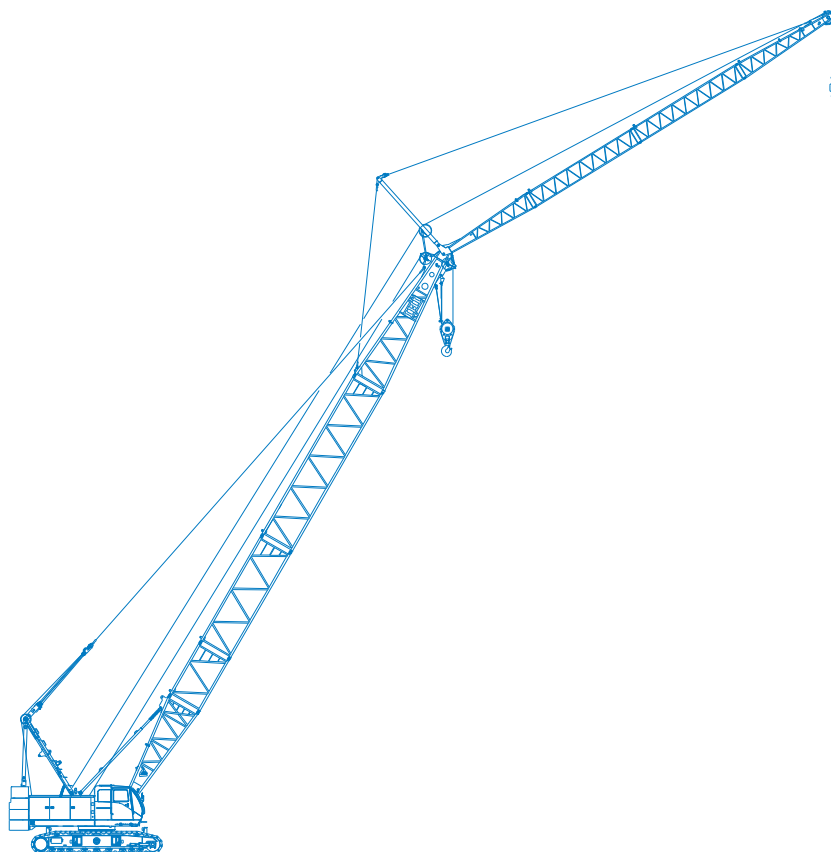

CRANE

Working Ranges Diagram

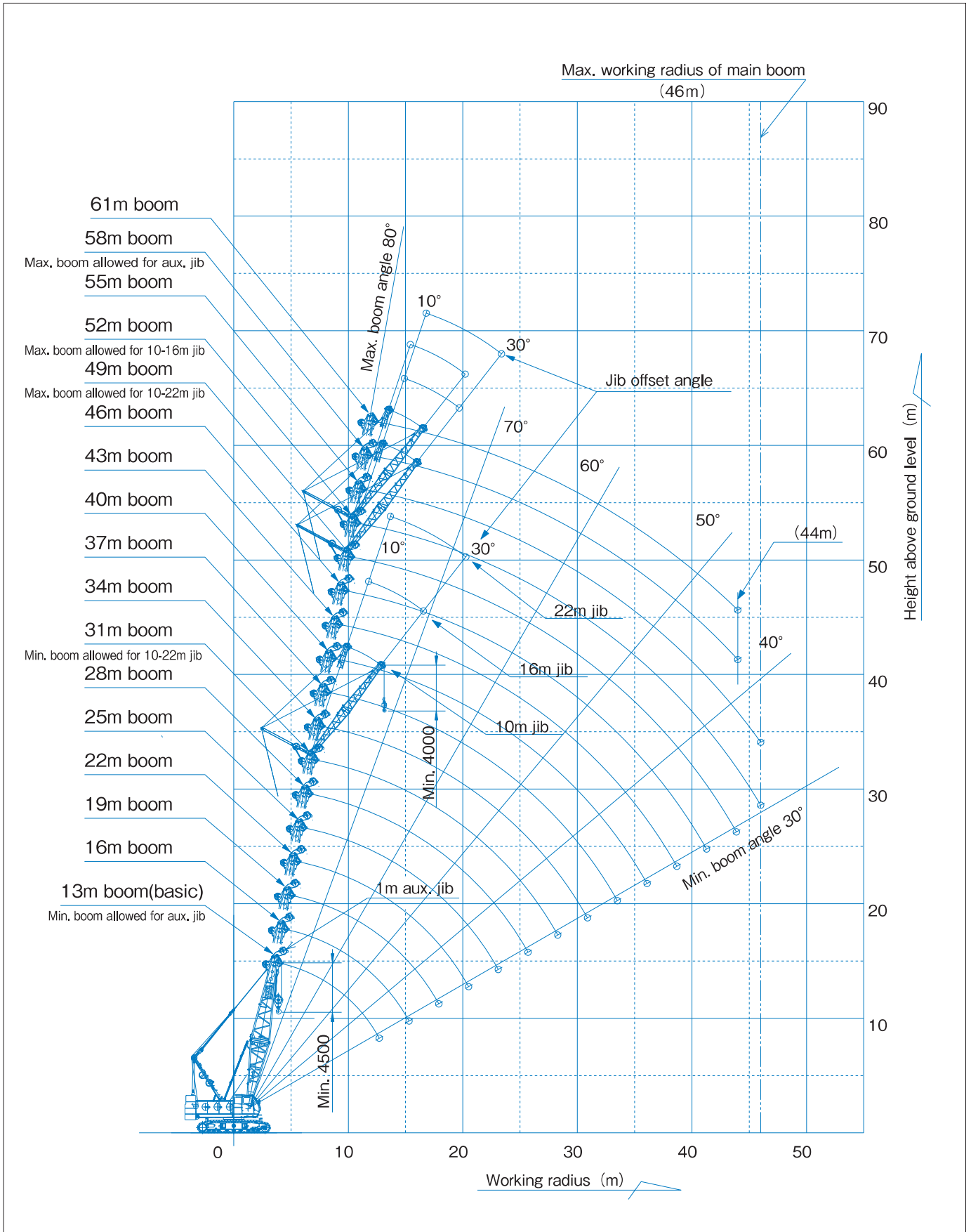

LUFFING TOWER CRANE

CCH1000

Dimensions / Specifications

(unit : mm)

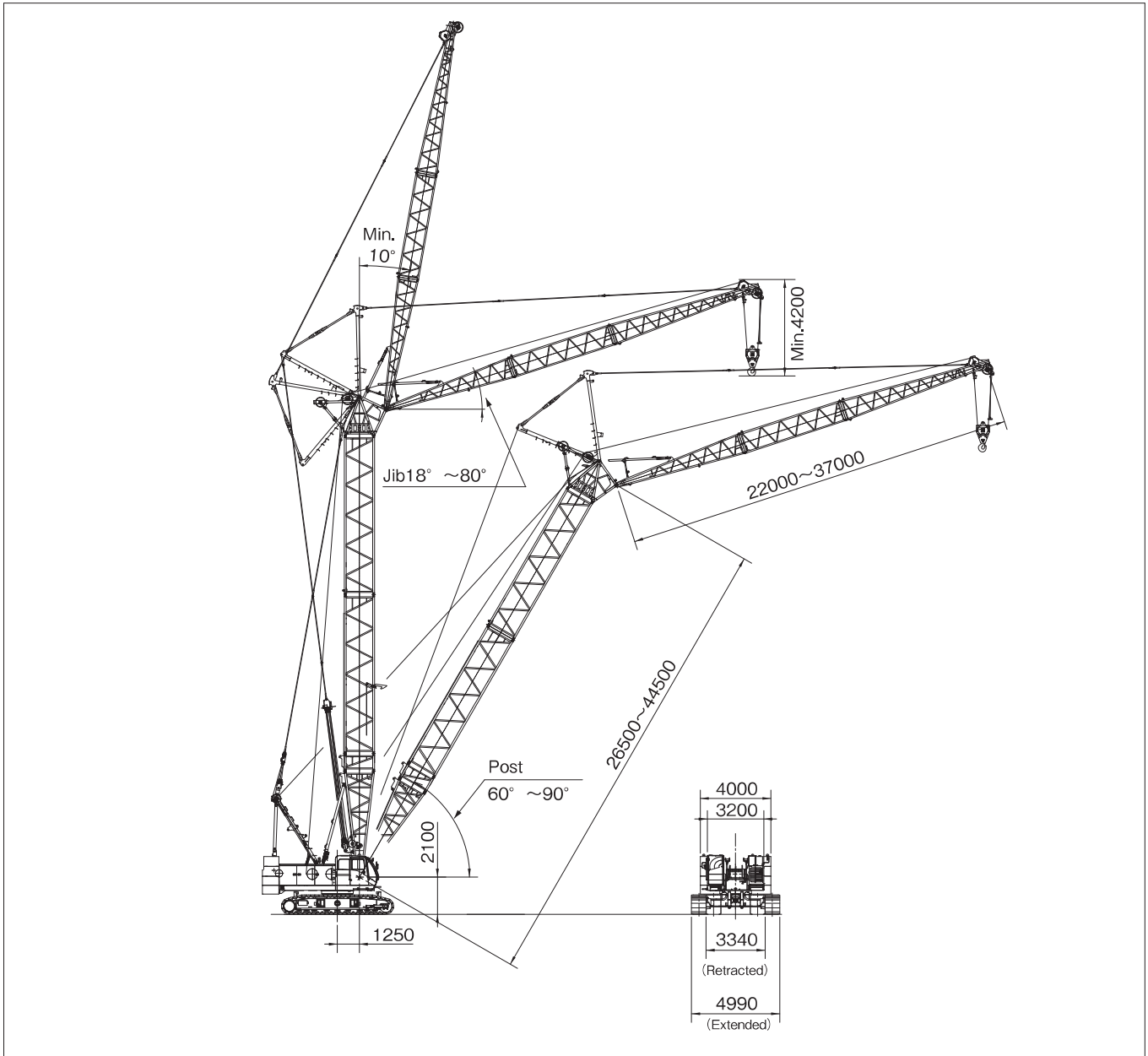

CCH1000 Main Specifications

PERFORMANCE		
Slewing speed	2.4min ⁻¹ (constant speed 0.8min ⁻¹)	
Travel speed	※ 1.5/1.0 km/h	
Gradeability	30% (16.7°)	
Engine	Manufacturer	Cummins Inc.
	Model	QSB6.7
	Emission Certification	U.S.EPA Tier3,CARB Tier3,EU Stare III A
	Type	179kW/2000min ⁻¹ (243ps/2000rpm)
	Rated output	6.7 L
	Total displacement	214g/kWh (157g/psh)
	Fuel tank capacity	400 L
Battery	DC 12V × 120AH 2pcs	

Crane Specifications

PERFORMANCE		
Maximum lifting capacity × working radius	15ton × 14m	
Maximum boom length with Jib boom	78m (44.5m post + 37m jib)	
Rope speed	hoisting/lowering	※ 120m/min
	Boom hoisting/lowering	※ 65m/min
	Jib hoisting/lowering	※ 60m/min
Rope part lines	15t hook	2 part lines
	12t hook	1 part line
	Boom hoist	12 part lines
	Jib hoist	8 part lines
Standard counterweight	30.6ton	
Crane total weight	Approx. 99ton (44.5m post+37m jib+15ton hook)	
Average ground bearing pressure	106kPa (1.08 kgf/c)	

※The value marked with "※" will be changed according to the loads given

LUFFING TOWER CRANE

Post And Jib Combination

Post And Jib Combination

Post Length (m)	Jib Length (m)					
	22	25	28	31	34	37
26.5	⊙					
29.5	⊙	⊙				
32.5	⊙	⊙	⊙			
35.5	⊙	⊙	⊙	⊙		
38.5	⊙	⊙	⊙	⊙	○	
41.5	⊙	○	○	○	○	○
44.5	○	○	○	○	○	○

⊙ mark and ○ mark indicate possible combination of luffing tower.
 ⊙ mark: Inclination of post boom could raise until 60° degree.
 ○ mark: Inclination of post boom could raise until 70° degree.
 ※When using 22m luffing tower jib, it should be equipped with jib weight on the top of boom point.

Post Combination

Post Section	Post Length (m)						
	26.5	29.5	32.5	35.5	38.5	41.5	44.5
6m Inner	1	1	1	1	1	1	1
* 1m Insert	1	1	1	1	1	1	1
* 9m Insert	1	1	1	1	1	1	1
3m Insert	—	1	—	—	1	—	1
6m Insert	—	—	1	—	—	1	1
9m Insert	1	1	1	2	2	2	2
1.5m Outer	1	1	1	1	1	1	1

Note:

- 1.Inner post of 1m and 9m with * marks are attached with guide rail for middle equalizer.
- 2.Inner post of 3m, 6m and 9m are attached with pendant cables for luffing tower jib.

Jib Combination

Boom Section	Jib Length (m)					
	22	25	28	31	34	37
7.5m Inner	1	1	1	1	1	1
3m Insert	—	—	1	—	1	2
6m Insert	1	—	—	1	1	1
9m Insert	—	1	1	1	1	1
8.5m Outer	1	1	1	1	1	1

The combination on the chart is our recommendation and the luffing jib length is at your request among the combination to meet your job site usage.

Wire Rope

Purpose	Rope dia (mm)	Breaking Strength(kN)	Rope Type	Rope Length
Load hoisting	φ 26	598	P.S (19) +39×P.7	260m
Jib hoisting	φ 26	567	IWRC 6×P·WS (31)	190m
Post hoisting	φ 20	284	IWRC 6×WS (31)	170m
Jib suspension	φ 31.5	735	IWRC 6×Fi (29)	—
Strut suspension	φ 31.5	735	IWRC 6×Fi (29)	—
Post suspension	φ 34	1020	IWRC 6×P·WS (36)	—

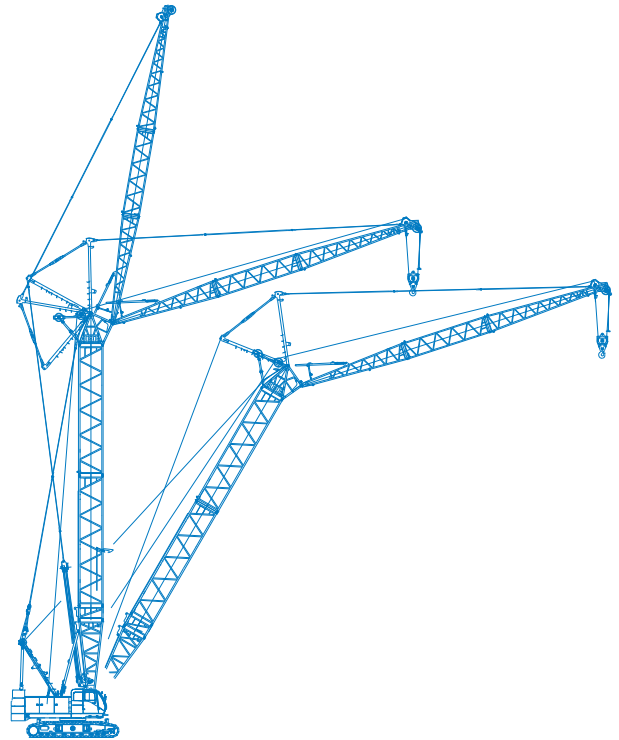

RATED LIFTING LOADS

26.5m post

(unit : ton)

Post Length (m)	26.5			
Jib Length (m)	22.0			
Post Angle	90°	80°	70°	60°
Working radius (m)				
6.0	6.8m×14.6			
7.0	14.6			
8.0	14.6			
9.0	14.6			
10.0	14.6			
12.0	14.6			
14.0	14.6	15.0m×14.4		
16.0	13.5	14.0		
18.0	11.7	12.4		
20.0	10.2	10.9		
22.0	8.8	9.6	22.8m×8.1	
24.0	23.5m×7.7	8.6	7.6	
26.0	★24.0m×7.4	7.7	6.8	
28.0		7.0	6.2	29.9m×4.9
30.0		28.1m×6.9	5.7	4.9
32.0		★28.9m×6.7	5.2	4.5
34.0			32.5m×5.1	4.1
36.0			★33.0m×5.0	3.8
38.0				36.5m×3.7
40.0				★37.1m×3.7
42.0				
44.0				
46.0				
48.0				
50.0				
52.0				

29.5m post

(unit : ton)

Post Length (m)	29.5							
Jib Length (m)	22.0				25.0			
Post Angle	90°	80°	70°	60°	90°	80°	70°	60°
Working radius (m)								
6.0	6.8m×14.6							
7.0	14.6				7.3m×15.0			
8.0	14.6				15.0			
9.0	14.6				15.0			
10.0	14.6				15.0			
12.0	14.6				15.0			
14.0	14.6	15.5m×14.0			15.0			
16.0	13.5	14.0			13.9	16.5m×13.6		
18.0	11.7	13.7			12.1	12.5		
20.0	10.2	12.2			10.6	11.0		
22.0	8.8	10.6	23.8m×7.6		9.5	9.8		
24.0	23.5m×7.7	9.5	7.5		8.5	8.8	25.3m×7.1	
26.0	★24.0m×7.4	8.4	6.7		7.2	8.0	6.9	
28.0		6.8	6.0		26.4m×7.0	7.3	6.2	
30.0		28.6m×6.5	5.4	31.4m×4.4	★26.9m×6.7	6.7	5.7	
32.0		★29.1m×6.2	4.9	4.2		31.5m×6.2	5.3	33.4m×4.3
34.0			33.5m×4.5	3.9		★32.0m×6.0	4.9	4.1
36.0			★34.0m×4.4	3.6			4.5	3.8
38.0				3.2			36.4m×4.4	3.5
40.0				★38.6m×3.2			★36.9m×4.3	3.3
42.0								40.9m×3.2
44.0								★41.4m×3.1
46.0								
48.0								
50.0								
52.0								

32.5m post

(unit : ton)

Post Length (m)	32.5											
Jib Length (m)	22.0				25.0				28.0			
Post Angle	90°	80°	70°	60°	90°	80°	70°	60°	90°	80°	70°	60°
Working radius (m)												
6.0	6.8m×14.6											
7.0	14.6				7.3m×15.0				7.8m×15.0			
8.0	14.6				15.0				15.0			
9.0	14.6				15.0				15.0			
10.0	14.6				15.0				15.0			
12.0	14.6				15.0				15.0			
14.0	14.6				15.0				15.0			
16.0	13.5	13.5			13.9	17.1m×13.0			13.6			
18.0	11.7	11.9			12.1	12.2			11.8	18.1m×12.0		
20.0	10.2	10.4			10.6	10.7			10.3	10.7		
22.0	8.8	9.2			9.5	9.6			9.2	9.4		
24.0	23.5m×7.7	8.2	24.8m×6.7		8.5	8.7			8.3	8.6		
26.0	★24.0m×7.4	7.4	6.2		7.2	7.8	26.3m×6.4		7.5	7.7	27.8m×5.9	
28.0		6.7	5.6		26.4m×7.0	6.6	5.9		6.8	7.1	5.8	
30.0		29.1m×6.3	5.1		★26.9m×6.7	6.6	5.4		29.2m×6.1	6.5	5.3	
32.0		★29.6m×6.0	4.7	32.9m×3.7		6.0	5.0		★29.7m×5.9	6.0	5.0	
34.0			4.3	3.5		★32.5m×5.8	4.6	34.9m×3.6		5.5	4.6	
36.0			34.5m×4.2	3.2			4.3	3.5		34.8m×5.3	4.2	36.8m×3.3
38.0			★35.1m×4.0	2.9			37.4m×4.0	3.2		★35.4m×5.1	3.9	3.1
40.0				39.5m×2.7			★37.9m×3.9	3.0			3.6	2.9
42.0				★40.1m×2.6				2.8			40.2m×3.6	2.7
44.0								42.4m×2.7			★40.8m×3.5	2.5
46.0								★42.9m×2.6				45.3m×2.3
48.0												★45.8m×2.3
50.0												
52.0												

Notes:

1. All rated loads are based on the machine being operated on a firm, level, uniformly supporting surface ground, at any point of 360° around the machine within 78% of tipping load and forward stability factor over 1.15.
2. The determine actual lifting loads, the weight of all lifting device such as hook must be reduced from the lifting loads.
15t hook...0.80t 12.0t hook...0.40t
3. Depending on the number of part lines, rated lifting loads are limited as follows;
Upto 12.0t...1 part line Upto 15.0t...2 part line
4. The Angle formed by the center line of post and luffing jib (offset angle) should not be always below 10 degrees.
5. The Angle formed by the center line of luffing jib and ground line should not be below 18 degrees.
6. Star ★marked working radius indicates the Max.working radius under a condition of 1 part line.
7. When using 22m luffing tower jib, it should be equipped with jib weight on the top of boom point.

LUFFING TOWER CRANE

RATED LIFTING LOADS

35.5m post

(unit : ton)

Post Length (m)	35.5															
	22.0				25.0				28.0				31.0			
Jib Length (m)																
Post Angle	90°	80°	70°	60°	90°	80°	70°	60°	90°	80°	70°	60°	90°	80°	70°	60°
Working radius (m)																
6.0	6.8m×14.6															
7.0	14.6				7.3m×15.0				7.8m×15.0							
8.0	14.6				15.0				15.0				8.3m×13.5			
9.0	14.6				15.0				15.0				13.5			
10.0	14.6				15.0				15.0				13.5			
12.0	14.6				15.0				15.0				13.5			
14.0	14.6				15.0				15.0				13.5			
16.0	13.5	16.6m×13.0			13.9	17.6m×12.5			13.6				13.5			
18.0	11.7	11.7			12.1	12.1			11.8	18.6m×11.3			11.8	19.6m×10.5		
20.0	10.2	10.2			10.6	10.5			10.3	10.4			10.4	10.2		
22.0	8.8	9.2			9.5	9.4			9.2	9.3			9.2	9.1		
24.0	23.5m×7.7	8.2	25.9m×6.2		8.5	8.5			8.3	8.4			8.3	8.2		
26.0	★24.0m×7.4	7.4	6.1		7.2	7.7	27.4m×5.9		7.5	7.6			7.5	7.5		
28.0		6.7	5.4		26.4m×7.0	7.0	5.8		6.8	6.9	28.9m×5.3		6.8	6.8		
30.0		29.6m×6.1	4.8		★26.9m×6.7	6.4	5.2		29.2m×6.1	6.3	5.1		6.2	6.2	30.4m×4.8	
32.0		★30.2m×5.9	4.4			5.8	4.8		★29.7m×5.9	5.8	4.7		5.3	5.7	4.5	
34.0			4.0	34.4m×3.1		32.5m×5.7	4.4			5.4	4.3		32.1m×5.3	5.3	4.2	
36.0			35.5m×3.7	2.9		★33.0m×5.5	4.1	36.4m×3.2		35.3m×5.1	4.0		★32.6m×5.1	4.9	3.9	
38.0			★36.1m×3.6	2.7			3.8	3.0		★35.9m×5.0	3.7	38.3m×2.8		4.6	3.6	
40.0				2.4			38.4m×3.7	2.7			3.4	2.6		38.2m×4.5	3.3	40.2m×2.4
42.0			41.0m×2.3			★38.9m×3.6	2.5			41.3m×3.3	2.4		★38.7m×4.4	3.1	2.2	
44.0			★41.6m×2.2				43.9m×2.3			★41.8m×3.2	2.2			2.9	2.1	
46.0							★44.4m×2.3					2.0		44.1m×2.9	1.9	
48.0												46.8m×1.8		★44.6m×2.8	1.7	
50.0												★47.3m×1.8			49.6m×1.6	
52.0															★50.1m×1.6	

38.5m post

(unit : ton)

Post Length (m)	38.5																		
	22.0				25.0				28.0				31.0				34.0		
Jib Length (m)																			
Post Angle	90°	80°	70°	60°	90°	80°	70°	60°	90°	80°	70°	60°	90°	80°	70°	60°	90°	80°	70°
Working radius (m)																			
6.0	6.8m×14.6																		
7.0	14.6				7.3m×15.0				7.8m×15.0										
8.0	14.6				15.0				15.0				8.3m×13.5				8.9m×11.5		
9.0	14.6				15.0				15.0				13.5				11.5		
10.0	14.6				15.0				15.0				13.5				11.5		
12.0	14.6				15.0				15.0				13.5				11.5		
14.0	14.6				15.0				15.0				13.5				11.5		
16.0	13.4	17.1m×12.4			13.9				13.6				13.5				11.5		
18.0	11.6	11.6			12.0	18.1m×11.8			11.8	19.1m×11.0			11.8				11.5		
20.0	10.1	10.1			10.5	10.4			10.3	10.4			10.4	20.2m×10.2			10.2	21.2m×9.5	
22.0	8.9	9.0			9.3	9.3			9.2	9.2			9.2	9.1			9.1	9.0	
24.0	23.5m×7.8	8.0			8.4	8.3			8.3	8.3			8.3	8.2			8.2	8.1	
26.0	★24.0m×7.8	7.2	26.9m×5.5		7.3	7.5			7.5	7.5			7.5	7.4			7.3	7.3	
28.0		6.5	5.1		26.4m×7.0	6.8	5.3		6.8	6.7	29.9m×4.9		6.8	6.7			6.6	6.6	
30.0		5.9	4.6		★26.9m×6.8	6.3	4.9		29.2m×6.1	6.2	4.9		6.2	6.1	31.4m×4.4		6.1	6.0	
32.0		30.2m×5.9	4.2			5.8	4.5		★29.7m×5.9	5.7	4.5		5.3	5.6	4.3	5.6	5.6	32.9m×4.0	
34.0		★30.7m×5.7	3.8	35.9m×2.5		33.0m×5.5	4.1			5.2	4.1		32.1m×5.3	5.2	3.9	5.1	5.1	3.8	
36.0			3.5	2.5		★33.5m×5.3	3.9	37.9m×2.6		35.9m×4.9	3.7		★32.6m×5.1	4.8	3.6	34.9m×4.5	4.8	3.6	
38.0			36.6m×3.4	2.3			3.6	2.6		★36.4m×4.8	3.4	39.8m×2.2		4.5	3.4	★35.4m×4.4	4.4	3.3	
40.0			★37.1m×3.3	2.1			39.4m×3.3	2.4			3.2	2.2		38.7m×4.3	3.1		4.1	3.0	
42.0				1.9			★40.0m×3.2	2.2			3.0	2.0		★39.2m×4.2	2.9		41.6m×3.9	2.8	
44.0			42.5m×1.8					2.0			42.3m×2.9	1.9			2.7		★42.1m×3.8	2.6	
46.0			★43.1m×1.7					45.4m×1.9			★42.8m×2.8	1.7			45.1m×2.6			2.4	
48.0								★45.9m×1.8				1.5			★45.7m×2.5			2.2	
50.0												48.3m×1.5						★48.5m×2.2	
52.0												★48.8m×1.4							

RATED LIFTING LOADS

41.5m post

(unit : ton)

Post Length (m)	41.5																			
	22.0				25.0			28.0			31.0			34.0			37.0			
	90°	80°	70°	60°	90°	80°	70°	90°	80°	70°	90°	80°	70°	90°	80°	70°	90°	80°	70°	
6.0	6.8m×14.6																			
7.0	14.6				7.3m×15.0			7.8m×15.0												
8.0	14.6				15.0			15.0			8.3m×13.5			8.9m×11.5						
9.0	14.6				15.0			15.0			13.5			11.5			9.4m×9.5			
10.0	14.6				15.0			15.0			13.5			11.5			9.5			
12.0	14.6				15.0			15.0			13.5			11.5			9.5			
14.0	14.6				15.0			15.0			13.5			11.5			9.5			
16.0	13.4	17.6m×11.8			13.9			13.6			13.5			11.5			9.5			
18.0	11.6	11.4			12.0	18.6m×11.3		11.8	19.6m×10.5		11.8			11.5			9.5			
20.0	10.1	10.0			10.5	10.3		10.3	10.2		10.4	20.7m×9.6		10.2	21.7m×8.6		9.1			
22.0	8.9	8.8			9.3	9.2		9.2	9.1		9.2	8.8		9.1	8.5		8.7	22.7m×8.2		
24.0	23.5m×7.8	7.9			8.4	8.2		8.3	8.0		8.3	7.9		8.2	7.6		8.1	7.7		
26.0	★24.0m×7.6	7.1	27.9m×4.9		7.3	7.3		7.5	7.3		7.5	7.1		7.3	6.9		7.4	6.9		
28.0		6.4	4.9		26.4m×7.0	6.7	29.4m×4.8	6.8	6.6		6.8	6.5		6.6	6.4		6.7	6.3		
30.0		5.8	4.4		★26.9m×6.8	6.2	4.7	29.2m×6.1	6.1	30.9m×4.4	6.2	6.0		6.1	5.9		6.2	5.8		
32.0		3.0	3.9			5.7	4.3	★29.7m×5.9	5.6	4.2	5.3	5.5	32.4m×4.0	5.6	5.4	33.9m×3.6	5.7	5.3		
34.0		★31.2m×5.4	3.6			33.5m×5.3	4.0		5.1	3.8	32.1m×5.3	5.0	3.7	5.1	5.0	3.6	5.2	4.9	35.4m×3.3	
36.0			3.3	37.4m×2.0		★34.1m×5.2	3.6		4.8	3.5	★32.6m×5.1	4.7	3.4	34.9m×4.5	4.6	3.3	4.7	4.5	3.2	
38.0			3.0	37.6m×3.0	1.9		3.3		3.6	4.4	3.2		4.4	3.2	★35.4m×4.4	4.3	3.0	37.8m×4.0	4.2	2.9
40.0			★38.1m×2.9	1.7			3.1		★36.9m×4.7	3.0		39.2m×4.2	2.9		4.0	2.8	★38.3m×3.8	3.9	2.7	
42.0				1.5				40.5m×3.1		2.8		★39.8m×4.1	2.7		3.7	2.6		3.5	2.4	
44.0				1.3				★41.0m×3.0			43.3m×2.7		2.5		42.1m×3.7	2.4		3.4	2.2	
46.0				★44.6m×1.2							★43.8m×2.6		2.3		★42.6m×3.6	2.2		44.9m×3.2	2.1	
48.0													46.2m×2.3			2.0		★45.5m×3.1	1.9	
50.0													★46.7m×2.2			49.0m×1.9			1.7	
52.0																★49.5m×1.9			51.9m×1.7	
54.0																			★52.0m×1.6	

44.5m post

(unit : ton)

Post Length (m)	44.5																		
	22.0				25.0			28.0			31.0			34.0			37.0		
	90°	80°	70°	60°	90°	80°	70°	90°	80°	70°	90°	80°	70°	90°	80°	70°	90°	80°	70°
6.0	6.8m×14.6																		
7.0	14.6				7.3m×15.0			7.8m×15.0											
8.0	14.6				15.0			15.0			8.3m×13.5			8.9m×11.5					
9.0	14.6				15.0			15.0			13.5			11.5			9.4m×9.5		
10.0	14.6				15.0			15.0			13.5			11.5			9.5		
12.0	14.6				15.0			15.0			13.5			11.5			9.5		
14.0	14.6				15.0			15.0			13.5			11.5			9.5		
16.0	13.4				13.9			13.6			13.5			11.5			9.5		
18.0	11.6	18.1m×10.9			12.0	19.1m×10.7		11.8			11.8			11.5			9.5		
20.0	10.1	9.6			10.5	10.0		10.3	20.2m×9.7		10.4	21.2m×9.1		10.2			9.1		
22.0	8.9	8.5			9.3	8.9		9.2	8.7		9.2	8.7		9.1	22.2m×8.5		8.7	23.2m×7.9	
24.0	23.5m×7.8	7.6			8.4	8.0		8.3	7.8		8.3	7.8		8.2	7.5		8.1	7.6	
26.0	★24.0m×7.6	6.9			7.3	7.2		7.5	7.1		7.5	7.0		7.3	6.8		7.4	6.8	
28.0		6.2	28.9m×4.3		26.4m×7.0	6.6		6.8	6.4		6.8	6.4		6.6	6.2		6.7	6.2	
30.0		5.7	4.1		★26.9m×6.8	6.0	30.4m×4.3	29.2m×6.1	5.9	31.9m×3.9	6.2	5.8		6.1	5.7		6.2	5.6	
32.0		31.2m×5.4	3.7			5.5	4.0	★29.7m×5.9	5.4	3.8	5.3	5.4	33.4m×3.6	5.6	5.3		5.7	5.2	
34.0		★31.7m×5.3	3.4			5.2	3.7		5.0	3.6	32.1m×5.3	5.0	3.5	5.1	4.9	34.9m×3.2	5.2	4.8	
36.0			3.1		34.1m×5.2	3.4		4.6	3.3	★32.6m×5.1	4.6	3.1	34.9m×4.5	4.5	3.1	4.7	4.4	36.4m×2.9	
38.0			2.9		★34.6m×5.1	3.2		36.9m×4.4	3.0		4.3	2.9	★35.4m×4.4	4.2	2.8	37.8m×4.0	4.1	2.6	
40.0			3.0	38.6m×2.8			2.9	★37.4m×4.3	2.9		39.8m×4.0	2.7		3.9	2.6	★38.3m×3.8	3.8	2.4	
42.0			★39.2m×2.7				41.5m×2.7		2.6		★40.3m×4.0	2.5		3.6	2.4		3.5	2.2	
44.0							★42.0m×2.7		2.4			2.3		42.6m×3.5	2.2		3.2	2.0	
46.0									44.3m×2.3			2.1		★43.1m×3.4	2.0		45.5m×3.1	1.8	
48.0									★44.9m×2.3					47.2m×2.0	1.8		★46.0m×3.0	1.6	
50.0														★47.7m×1.9				1.5	
52.0																	★50.6m×1.6		1.3

LUFFING TOWER CRANE

Working Ranges Diagram

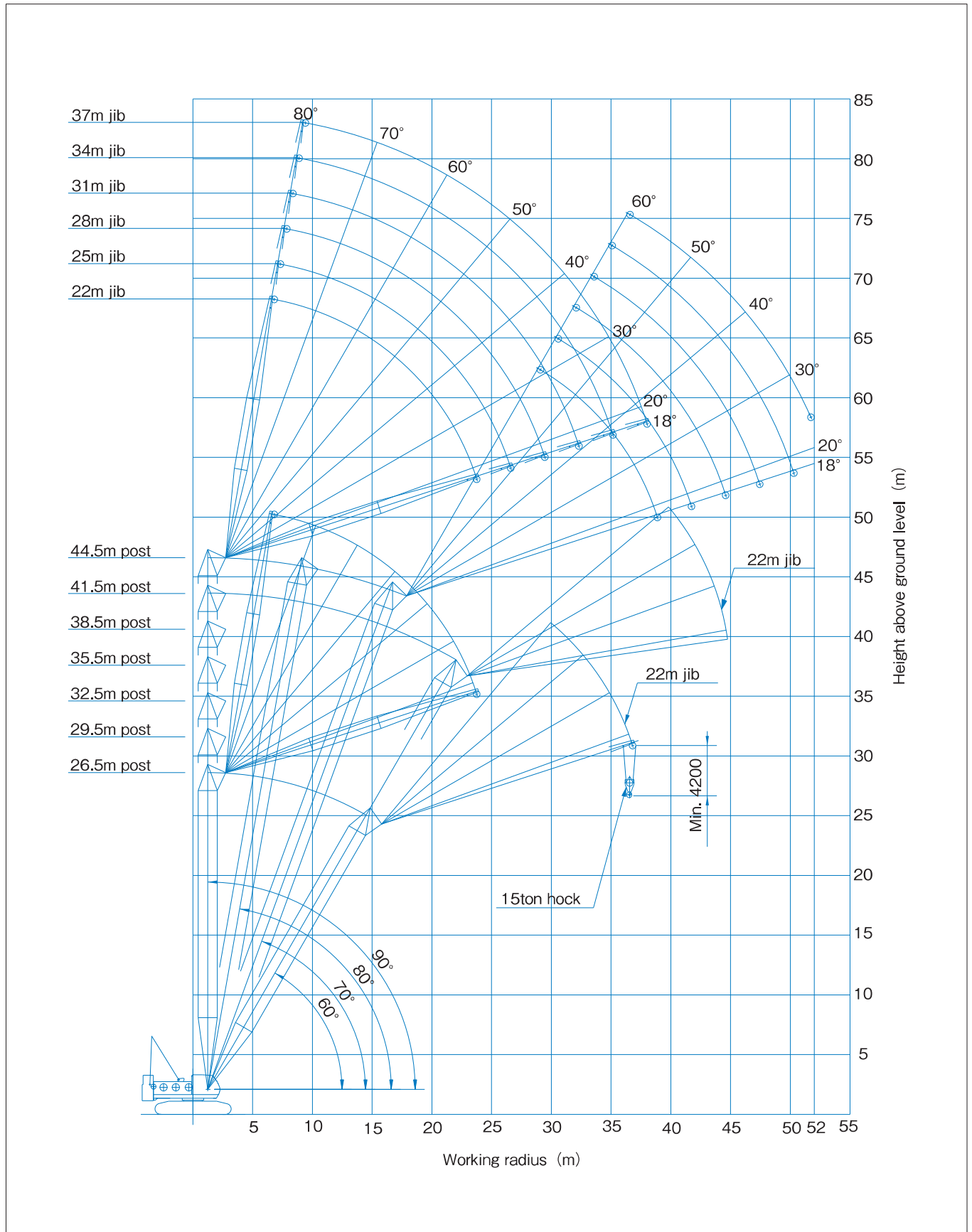

CLAMSHELL SPECIFICATION

CCH1000

Dimensions / Specifications

(unit : mm)

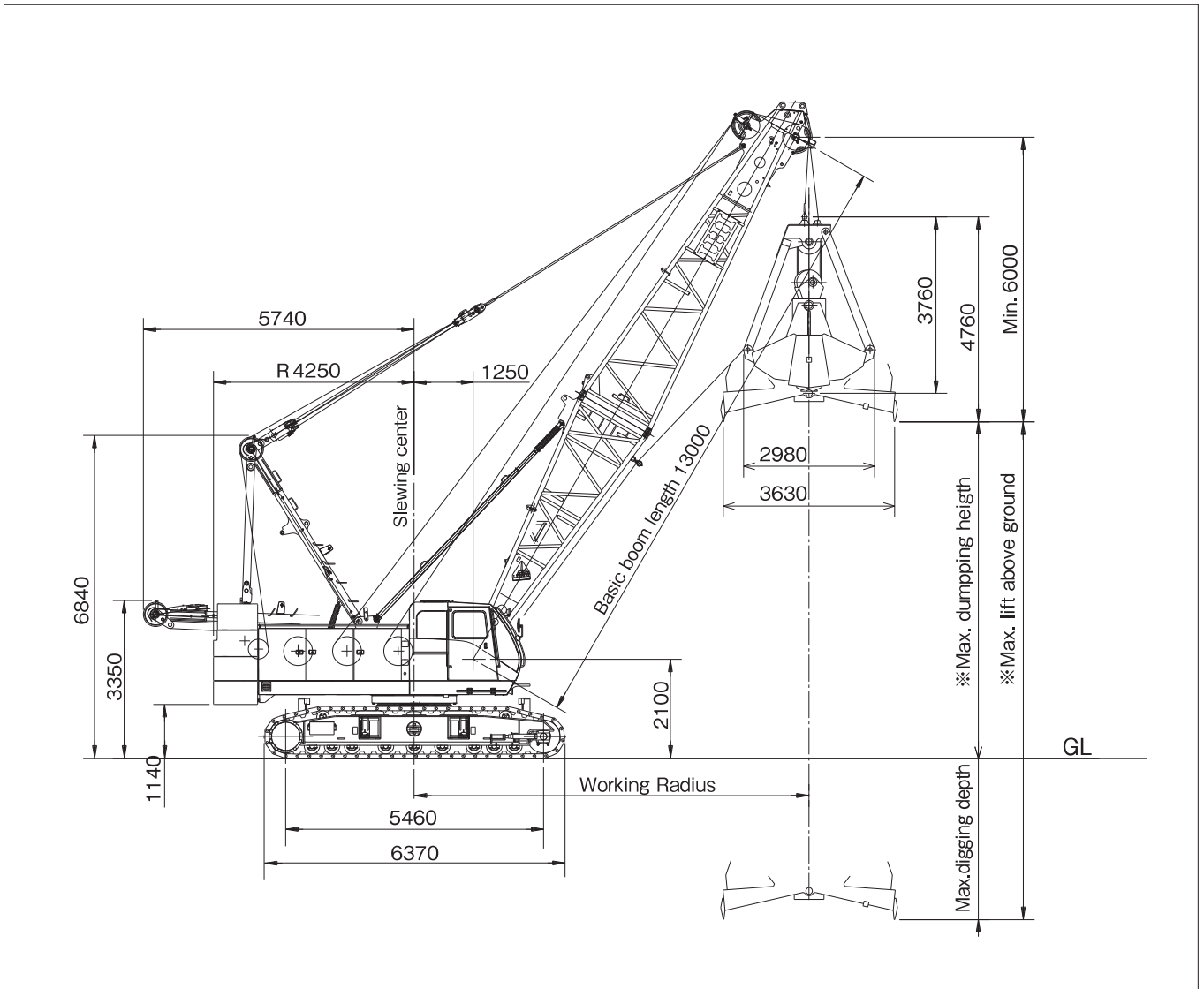

CCH1000 Main Specifications

PERFORMANCE		
Slewing speed	2.4min ⁻¹ (constant speed 0.8min ⁻¹)	
Travel speed	※ 1.5/1.0 km/h	
Gradeability	30% (16.7°)	
Engine	Manufacturer	Cummins Inc.
	Model	QSB6.7
	Emission Certification	U.S.EPA Tier3,CARB Tier3,EU Stare III A
	Type	179kW/2000min ⁻¹ (243ps/2000rpm)
	Rated output	6.7 L
	Total displacement	214g/kWh (157g/ps)
	Fuel tank capacity	400 L
	Battery	DC 12V × 120AH 2pcs

Clamshell Specifications

PERFORMANCE		
Maximum lift above ground		35m
Rope speed	Bucket closing	※ 120m/min
	Bucket holding	※ 120m/min
	Boom hoist /lowering	※ 65m/min
Rope part lines	Bucket closing	6 part lines
	Bucket holding	1 part line
	Boom hoist /lowering	12 part lines
Maximum lifting capacity		10ton (Bucket weight+Load)
Standard counterweight		30.6ton
Crane total weight		Approx. 97 ton(13 m boom+2.5m ³ bucket)
Average ground bearing pressure		91kPa (0.93 kgf/c)

※The value marked with "※" will be changed according to the loads given

CLAMSHELL SPECIFICATION

Clamshell Bucket Specification

Clamshell Bucket Specification

Classifications	Capacity (m³)	Weight (ton)	Classifications
Option	1.6	6.2	Heavy digging (Dredging)
Standard	2.5	5.5	General digging · Heavy duty
Option	3.0	4.5	Medium duty (Specific gravity 1.2-1.5)
Option	4.0	4.0	Medium duty (Specific gravity under 1,2)
Option	5,0	4,0	Medium duty (Specific gravity under 1,0)

Wire Rope

Purpose	Rope dia (mm)	Breaking Strength (kN)	Rope Type	Standard Rope Length
Bucket closing	φ 26	567	IWRC 6×P · WS (31)	82m
Bucket suspension	φ 26	567	IWRC 6×P · WS (31)	62m
Boom hoist	φ 20	284	IWRC 6×WS (31)	170m
Boom suspension	φ 34	1020	IWRC 6×P · WS (36)	—
Hydraulic tugline	φ 10	54	6×19	50m

Working Radius And Rated Loads

Boom length (m)	13				16				19				22				25			
	35°	45°	55°	65°	35°	45°	55°	65°	35°	45°	55°	65°	35°	45°	55°	65°	35°	45°	55°	65°
Working radius (m)	12.4	11.0	9.3	7.4	14.9	13.1	11.0	8.6	17.3	15.2	12.7	9.9	19.8	17.4	14.5	11.2	22.2	19.5	16.2	12.4
Rated lifting loads (ton)	10.0	10.0	10.0	10.0	10.0	10.0	10.0	10.0	10.0	10.0	10.0	10.0	9.7	10.0	10.0	10.0	8.2	9.8	10.0	10.0
Boom point height (m)	9.2	11.0	12.5	13.7	11.0	13.1	15.0	16.4	12.7	15.3	17.4	19.2	14.4	17.4	19.9	21.9	16.1	19.5	22.4	24.6
Max. dumping height (m)	3.2	5.0	6.5	7.7	5.0	7.1	9.0	10.4	6.7	9.3	11.4	13.2	8.4	11.4	13.9	15.9	10.1	13.5	16.4	18.6
Max. digging depth (m)	31.8	30.0	28.5	27.3	30.0	27.9	26.0	24.6	28.3	25.8	23.6	21.8	26.6	23.6	21.1	19.1	24.9	21.5	18.6	16.4

Note:

1. The maximum boom length is 25 meters.
2. The rated lifting load indicates the maximum lifting weight of a bucket and its content, Select an appropriate bucket depending on content, so as not to exceed the rated lifting load.
3. The working radius refers to the horizontal distance from the center of swinging to the vertical line through the center of the bucket.
4. Maximum dumping height depends on the height of a bucket attached. In the chart, top clearance of 6 meters is assumed.
5. Maximum digging depth is the value calculated by subtracting maximum dumping height from the maximum lifting range of 35 meters.
6. The aux. jib cannot be used for bucket work.
7. When lowering a bucket using half brake, ensure that the drop height is about 10 meters or less. Use powered lowering as well as free fall when the drop height is higher than 10 meters.
8. The maximum weight of a bucket is 6,2 tons, but it is necessary to use a lighter bucket depending on work cycle and drop height.
9. Avoid sudden acceleration or deceleration while slewing the machine, which would apply dragging the load sideways to the boom.
Be careful especially when a longer boom is used. Note:

STANDARD EQUIPMENT

■ Safety Devices

- Moment Limiter :Over-load prevention device.
Alarm at 90%,automatic stop at 100%
- Hook over-winding :Alarm and automatic stopper
- Boom over-hoisting :Automatic stopper
- Boom 2nd over-hoisting :All winch function(non resettable)
- Boom backstopper :Double-stem telescopic
- Swing lock :Pin-lock type
- Main and Auxiliary drum lock :Pawl type
- Boom hoisting drum lock :Pawl type
- Lever lock :Remote control circuit line cut off
- Automatic brake system
- Slewing warning buzzer(with voice alarm)
- Travel warning buzzer(with voice alarm)
- Engine start voice alarm · Switch of emergency stop the engine
- Hydraulic safety valves

■ Instrument

- Tachometer(displayed by Moment Limiter)
- Hour meter
- Hydraulic pressure gauge for control circuit
- Fuel level gauge
- Engine coolant temperature gauge(indicated by OK monitor)
- Engine diagnostic monitor

■ Auxiliary DEVICE

- Speed control for slewing
- Speed control for winch
- Pump power shift device
- Remote controller for jack and crawler connect cylinder

■ Lighting

- Work light :24V x 80W
- Room light :24V x 10W

■ Others

- Air conditioner
- Front windshield wiper
- Ceiling wiper
- Sun shade
- Sun visor
- Storage pouch
- Tool box
- Reclining operator's seat
- Floor mat
- Step for operator's cab(retractable type)
- Radio
- Cigarette lighter
- Rear view mirrors(on both sides)
- Warning horn
- Electric fuel pump
- "A"frame hoist cylinders
- Bronze tinted glass
- Footrest
- Electric engine throttle control grip
- Engine throttle pedal
- Loud speaker
- Foot-pin cylinders
- Crawler connect cylinder
- Rope guide roller on the boom back(for outer boom)

■ Attachment

- 3m,6m,9m insert boom (with pendant rope and guide roller)
- 10m basic jib and 6m insert jib(with pendant rope and guide roller)
- 1m auxiliary jib and auxiliary wire rope
- 100ton hook
- 50ton hook
- 30ton hook
- 12ton hook

OPTIONAL SPECIFICATIONS

■ Additional Device

- 3rd hoisting winch(no free fall)
- Main/Auxiliary hoisting winch with free fall(with mode selector)
- Reeving winch combined use tagline
- Tagline
- Drum rotation indication
- Monitor TV(for rear/drum view)
- Monitor TV(for hook/load)
- Mirror for drum
- Spark Arrestor
- Combustion type heater
- Fire extinguisher
- Operator cabin roof guard
- Planking (case for erect the boom)

■ Light And Instrument

- Yellow rotary light
- Airplane warning light
- Over load outside alarm light(red/yellow/green)
- Work light for drum
- Work light on boom
- Hand light
- Back light
- Level
- Anemometer

■ Step And Guard

- Cat walk(no handrail,for rear cab)
- Handrail for cat walk
- Wire-mesh boom walkway(for inner boom)
- Wire-mesh for boom walkway(for insert boom and outer boom)
- Safety guard on cab (handrail)
- Safety guard rope on main boom (stanchion rope)

■ Attachment

- 3m,6m,9m insert boom (with pendant rope and guide roller)
- 10m basic jib and 6m insert jib(with pendant rope and guide roller)
- 1m auxiliary jib and auxiliary wire rope
- 100ton hook
- 50ton hook
- 30ton hook
- 12ton hook

■ Name Plate

- Name plate(both side of base machine)
- Name plate(outer boom or both side of insert boom)

■ Other

- Large size tool box(with caster)
- Sling wire rope(for lifting machine,attachment)
- Lifting pad for crawler

Transport Dimensions and Weights

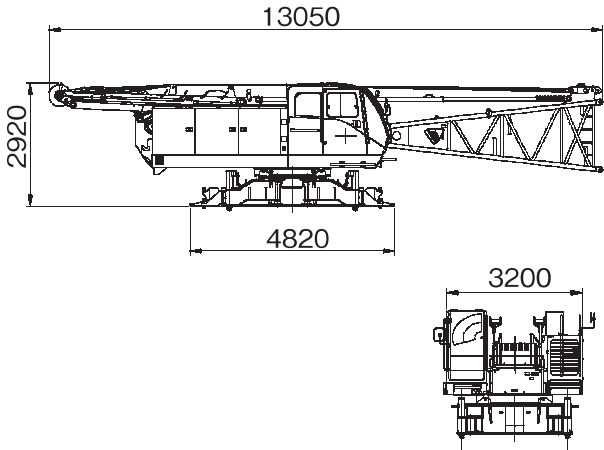
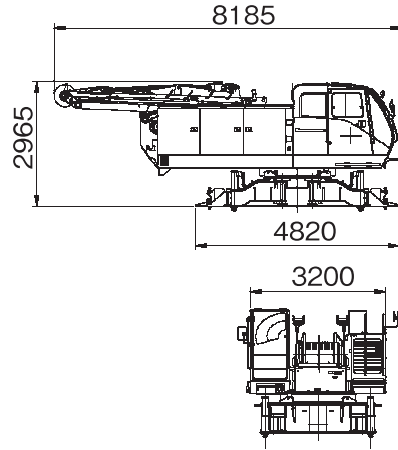
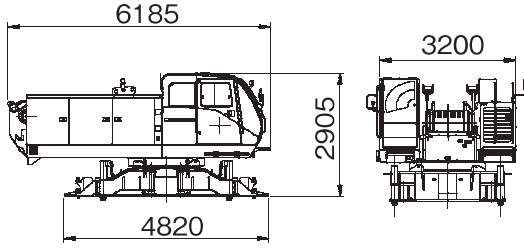
Name	Dimension (mm)	Q' ty	Weight (ton)
1st Disassembly Base Machine with: Main/Aux. Boom Hoist Drum Main Boom Hoist Wire A-frame Inner Boom		1	33.10
2nd Disassembly Base Machine with: Main/Aux. Boom Hoist Drum Main Boom Hoist Wire A-frame		1	31.40
3rd Disassembly Base Machine Only Main/Aux. Boom Hoist Drum Main Boom Hoist Wire		1	29.10



Transport Dimensions and Weights

Name	Dimension (mm)	Q' ty	Weight (ton)
Counterweight Ass'y (4 stage piling)			4stage (right) 3.00 4stage (left) 3.00 3stage 7.80 2stage 8.25 1stage (SA) 8.50 <hr/> Total 30.60
Crawler Ass'y		2	10.10×2
A-frame	H780×W1440×L4640 Excluding Hoist Cylinder & Boom Hoisting Wire	1	1.90
Pedestal (Jack up)	H210×W400×L400	4	0.04

Transport Dimensions and Weights

Crane/Tower				
Name	Dimension	Dimension (mm)	Q'ty	Weight (ton)
Inner Boom		H2010×W1720×L6210	1	1.72 (Crane) 2.90 (Tower)
Outer Boom (with pendant)		H1850×W1720×L7780	1	1.77
3m Insert Boom (with pendant)		H1820×W1720×L3130	1	0.50
6m Insert Boom (with pendant)		H1820×W1720×L6130	1	0.79
9m Insert Boom (with pendant)		H1820×W1720×L9130	1	1.10
Equalizer		H250×W1920×L760	1	0.41
Crane Jib				
Name	Dimension	Dimension (mm)	Q'ty	Weight (ton)
1m Aux. Jib	single 	H650×W430×L1530	1	0.24
	double 	H650×W700×L1530	1	0.47
Inner Jib (with strut)		H1230×W980×L5120	1	0.82
Outer Jib		H940×W850×L5400	1	0.31
6m Insert Jib		H950×W830×L6080	1	0.19

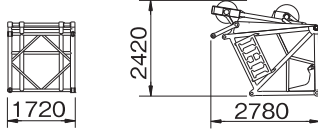
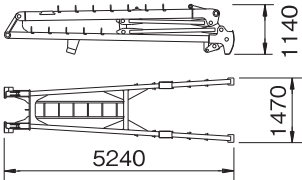
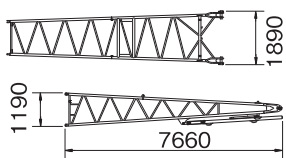
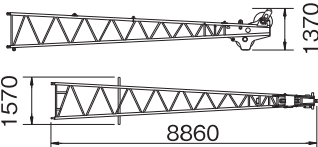
Transport Dimensions and Weights

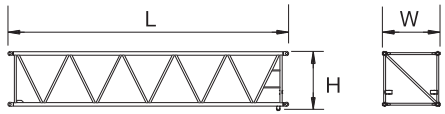
Tower Post/Jib				
Name	Dimension	Dimension (mm)	Q'ty	Weight (ton)
1m Insert Post (Sp)		H2010×W1720×L1130	1	0.28
9m Insert Post (Sp)		H1810×W1720×L9130	1	1.13
Tower Top		H2420×W1720×L2780	1	1.52
Strut		H1140×W1470×L5240	1	1.13
Middle Equalizer		H810×W810×L500	1	0.33
Inner Jib		H1190×W1890×L7660	1	0.75
Outer Jib		H1570×W1370×L8860	1	0.78
Jib Weight		Dφ 560×t100	2	0.40 ※with pin weight
3m Insert Jib		H1280×W1250×L3090	1	0.22
6m Insert Jib		H1280×W1250×L6090	1	0.35
9m Insert Jib		H1280×W1250×L9090	1	0.50

Transport Dimensions and Weights

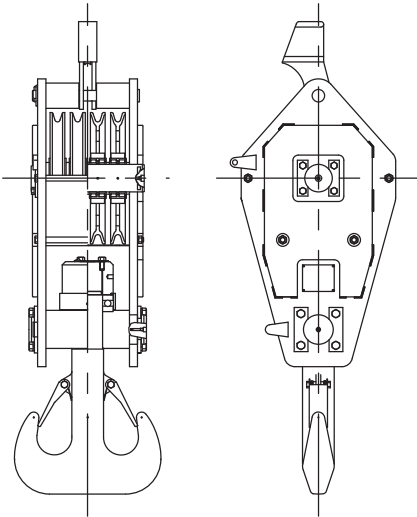
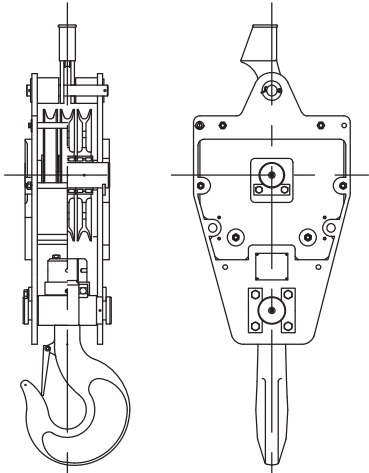
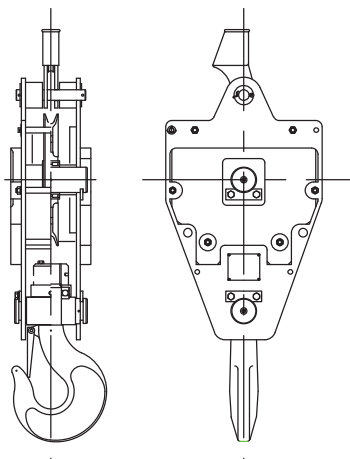
Hook (Crane & Tower)				
Name	Dimension	Dimension (mm)	Q'ty	Weight (ton)
100ton Hook		H480×W700×L2060	1	1.20
50ton Hook		H400×W740×L2080	1	0.95
30ton Hook (Hook for Tower, 15ton)		H380×W740×L1950	1	0.80

Transport Dimensions and Weights

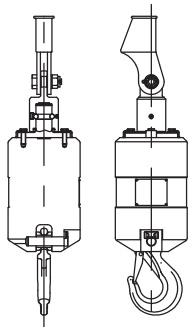
Hook (Crane & Tower)				
Name	Dimension	Dimension (mm)	Q'ty	Weight (ton)
12ton Hook		H340×W340×L1155	1	0.40

Lubricating Oil List

		Volume	Standard Oil Specs
Engine (QSL6.7)	Engine Oil	TOTAL : 17.0L	Showa Shell Sekyu Shell RimulaX 15W-40 CH-4/CF
	Coolant	TOTAL : 23.5L	(Anti-freezing 50% Concentration)
Hydraulic Oil Tank	Hydraulic Oil	TOTAL : 540L	Shell Tellus Oil 46
		Tank Level : 300L	

PAINTING

Finish painting will be in IHI standard painting color unless otherwise stated in the contract.

[Green] : Munsell No.10G6.5/8

[Gray] : Munsell No.N-3.0

REMARKS

(1) Should there be any difference between the descriptions in the Specifications Sheet and in the Catalogues, the description in the Specification Sheet shall supersede.

(2) Specifications are subject to change without notice due to improvement or modifications.

IHI **IHI Construction Machinery Limited**
3174 Showa-machi, Kanazawa-ku, Yokohama, Kanagawa 236-8611 Japan
Phone: +81(45)276-1252 Fax: 81(45)276-2583

<http://www.ihikenki.co.jp/english>

Specifications are subject to change without notice due to technical improvements or modifications
Distributed by



Printed in Japan
IK1300E1209LL20

Courtesy of Crane.Market