

THICCH300T

Fully Hydraulic Telescopic Crawler Crane

Lifting Capacity 30 Tonnes

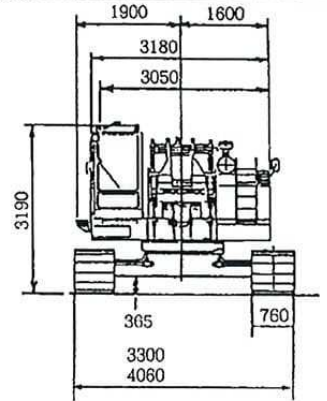
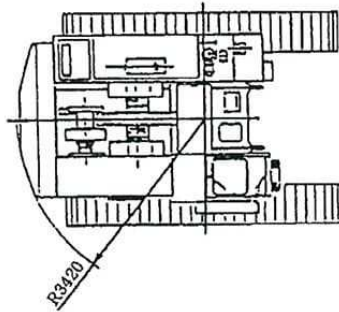
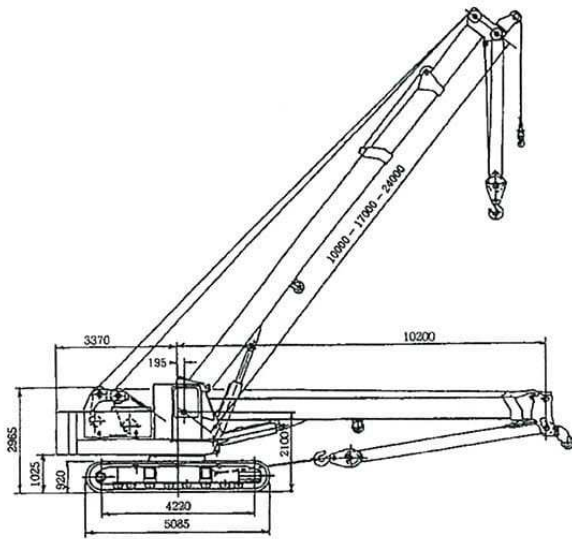

Main Boom Duties In Tonnes

EXTENDED CRAWLERS 4.06 MTR	BOOM LENGTH (MTR)			RETRACTED CRAWLERS 3.3 MTR	BOOM LENGTH (MTR)		
	10.0 MTR	17.0 MTR	24.0 MTR		10.0 MTR	17.0 MTR	24.0 MTR
WORKING RADIUS (MTR)				WORKING RADIUS (MTR)			
3.3	30.00			3.3	20.00		
3.5	27.00			3.5	18.70		
3.7	25.00			3.7	17.70		
4.0	22.00			4.0	16.20		
4.5	18.30	4.54=		4.5	14.00	14.00	
		18.00		5.0	12.40	12.40	
5.0	15.50	15.50		5.5	11.00	11.00	
5.5	13.45	13.45		6.0	9.70	9.70	9.70
6.0	11.80	11.80	5.90=	6.5	8.70	8.70	8.70
			12.00	7.0	7.80	7.80	7.80
6.5	10.35	10.35	10.35	7.5	7.10	7.10	7.10
7.0	9.25	9.25	9.25	8.0	6.50	6.50	6.50
7.5	8.30	8.30	8.30	8.5	5.80	5.80	5.80
8.0	7.55	7.55	7.55	9.0	5.40	5.40	5.40
8.5	6.90	6.90	6.90	10.0		4.60	4.60
9.0	6.35	6.35	6.35	11.0		3.90	3.90
10.0		5.45	5.45	12.0		3.40	3.40
11.0		4.70	4.70	13.0		2.90	2.90
12.0		4.20	4.20	14.0		2.50	2.50
13.0		3.75	3.75	15.0		2.20	2.20
14.0		3.35	3.35	16.0			1.90
15.0		3.05	3.05	17.0			1.60
16.0			2.75	18.0			1.50
17.0			2.50				
18.0			2.30				
19.0			2.10				
20.0			1.95				
21.0			1.80				
22.0			1.65				

Notes.

- The duty charts are based upon a crane working on firm and level ground, and refer to 360 deg rotation.
- The weight of the hook block and lifting tackle should be considered to be part of the load. 30 tonne cap hook block = 350 kgs : 5 tonne capacity hook block = 120 kgs.
- When using the main boom with fly jib attached 1500 kgs should be subtracted from the main boom duties throughout the range.
- When the 0.55 mtr aux jib (top sleeve) is used the SWL is the same as the main boom duty for any given radius but should not exceed 5 tonnes. When both main boom and auxillary hooks are fitted the weights of both hooks should be considered to be part of the load.
- With the 0.55 mtr auxillary jib in use the working radius of the aux jib point.

SPECIFICATIONS	
Max lift	30 tonnes at 3.3 mtr rad
Boom Length	10-24 mtr telescopic
Line speeds hoist and lower	40 mtr/min
Line speed third drum	55 mtr/min
Boom hoist speed	40 secs - 3 deg - 80 deg
Telescoping speed	60 secs 10-24 mtr
Swing speed	2.5 rpm
Gradeability	40%
Weight of basic crane	40.9 tonnes
Removeable Counterweight	7.9 tonnes
Av Bearing Pressure	0.57 Kgs/sq cm
Hydraulic PTO	Pressure 250 kg/sq cm Flow 260 Ltr/min

Fly Jib Duties In Tonnes Extended Crawlers

Offset	24 MTR BOOM WITH 6.7 MTR FLY JIB						24 MTR BOOM WITH 11.0 MTR FLY JIB					
	5 deg		17 deg		30 deg		5 deg		17 deg		30 deg	
Boom Angle	Radius	SWL	Radius	SWL	Radius	SWL	Radius	SWL	Radius	SWL	Radius	SWL
80 deg	7.3	3.00	8.6	2.50	9.9	2.00	8.5	2.00	10.7	1.60	12.6	1.00
78 deg	8.3	2.85	9.6	2.50	10.8	2.00	9.7	1.90	11.8	1.60	13.7	1.00
77 deg	8.8	2.80	10.1	2.50	11.3	2.00	10.3	1.85	12.4	1.60	14.2	1.00
75 deg	9.8	2.70	11.1	2.50	12.3	2.00	11.5	1.75	13.5	1.50	15.3	1.00
70 deg	12.3	2.35	13.5	2.20	14.6	2.00	14.3	1.55	16.8	1.30	17.9	0.90
65 deg	14.7	2.05	15.9	2.00	16.9	1.80	17.0	1.35	18.9	1.10	20.4	0.80
60 deg	17.0	1.75	18.1	1.75	19.0	1.60	19.7	1.15	21.4	0.90	22.7	0.70
55 deg	19.2	1.50	20.1	1.50	21.0	1.40	22.2	0.95	23.7	0.75		
50 deg			22.1	1.20	22.8	1.10						