

# HIAB 500 Capacity 50 tm



Product brochure



# A reliable well proven giant



## **The HIAB 500 is majestic**

The HIAB 500 is a 50 tonne-metre high capacity crane especially suitable to handle really heavy loads, safely and efficiently. The crane's advanced boom system is made of high tensile steel. Despite the crane's size, this keeps overall weight relatively low. What's more, the HIAB 500 has numerous features designed to reduce maintenance costs. Such as the internationally acclaimed JIC couplings which assures perfect connection and sealing in the hydraulic system. There are also extra large slide pads to ensure less wear on the boom extensions.

## **Increased productivity is there for you**

Up to six hydraulic extensions can be fitted, reaching more than 15 metres. If manual boom extensions are added, the HIAB 500 is provided with an outreach of over 23 metres. The HIAB Valve 50 is the main hydraulic valve and it is controlled from the control panel positioned at the base. The levers can also be placed at an optional high seat, giving you a first class view of the slewing area. Safety and productivity functions are managed by the MiniSPACE intelligence system.



### Front runners in boom design

A Hiab crane is built to withstand extreme loading under all kinds of circumstances, in all field conditions. Keeping the boom reliable, tough and sturdy under extreme loading has made Hiab a world leader in crane boom engineering. Taking a closer look at the crane, one can point out a number of features that our customers benefit from.

### Hexagonal boom profile

The hexagonal profile used on Hiab booms is a ground-breaking design introduced by Hiab many years ago. It is now standard throughout the market of loader cranes. Even the smallest of Hiab cranes benefit from this design.

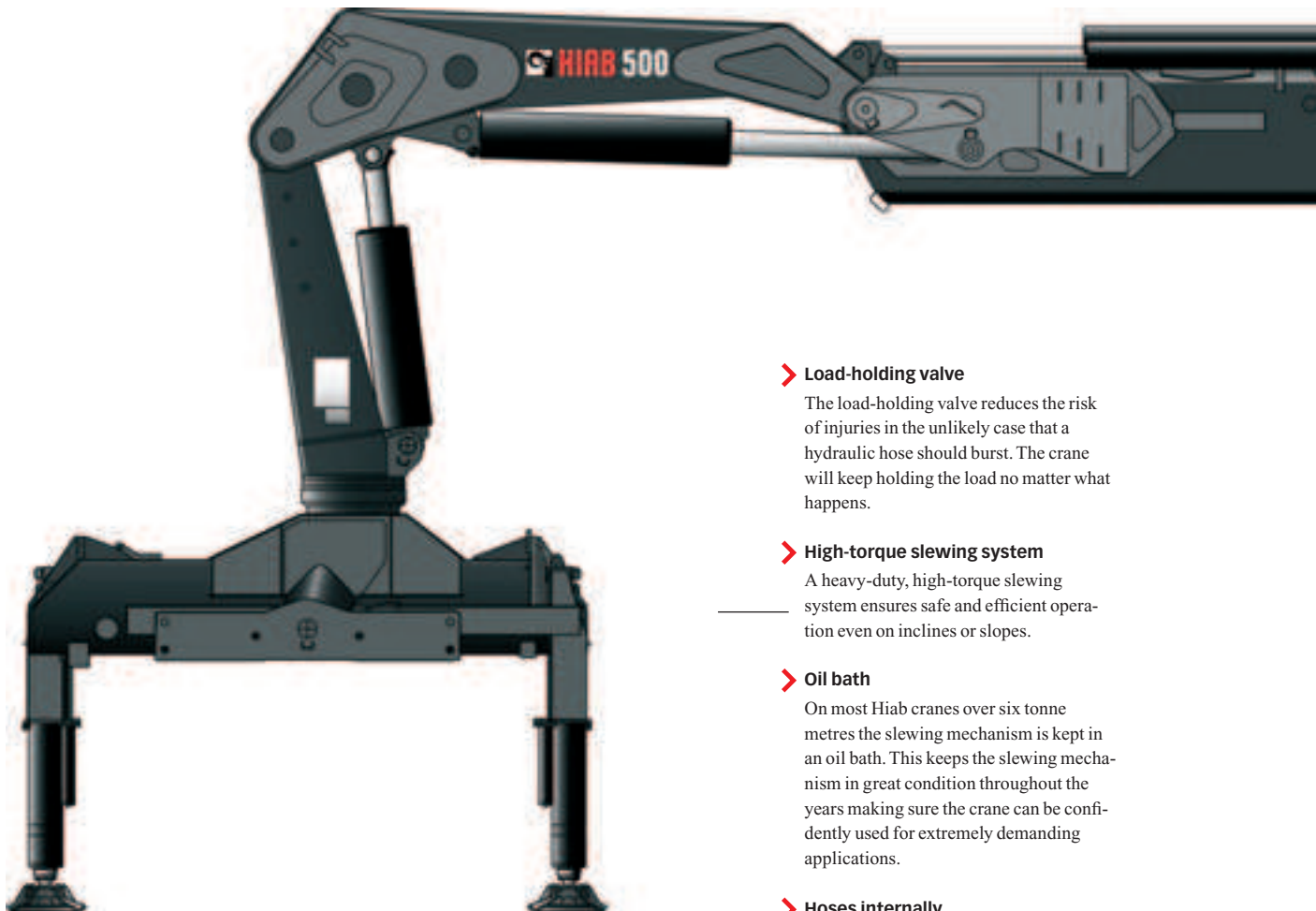

#### > Load-holding valve

The load-holding valve reduces the risk of injuries in the unlikely case that a hydraulic hose should burst. The crane will keep holding the load no matter what happens.

#### > High-torque slewing system

A heavy-duty, high-torque slewing system ensures safe and efficient operation even on inclines or slopes.

#### > Oil bath

On most Hiab cranes over six tonnes the slewing mechanism is kept in an oil bath. This keeps the slewing mechanism in great condition throughout the years making sure the crane can be confidently used for extremely demanding applications.

#### > Hoses internally

The hoses are run internally in the crane body and in the outrigger beam, where they are out of harm's way, thus reducing maintenance costs.

➤ **Hexagonal boom profile**

The hexagonal profile ensures the boom is always in perfect balance, due to its shape and big support surface. The profile also minimizes boom deflection. This reduces maintenance costs and increases efficiency.

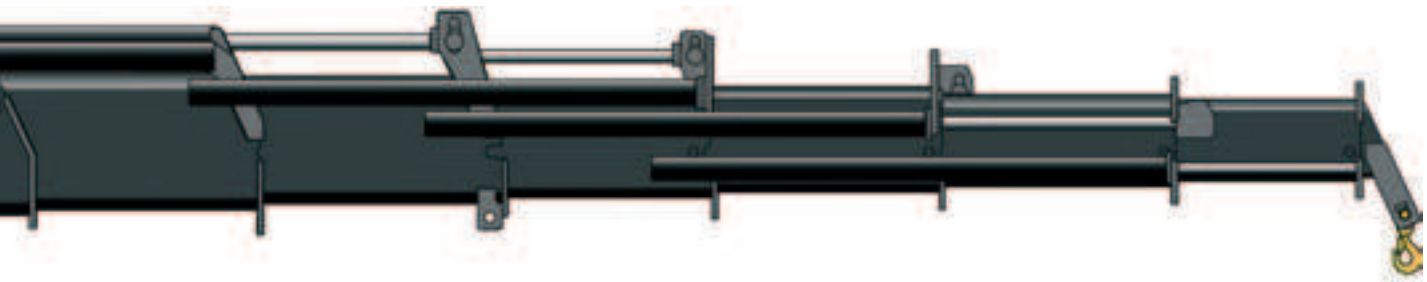

➤ **JIC couplings**

JIC couplings are standard on most Hiab cranes. They assure secure coupling easily, and are still very easy to disconnect for service.

➤ **Large slide pads**

Large slide pads reduce friction and wear keeping maintenance costs low. Also the boom system needs no greasing, and thus it is kept cleaner than our competitor's boom systems.

➤ **Attachable tools**

A wide range of attachable tools are available for your Hiab crane. These make sure you can carry out a lot of different tasks.

# HIAB 500 Capacity 50 tm

## > MiniSPACE intelligence system

The MiniSPACE system intelligently monitors and controls the electronic functions of your crane.

Safety is managed by an Over Load Protection (OLP) function. The OLP also enables you to work in front of the truck cabin, an area that is traditionally not possible to operate in. High boom warning also contributes to the increased safety that Hiab is so well known for.

Automatic Dumping of Oil (ADO) keeps the oil in top condition and thus reduces maintenance costs. This is done by leading the oil straight back into the tank when the crane is running idle.

Further more, the system handles functions primarily used by service personnel such as fault code indication and load cycle data.

## > Valve 50

The HIAB Valve 50 is well tested after many years of service on loader cranes. It is an open center valve and can handle a maximum pump flow of approximately 60 litres per minute. If the pump flow is too low the crane can't lift as much but on the other hand too much flow produces excess heat and vibration problems in the system.

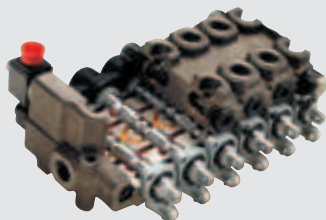

### > Valve 50

The HIAB Valve 50 is very reliable and provides good handling characteristics. This gives your crane a long life span, and low maintenance costs.

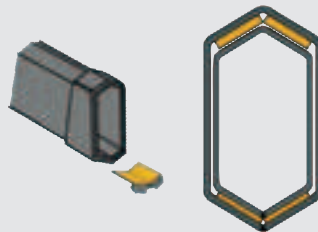

### > Large slide pads

Large slide pads reduce friction and wear keeping maintenance costs low. Also the boom system needs no greasing, and thus it is kept cleaner than our competitor's boom systems.

### > CombiDrive

With the HIAB CombiDrive you can position yourself at the best possible location when operating the crane. It features 12 proportional functions for controlling the crane, optional equipment and accessories, all with the same precision.



### > Cross controls

Cross controls incorporate the same control lever sequence on either side of the truck, minimizing the risk of human error.





