



**LOAD CHARTS  
RT640C**

**85% STABILITY  
ON OUTRIGGERS**

**75% STABILITY  
ON RUBBER**

---

**SERIAL NUMBER**

# NOTES FOR LIFTING CAPACITIES

## GENERAL:

1. Rated loads as shown on lift chart pertain to this machine as originally manufactured and equipped. Modifications to the machine or use of optional equipment other than that specified can result in a reduction of capacity.
2. Construction equipment can be hazardous if improperly operated or maintained. Operation and maintenance of this machine shall be in compliance with the information in the Operator's and Safety Handbook, Service Manual and Parts Manual supplied with this machine. If these manuals are missing, order replacements from the manufacturer through the distributor.
3. The operator and other personnel associated with machine shall fully acquaint themselves with the latest American National Safety Standards (ASME/ANSI) for cranes.

## SETUP:

1. The machine shall be level and on a firm supporting surface. Depending on the nature of the supporting surface, it may be necessary to have structural supports under the outrigger floats or tires to spread the load to a larger bearing surface.
2. For outrigger operation, outriggers shall be properly extended with tires raised free of crane weight before operating the boom or lifting loads.
3. When machine is equipped with center front stabilizer, the front stabilizer shall be set in accordance with instructions in Operator's & Safety Handbook.
4. When equipped with removable and/or extendible counterweight, the proper counterweight shall be installed and fully extended before and during operation.
5. If crane is approved by manufacturer for on-rubber lifting, tires shall be inflated to the recommended pressure before lifting on rubber.
6. With certain boom and hoist tackle combinations, maximum capacities may not be obtainable with standard cable lengths.
7. Unless approved by the crane manufacturer, do not travel with boom extension or jib erected. Refer to the Operator's and Safety Handbook for job-site travel information.

## OPERATION:

1. Rated loads at rated radius shall not be exceeded. Do not attempt to tip the machine to determine allowable loads. For clamshell or concrete bucket operation, weight of bucket and load must not exceed 80% of rated lifting capacities.
2. All rated loads have been tested to and meet minimum requirements of SAE J1063 - Cantilevered Boom Crane Structures - Method of Test, and do not exceed 85% of the tipping load on outriggers fully extended and 50% extended, and 75% of the tipping load on outriggers 0% extended (fully retracted) as determined by SAE J765 Crane Stability Test Code.
3. Rated loads include the weight of hookblock, slings and auxiliary lifting devices and their weights shall be subtracted from the listed rating to obtain the net load to be lifted. When more than the minimum required hoist reeving is used, the additional rope weight shall be considered part of the load to be lifted.
4. Load ratings are based on freely suspended loads. No attempt shall be made to move a load horizontally on the ground in any direction.
5. The maximum in-service wind speed is 20 m.p.h. (32 km/h). It is recommended when wind velocity is above 20 m.p.h. (32 km/h), rated loads and boom lengths shall be appropriately reduced. For machines not in-service, the main boom should be retracted and lowered with the swing brake set in wind velocities over 30 m.p.h. (48 km/h).
6. Rated loads are for lift crane service only.
7. Do not operate at a radius or boom length where capacities are not listed. At these positions, the machine may overturn without any load on the hook.
8. The maximum load which can be telescoped is not definable because of variations in loadings and crane maintenance, but it is safe to attempt retraction and extension of the boom within the limits of the capacity chart.
9. When the boom length or lift radius or both are between values listed, the smallest load shown at either the next larger radius or next longer or shorter boom length shall be used.
10. For safe operation, the user shall make due allowances for his particular job conditions, such as: soft or uneven ground, out of level conditions, high winds, side loads, pendulum action, jerking or sudden stopping of loads, experience of personnel, two machine (tandem) lifts, traveling with loads, electric wires, obstacles, hazardous conditions, etc. Side pull on boom or jib is extremely dangerous.
11. If machine is equipped with individually controlled powered boom sections, the boom sections must be extended equally at all times.
12. Never handle personnel with this machine unless the requirements of the applicable national, state, and local regulations and safety codes are met.
13. Keep load handling devices a minimum of 42 inches (107 cm) below boom head at all times.
14. The boom angle before loading should be greater than the loaded boom angle to account for deflection.
15. Capacities appearing above the bold line are based on structural strength and tipping should not be relied upon as a capacity limitation.
16. Capacities for the 34 ft. (10.4 m) boom length shall be lifted with boom fully retracted. If boom is not fully retracted, capacities shall not exceed those shown for the 40 ft. (12.2 m) boom length.
17. When operating the machine in the "On Outriggers 50% Extended (15' 9" spread)" mode, the outrigger beam pins must be engaged. When operating in the "On Outriggers 0% Extended (9' 3.5" spread)" mode, the outrigger beams must be fully retracted. Failure to follow these precautions could result in structural damage or loss of stability of the machine.
18. The maximum outrigger pad load is 64,800 pounds (29,393 kg).

## DEFINITIONS:

1. Operating Radius: Horizontal distance from a projection of the axis of rotation to the supporting surface before loading to the center of the vertical hoist line or tackle with load applied.
2. Loaded Boom Angle (Shown in Parenthesis on Main Boom Capacity Chart): is the angle between the boom base section and the horizontal, after lifting the rated load at the rated radius with the rated boom length.
3. Working Area: Areas measured in a circular arc about the center line of rotation as shown on the working area diagram.
4. Freely Suspended Load: Load hanging free with no direct external force applied except by the lift cable.
5. Side Load: Horizontal force applied to the lifted load either on the ground or in the air.

**RATED LIFTING CAPACITIES IN POUNDS**  
**34 FT. - 105 FT. BOOM**  
**ON OUTRIGGERS FULLY EXTENDED - 360°**

| Radius in Feet   | #0001                    |                  |                  |                  |                  |                  |                  |                  |                  |                   |
|--|--------------------------|------------------|------------------|------------------|------------------|------------------|------------------|------------------|------------------|-------------------|
|  | Main Boom Length in Feet |                  |                  |                  |                  |                  |                  |                  |                  |                   |
|  | 34                       | 40               | 50               | *58              | 60               | 70               | 80               | 90               | 100              | 105               |
| 10   | +80,000<br>(66)          | 72,100<br>(70)   | 60,000<br>(74.5) | 43,650<br>(76.5) | 31,000<br>(77)   |                  |                  |                  |                  |                   |
| 12   | 73,300<br>(62)           | 72,100<br>(67)   | 57,000<br>(72)   | 43,650<br>(74.5) | 31,000<br>(75)   | 31,000<br>(78)   |                  |                  |                  |                   |
| 15   | 62,700<br>(55.5)         | 62,400<br>(62)   | 54,600<br>(68.5) | 43,650<br>(71.5) | 31,000<br>(72.5) | 31,000<br>(75.5) |                  |                  |                  |                   |
| 20   | 47,300<br>(43.5)         | 47,000<br>(52.5) | 45,000<br>(61.5) | 38,250<br>(66)   | 31,000<br>(67.5) | 31,000<br>(72)   | 30,700<br>(75)   | 27,000<br>(77)   |                  |                   |
| 25   | 36,000<br>(26.5)         | 35,800<br>(42)   | 35,400<br>(54.5) | 33,100<br>(60.5) | 31,000<br>(62.5) | 30,350<br>(67.5) | 26,400<br>(71)   | 23,250<br>(74)   | 19,000<br>(75.5) | @17,500<br>(76.5) |
| 30   |                          | 29,000<br>(27.5) | 28,500<br>(46.5) | 28,200<br>(54)   | 27,400<br>(56.5) | 25,150<br>(62.5) | 23,000<br>(67)   | 20,300<br>(70.5) | 18,500<br>(72.5) | 17,500<br>(74)    |
| 35   |                          |                  | 23,500<br>(37.5) | 23,200<br>(47.5) | 23,200<br>(50)   | 22,650<br>(57.5) | 20,300<br>(63)   | 18,500<br>(67)   | 17,000<br>(69.5) | 15,700<br>(71)    |
| 40   |                          |                  | 18,350<br>(24.5) | 18,100<br>(39.5) | 18,250<br>(43)   | 18,300<br>(52.5) | 18,100<br>(58.5) | 16,800<br>(63)   | 14,200<br>(66.5) | 13,700<br>(68)    |
| 45   | See Note 16              |                  |                  | 14,300<br>(30)   | 14,450<br>(34.5) | 14,800<br>(46.5) | 14,900<br>(54)   | 14,000<br>(59)   | 13,000<br>(63)   | 12,200<br>(64.5)  |
| 50   |                          |                  |                  | 11,500<br>(13.5) | 11,650<br>(23)   | 12,100<br>(40)   | 12,200<br>(49)   | 12,100<br>(55)   | 11,900<br>(59.5) | 10,700<br>(61.5)  |
| 55   |                          |                  |                  |                  |                  | 10,200<br>(32)   | 10,850<br>(43.5) | 11,250<br>(51)   | 11,650<br>(56)   | 10,200<br>(58)    |
| 60   |                          |                  |                  |                  |                  | 8,460<br>(21.5)  | 9,150<br>(37.5)  | 9,530<br>(46)    | 9,900<br>(52)    | 10,050<br>(54.5)  |
| 65   |                          |                  |                  |                  |                  |                  | 7,740<br>(30.5)  | 8,100<br>(41)    | 8,470<br>(48)    | 8,650<br>(51)     |
| 70   |                          |                  |                  |                  |                  |                  | 6,560<br>(20.5)  | 6,920<br>(35)    | 7,280<br>(43.5)  | 7,460<br>(47)     |
| 75   |                          |                  |                  |                  |                  |                  |                  | 5,920<br>(28.5)  | 6,270<br>(38.5)  | 6,450<br>(42.5)   |
| 80   |                          |                  |                  |                  |                  |                  |                  | 5,070<br>(18.5)  | 5,410<br>(33.5)  | 5,590<br>(38)     |
| 85   |                          |                  |                  |                  |                  |                  |                  |                  | 4,670<br>(26.5)  | 4,840<br>(32.5)   |
| 90   |                          |                  |                  |                  |                  |                  |                  |                  | 4,020<br>(18)    | 4,190<br>(26)     |
| 95   |                          |                  |                  |                  |                  |                  |                  |                  |                  | 3,620<br>(17.5)   |
| Minimum boom angle (deg.) for indicated length           |                          |                  |                  |                  |                  |                  |                  |                  |                  | 0                 |
| Maximum boom length (ft.) at 0 deg. boom angle (no load) |                          |                  |                  |                  |                  |                  |                  |                  |                  | 105               |

Note: ( ) Boom angles are in degrees.

#LMI operating code. Refer to LMI manual for instructions.

| Boom Angle | Lifting Capacities at Zero Degree Boom Angle On Outriggers Fully Extended - 360° |                |               |                 |               |               |               |               |               |               |
|------------|--|----------------|---------------|-----------------|---------------|---------------|---------------|---------------|---------------|---------------|
|            | 34   | 40             | 50            | *58             | 60            | 70            | 80            | 90            | 100           | 105           |
| 0°         | 16,350<br>(27.1)   | 12,700<br>(33) | 8,390<br>(43) | 6,030<br>(50.8) | 5,710<br>(53) | 4,380<br>(63) | 3,370<br>(73) | 2,590<br>(83) | 1,960<br>(93) | 1,700<br>(98) |

Note: ( ) Reference radii in feet.

A6-829-100535

\*58 ft. boom length is with inner-mid extended and outer-mid & fly retracted.

@Capacity also applicable at maximum boom angle.

+ 7 parts of line required to lift this capacity (using auxiliary boom nose). Refer to Operator's & Safety Handbook for reeving diagram.

**ON RUBBER CAPACITIES WITH 23.5R25 TIRES  
STATIONARY CAPACITIES - 360°**

| Radius in Feet | #9005                    |                 |                  |                  |                  |                 |                 |                 |                 |
|----------------|--------------------------|-----------------|------------------|------------------|------------------|-----------------|-----------------|-----------------|-----------------|
|                | Main Boom Length in Feet |                 |                  |                  |                  |                 |                 |                 |                 |
|                | 34                       | 40              | 50               | *58              | 60               | 70              | 80              | 90              | 100             |
| 10             | 31,700<br>(66)           | 31,200<br>(70)  |                  |                  |                  |                 |                 |                 |                 |
| 12             | 26,900<br>(62)           | 26,250<br>(67)  | 25,200<br>(72)   | 24,400<br>(74.5) | 24,400<br>(75.5) |                 |                 |                 |                 |
| 15             | 19,650<br>(56)           | 19,400<br>(62)  | 19,050<br>(68.5) | 18,700<br>(71.5) | 18,700<br>(72.5) |                 |                 |                 |                 |
| 20             | 11,850<br>(44)           | 11,600<br>(53)  | 11,250<br>(61.5) | 11,100<br>(66)   | 11,150<br>(67)   | 11,950<br>(71)  |                 |                 |                 |
| 25             | 7,770<br>(27)            | 7,560<br>(42.5) | 7,210<br>(54.5)  | 6,820<br>(60.5)  | 7,090<br>(61.5)  | 7,780<br>(66.5) | 8,480<br>(70)   | 8,810<br>(72.5) |                 |
| 30             |                          | 4,980<br>(28)   | 4,400<br>(46.5)  | 4,110<br>(54)    | 4,420<br>(56)    | 5,210<br>(61.5) | 5,820<br>(66)   | 6,170<br>(69)   | 6,170<br>(71.5) |
| 35             |                          |                 | 2,580<br>(37.5)  | 2,160<br>(47.5)  | 2,360<br>(49.5)  | 3,420<br>(57)   | 3,690<br>(62)   | 4,230<br>(65.5) | 4,230<br>(68.5) |
| 40             |                          |                 |                  |                  |                  | 1,900<br>(51.5) | 2,100<br>(57.5) | 2,760<br>(62)   | 2,760<br>(65.5) |
| 45             |                          |                 |                  |                  |                  |                 |                 | 1,600<br>(58)   | 1,600<br>(62)   |

**STATIONARY CAPACITIES - DEFINED ARC OVER FRONT (See note 3)**

| Radius in Feet | #9005                    |                  |                  |                  |                  |                  |                 |                  |                 |
|----------------|--------------------------|------------------|------------------|------------------|------------------|------------------|-----------------|------------------|-----------------|
|                | Main Boom Length in Feet |                  |                  |                  |                  |                  |                 |                  |                 |
|                | 34                       | 40               | 50               | *58              | 60               | 70               | 80              | 90               | 100             |
| 10             | 36,850<br>(66)           | 34,600<br>(70)   |                  |                  |                  |                  |                 |                  |                 |
| 12             | 32,550<br>(62)           | 30,650<br>(67)   | 27,450<br>(72)   | 24,400<br>(74.5) | 24,400<br>(75.5) |                  |                 |                  |                 |
| 15             | 27,400<br>(56)           | 25,900<br>(62)   | 21,100<br>(68.5) | 21,100<br>(71.5) | 21,100<br>(72.5) |                  |                 |                  |                 |
| 20             | 21,100<br>(44)           | 20,050<br>(53)   | 18,300<br>(61.5) | 16,900<br>(66)   | 16,900<br>(67)   | 16,400<br>(71)   | 14,450<br>(74)  |                  |                 |
| 25             | 15,900<br>(27)           | 15,600<br>(42.5) | 14,650<br>(54.5) | 13,650<br>(60.5) | 13,650<br>(61.5) | 13,650<br>(66.5) | 13,000<br>(70)  | 11,250<br>(72.5) |                 |
| 30             |                          | 11,150<br>(28)   | 9,070<br>(46.5)  | 10,250<br>(54)   | 10,400<br>(56)   | 11,200<br>(61.5) | 11,200<br>(66)  | 10,150<br>(69)   | 8,090<br>(71.5) |
| 35             |                          |                  | 7,760<br>(37.5)  | 7,440<br>(47.5)  | 7,590<br>(49.5)  | 8,260<br>(57)    | 8,920<br>(62)   | 8,920<br>(65.5)  | 7,370<br>(68.5) |
| 40             |                          |                  | 5,720<br>(24.5)  | 5,450<br>(39.5)  | 5,580<br>(42.5)  | 6,190<br>(51.5)  | 6,800<br>(57.5) | 7,140<br>(62)    | 6,660<br>(65.5) |
| 45             |                          |                  |                  | 3,970<br>(30)    | 4,100<br>(34)    | 4,660<br>(45.5)  | 5,220<br>(53)   | 5,530<br>(58)    | 5,840<br>(62)   |
| 50             |                          |                  |                  | 2,840<br>(13.5)  | 2,950<br>(22)    | 3,480<br>(39)    | 3,990<br>(48)   | 4,300<br>(54)    | 4,600<br>(58.5) |
| 55             |                          |                  |                  |                  |                  | 2,550<br>(31.5)  | 3,010<br>(42.5) | 3,320<br>(50)    | 3,620<br>(55)   |
| 60             |                          |                  |                  |                  |                  | 1,800<br>(20.5)  | 2,220<br>(36.5) | 2,520<br>(45.5)  | 2,820<br>(51.5) |
| 65             |                          |                  |                  |                  |                  |                  | 1,550<br>(29.5) | 1,860<br>(40.5)  | 2,150<br>(47.5) |
| 70             |                          |                  |                  |                  |                  |                  | 1,000<br>(19.5) | 1,300<br>(34.5)  | 1,580<br>(43)   |
| 75             |                          |                  |                  |                  |                  |                  |                 |                  | 1,100<br>(38.5) |

A6-829-011622 & -011623

## ON RUBBER CAPACITIES WITH 23.5R25 TIRES (CONT'D.)

### PICK & CARRY CAPACITIES (UP TO 2.5 MPH) - BOOM CENTERED OVER FRONT (SEE NOTE 7)

| Radius<br>in<br>Feet | #9006                    |                  |                  |                  |                  |                  |                 |                 |                 |
|----------------------|--------------------------|------------------|------------------|------------------|------------------|------------------|-----------------|-----------------|-----------------|
|                      | Main Boom Length in Feet |                  |                  |                  |                  |                  |                 |                 |                 |
|                      | 34                       | 40               | 50               | *58              | 60               | 70               | 80              | 90              | 100             |
| 10                   | 38,150<br>(66)           | 38,150<br>(70)   |                  |                  |                  |                  |                 |                 |                 |
| 12                   | 33,350<br>(62)           | 33,350<br>(67)   |                  |                  |                  |                  |                 |                 |                 |
| 15                   | 27,800<br>(56)           | 27,700<br>(62)   |                  |                  |                  |                  |                 |                 |                 |
| 20                   | 21,450<br>(44)           | 21,250<br>(53)   | 20,900<br>(61.5) | 20,650<br>(66)   | 20,850<br>(67)   |                  |                 |                 |                 |
| 25                   | 15,900<br>(27)           | 15,600<br>(42.5) | 15,050<br>(54.5) | 14,600<br>(60.5) | 14,800<br>(61.5) |                  |                 |                 |                 |
| 30                   |                          | 11,150<br>(28)   | 9,070<br>(46.5)  | 10,250<br>(54)   | 10,400<br>(56)   | 11,200<br>(61.5) | 11,950<br>(66)  |                 |                 |
| 35                   |                          |                  | 7,760<br>(37.5)  | 7,440<br>(47.5)  | 7,590<br>(49.5)  | 8,260<br>(57)    | 8,920<br>(62)   | 9,300<br>(65.5) | 9,620<br>(68.5) |
| 40                   |                          |                  | 5,720<br>(24.5)  | 5,450<br>(39.5)  | 5,580<br>(42.5)  | 6,190<br>(51.5)  | 6,800<br>(57.5) | 7,140<br>(62)   | 7,450<br>(65.5) |
| 45                   |                          |                  |                  | 3,970<br>(30)    | 4,100<br>(34)    | 4,660<br>(45.5)  | 5,220<br>(53)   | 5,530<br>(58)   | 5,840<br>(62)   |
| 50                   |                          |                  |                  | 2,840<br>(13.5)  | 2,510<br>(22)    | 3,480<br>(39)    | 3,990<br>(48)   | 4,300<br>(54)   | 4,600<br>(58.5) |
| 55                   |                          |                  |                  |                  |                  | 2,550<br>(31.5)  | 3,010<br>(42.5) | 3,320<br>(50)   | 3,620<br>(55)   |
| 60                   |                          |                  |                  |                  |                  | 1,800<br>(20.5)  | 2,220<br>(36.5) | 2,520<br>(45.5) | 2,820<br>(51.5) |
| 65                   |                          |                  |                  |                  |                  |                  | 1,550<br>(29.5) | 1,860<br>(40.5) | 2,150<br>(47.5) |
| 70                   |                          |                  |                  |                  |                  |                  | 1,000<br>(19.5) | 1,300<br>(34.5) | 1,580<br>(43)   |
| 75                   |                          |                  |                  |                  |                  |                  |                 |                 | 1,100<br>(38.5) |

Note: ( ) Boom angles are in degrees.

A6-829-011624

#LMI operating code. Refer to LMI manual for operating instructions.

\*58 ft. boom length is with inner-mid extended and outer-mid & fly retracted.

|                       | No Load Stability Data                      | Main Boom<br>100 ft. |
|-----------------------|---|----------------------|
| Front<br>(No Load)    | Min. boom angle (deg.) for indicated length | 31                   |
|                       | Max. boom length (ft.) at 0 deg. boom angle | 80                   |
| 360 Deg.<br>(No Load) | Min. boom angle (deg.) for indicated length | 53                   |
|                       | Max. boom length (ft.) at 0 deg. boom angle | 50                   |

1. Capacities do not exceed 75% of tipping loads as determined by test in accordance with SAE J765 OCT80.
2. Capacities are applicable to machines equipped with Michelin 23.5R25\* XHA or Michelin 23.5R25 XADN (185B) tires at 75 psi cold inflation pressure and Goodyear 23.5R25\*\* GP2B tires at 80 psi cold inflation pressure.
3. Defined Arc - Over front includes 6° on either side of longitudinal centerline of machine.
4. Capacities appearing above the bold line are based on structural strength and tipping should not be relied upon as a capacity limitation.
5. Capacities are applicable only with machine on firm level surface.
6. On rubber lifting with boom extension not permitted.
7. For pick & carry operation, boom must be centered over front of machine, mechanical swing lock engaged and load restrained from swinging. When handling loads in the structural range with capacities close to maximum ratings, travel should be reduced to creep speeds.
8. Axle lockouts must be functioning when lifting on rubber.
9. All lifting depends on proper tire inflation, capacity and condition. Capacities must be reduced for lower tire inflation pressures. See lifting capacity chart for tire used. Damaged tires are hazardous to safe operation of crane.
10. Creep - not over 200 ft. of movement in any 30 minute period and not exceeding 1 mph.

# ZERO DEGREE BOOM ANGLE CHARTS

## ON RUBBER

### 23.5R25 TIRES (GOODYEAR & MICHELIN)

Stationary Capacity Defined Arc Over Front (See Note 3)

| Boom Angle | Main Boom Length in Feet |               |               |                 |               |               |
|------------|--------------------------|---------------|---------------|-----------------|---------------|---------------|
|            | 34                       | 40            | 50            | *58             | 60            | 70            |
| 0°         | 13,850<br>(27.1)         | 9,240<br>(33) | 4,760<br>(43) | 2,690<br>(50.8) | 2,410<br>(53) | 1,410<br>(63) |

Stationary Capacity 360° Arc

| Boom Angle | Main Boom Length in Feet |               |  |
|------------|--------------------------|---------------|--|
|            | 34                       | 40            |  |
| 0°         | 6,560<br>(27.1)          | 3,840<br>(33) |  |

Pick & Carry Capacities Up to 2.5 MPH  
Boom Centered Over Front (See Note 7)

| Boom Angle | Main Boom Length in Feet |               |               |                 |               |               |
|------------|--------------------------|---------------|---------------|-----------------|---------------|---------------|
|            | 34                       | 40            | 50            | *58             | 60            | 70            |
| 0°         | 13,850<br>(27.1)         | 9,170<br>(33) | 4,760<br>(43) | 2,690<br>(50.8) | 2,410<br>(53) | 1,410<br>(63) |

A6-829-011625

Note: ( ) Reference radii in feet.

\*58 ft. boom length is with inner-mid extended and outer-mid & fly retracted.

**29 FT. BOOM EXTENSION**  
**ON O/R FULLY EXTENDED - 360°**

| Radius<br>in<br>Feet | 29 ft. LENGTH   |                 |
|----------------------|-----------------|-----------------|
|                      | #0051           | #0053           |
|                      | 0° OFFSET       | 30° OFFSET      |
| 30                   | 9,360<br>(77.5) |                 |
| 35                   | 8,960<br>(75.5) |                 |
| 40                   | 8,610<br>(73)   | *5,360<br>(78)  |
| 45                   | 7,860<br>(71)   | 5,160<br>(75.5) |
| 50                   | 7,210<br>(68.5) | 4,960<br>(73.5) |
| 55                   | 6,610<br>(66)   | 4,760<br>(71)   |
| 60                   | 5,960<br>(64)   | 4,710<br>(68.5) |
| 65                   | 5,360<br>(61.5) | 4,660<br>(66)   |
| 70                   | 4,810<br>(58.5) | 4,610<br>(63.5) |
| 75                   | 4,360<br>(56)   | 4,560<br>(60.5) |
| 80                   | 3,910<br>(53.5) | 4,160<br>(58)   |
| 85                   | 3,510<br>(50.5) | 3,660<br>(55)   |
| 90                   | 3,160<br>(47.5) | 3,260<br>(52)   |
| 95                   | 2,860<br>(44.5) | 2,860<br>(48.5) |
| 100                  | 2,430<br>(41)   | 2,430<br>(45)   |
| 105                  | 2,020<br>(37.5) | 2,020<br>(41.5) |
| 110                  | 1,670<br>(33)   | 1,670<br>(37)   |

A6-829-011544

Note: ( ) Boom angles are in degrees.

\*This capacity is based upon maximum boom angle.

#LMI operating code. Refer to LMI manual for instructions.

1. All capacities above the bold line are based on structural strength of boom extension.
2. 29 ft. boom extension length may be used for single line lifting service only.
3. Radii listed are for a fully extended boom with the boom extension erected. For main boom lengths less than fully extended, the rated loads are determined by boom angle. Use only the column which corresponds to the boom extension length and offset for which the machine is configured. For boom angles not shown, use the rating of the next lower boom angle. **WARNING:** Operation of this machine with heavier loads than the capacities listed is strictly prohibited. Machine tipping with boom extension occurs rapidly and without advance warning.

RT640C - S/N

4. Boom angle is the angle above or below horizontal of the longitudinal axis of the boom base section after lifting rated load.
5. Capacities listed are with outriggers fully extended and vertical jacks set only.
6. **29 FT. OFFSETTABLE BOOM EXTENSION WARNING:** For main boom length greater than 100 ft. with 29 ft. boom extension in working position, the boom angle must not be less than 30° since loss of stability will occur causing a tipping condition. The boom angle is not restricted for main boom length equal to or less than 100 ft. This warning also applies for boom extension erection purposes.

**LINE PULLS AND REEVING INFORMATION**

| HOISTS                  | CABLE SPECS.   | PERMISSIBLE<br>LINE PULLS |
|-------------------------|--|---------------------------|
| Main & Aux.<br>Model 30 | 3/4" (19 mm) 18x19 Class or 35x7<br>Rotation Resistant<br>Min. Breaking Str. 64,600 lbs. | 12,920 lbs.               |
| Main & Aux.<br>Model 30 | 3/4" (19 mm) 6x37 Class<br>EIPS IWRC Special Flexible<br>Min. Breaking Str. 58,800 lbs.  | 12,920 lbs.               |

**WEIGHT REDUCTIONS FOR  
LOAD HANDLING DEVICES**

| 29 FT. BOOM EXTENSION |            |
|-----------------------|------------|
| *Stowed -             | 421 lbs.   |
| *Erected -            | 2,875 lbs. |

| 29 FT. - 51 FT. BOOM EXTENSION |            |
|--------------------------------|------------|
| *Stowed -                      | 641 lbs.   |
| *Erected (Retracted) -         | 4,378 lbs. |
| *Erected (Extended) -          | 6,628 lbs. |

\*Reduction of main boom capacities

|                                       |           |
|---------------------------------------|-----------|
| AUXILIARY BOOM HEAD                   | 143 lbs.  |
| <b>HOOKBLOCKS and HEADACHE BALLS:</b> |           |
| 40 Ton, 3 Sheave                      | 829 lbs.+ |
| 40 Ton, 3 Sheave<br>(w/cheekplates)   | 977 lbs.+ |
| 15 Ton, 1 Sheave                      | 380 lbs.+ |
| 10 Ton Headache Ball                  | 560 lbs.+ |

+Refer to rating plate for actual weight.

When lifting over swingaway and/or jib combinations, deduct total weight of all load handling devices reeved over main boom nose directly from swingaway or jib capacity.

**NOTE:** All load handling devices and boom attachments are considered part of the load and suitable allowances **MUST BE MADE** for their combined weights. Weights are for Grove furnished equipment.

## 29 FT. - 51 FT. TELE. EXTENSION

### ON OUTRIGGERS FULLY EXTENDED - 360°

| Radius<br>in<br>Feet | 29 ft. LENGTH   |                 | 51 ft. LENGTH   |                 |
|----------------------|-----------------|-----------------|-----------------|-----------------|
|                      | #0021           | #0023           | #0041           | #0043           |
|                      | 0°<br>OFFSET    | 30°<br>OFFSET   | 0°<br>OFFSET    | 30°<br>OFFSET   |
| 30                   | 9,000<br>(77.5) |                 |                 |                 |
| 35                   | 8,600<br>(75.5) |                 | *5,065<br>(78)  |                 |
| 40                   | 8,250<br>(73)   | *5,000<br>(78)  | 4,900<br>(76.5) |                 |
| 45                   | 7,500<br>(71)   | 4,800<br>(75.5) | 4,700<br>(74.5) |                 |
| 50                   | 6,850<br>(68.5) | 4,600<br>(73.5) | 4,400<br>(73)   |                 |
| 55                   | 6,250<br>(66)   | 4,400<br>(71)   | 4,000<br>(71)   | *2,800<br>(78)  |
| 60                   | 5,600<br>(64)   | 4,350<br>(68.5) | 3,800<br>(69)   | 2,700<br>(77)   |
| 65                   | 5,000<br>(61.5) | 4,300<br>(66)   | 3,700<br>(67)   | 2,600<br>(75)   |
| 70                   | 4,450<br>(58.5) | 4,250<br>(63.5) | 3,500<br>(65)   | 2,500<br>(72.5) |
| 75                   | 4,000<br>(56)   | 4,200<br>(60.5) | 3,400<br>(62.5) | 2,400<br>(70.5) |
| 80                   | 3,550<br>(53.5) | 3,800<br>(58)   | 3,300<br>(60.5) | 2,350<br>(68)   |
| 85                   | 3,150<br>(50.5) | 3,300<br>(55)   | 3,100<br>(58.5) | 2,300<br>(66)   |
| 90                   | 2,800<br>(47.5) | 2,860<br>(52)   | 2,900<br>(56)   | 2,250<br>(63.5) |
| 95                   | 2,360<br>(44.5) | 2,360<br>(48.5) | 2,700<br>(54)   | 2,200<br>(61)   |
| 100                  | 1,910<br>(41)   | 1,910<br>(45)   | 2,350<br>(51.5) | 2,150<br>(58.5) |
| 105                  | 1,510<br>(37.5) | 1,510<br>(41.5) | 2,050<br>(49)   | 2,150<br>(55.5) |
| 110                  | 1,150<br>(33)   | 1,150<br>(37)   | 1,900<br>(46)   | 2,040<br>(52.5) |
| 115                  |                 |                 | 1,680<br>(43.5) | 1,680<br>(49.5) |
| 120                  |                 |                 | 1,360<br>(40.5) | 1,360<br>(46.5) |
| 125                  |                 |                 | 1,060<br>(37)   | 1,060<br>(43)   |

A6-829-011361B

NOTE: ( ) Boom angles are in degrees.

\*This capacity is based upon maximum boom angle.

#LMI operating code. Refer to LMI manual for instructions.

RT640C - S/N

1. All capacities above the bold line are based on structural strength of boom extension.
2. 29 ft. and 51 ft. boom extension lengths may be used for single line lifting service only.
3. Radii listed are for a fully extended boom with the boom extension erected. For main boom lengths less than fully extended, the rated loads are determined by boom angle. Use only the column which corresponds to the boom extension length and offset for which the machine is configured. For boom angles not shown, use the rating of the next lower boom angle.

**WARNING:** Operation of this machine with heavier loads than the capacities listed is strictly prohibited. Machine tipping with boom extension occurs rapidly and without advance warning.

4. Boom angle is the angle above or below horizontal of the longitudinal axis of the boom base section after lifting rated load.
5. Capacities listed are with outriggers fully extended and vertical jacks set only.
6. 29 FT. TELE. OFFSETTABLE BOOM EXTENSION WARNING: For main boom length greater than 100 ft. with 29 ft. tele. boom extension in working position, the boom angle must not be less than 30° since loss of stability will occur causing a tipping condition. The boom angle is not restricted for main boom length equal to or less than 100 ft. This warning also applies for boom extension erection purposes.

51 FT. TELE. OFFSETTABLE BOOM EXTENSION WARNING: For main boom length greater than 90 ft. with 51 ft. tele. boom extension in working position, the boom angle must not be less than 33.5° since loss of stability will occur causing a tipping condition. The boom angle is not restricted for main boom length equal to or less than 90 ft. This warning also applies for boom extension erection purposes.



WORKING RANGE DIAGRAM  
(BOOM DEFLECTION NOT SHOWN) D6-829-011327

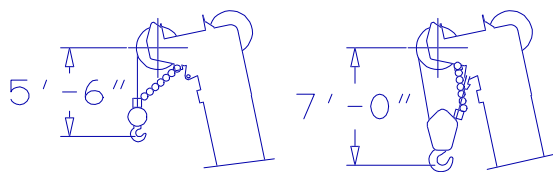
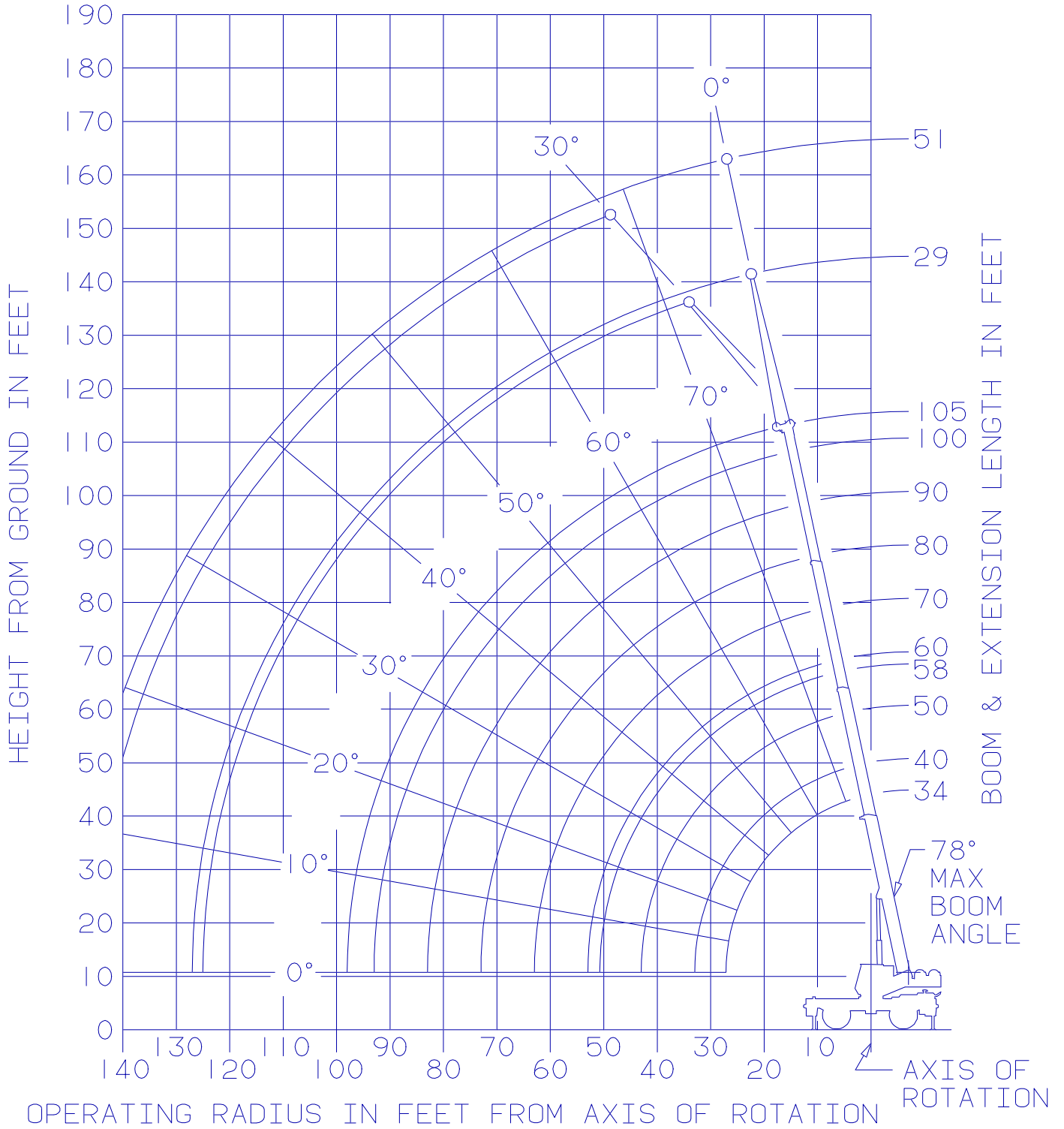

DIMENSIONS ARE FOR LARGEST GROVE FURNISHED HOOK BLOCK AND HEADACHE BALL, WITH ANTI-TWO BLOCK ACTIVATED.

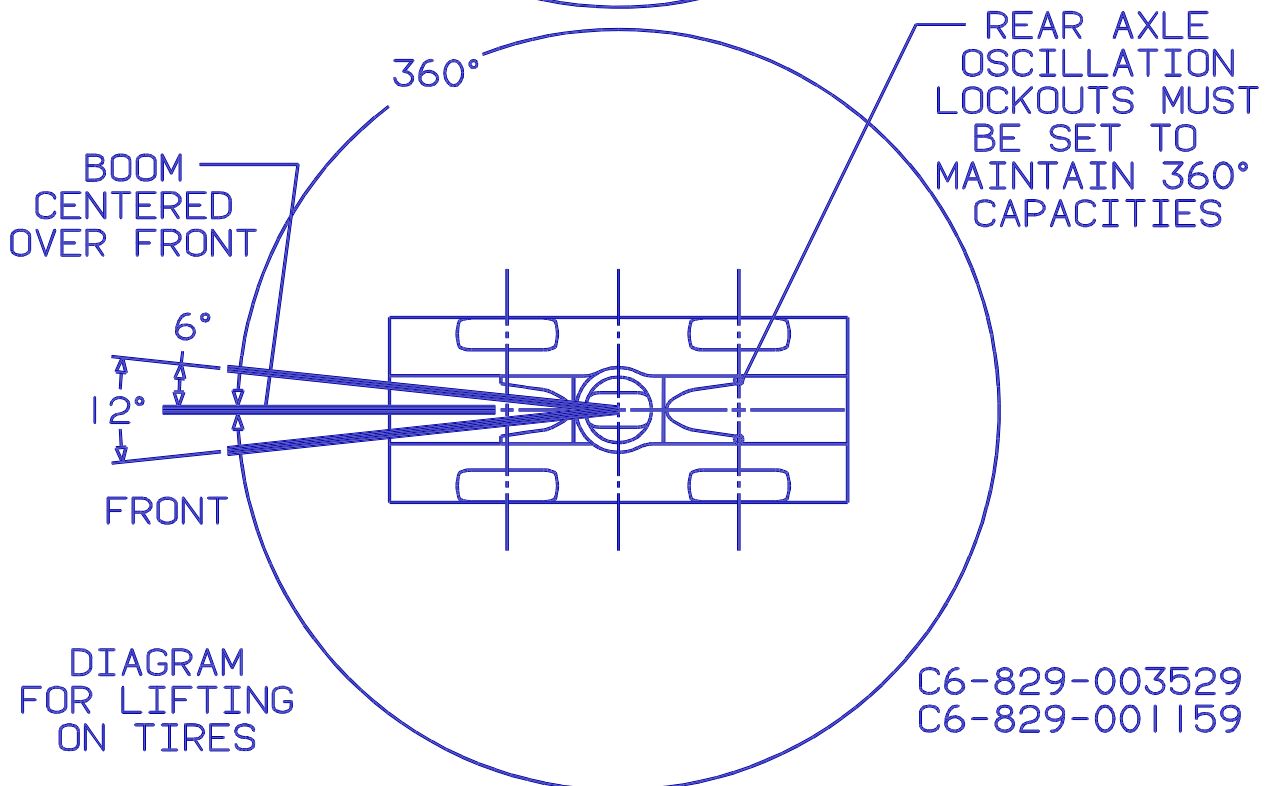
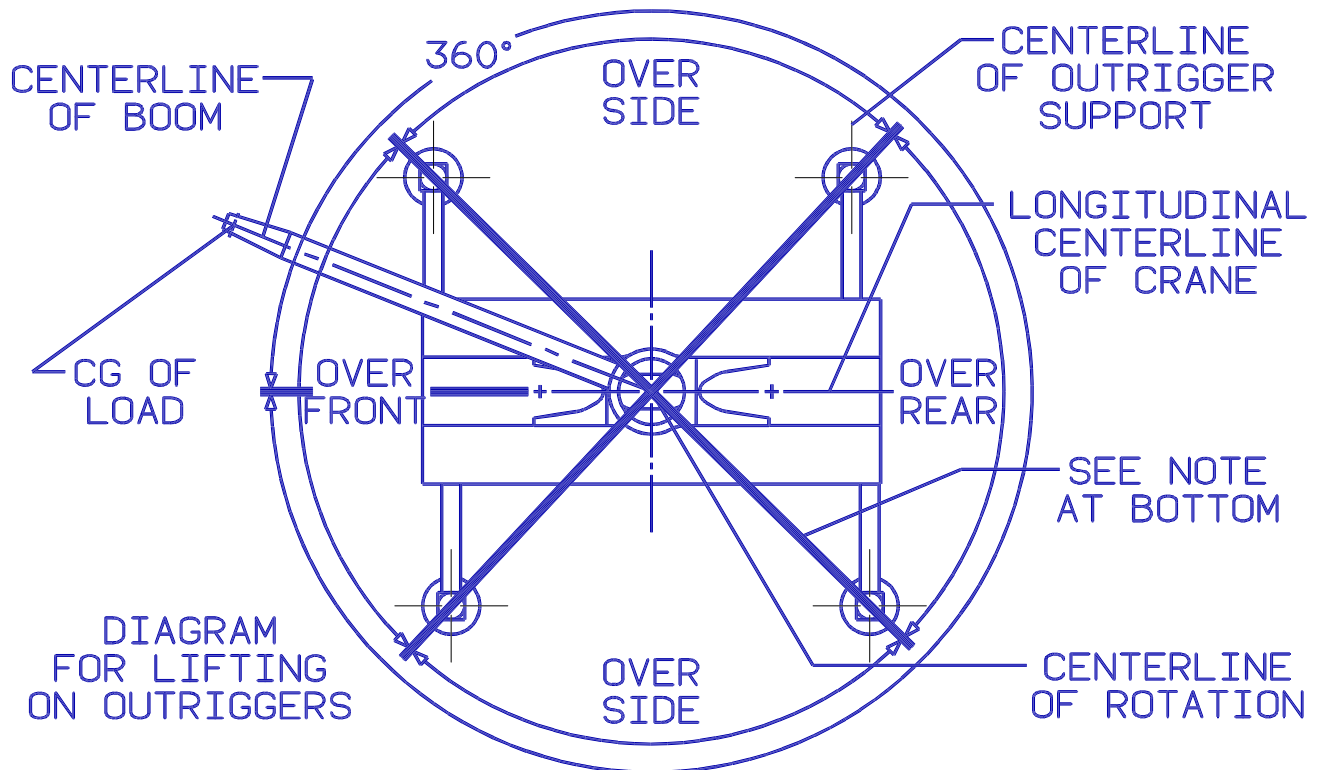

BOLD LINES DETERMINE THE LIMITING POSITION OF ANY LOAD FOR OPERATION WITHIN WORKING AREAS INDICATED  
WORKING AREA DIAGRAM

**RATED LIFTING CAPACITIES IN POUNDS**  
**34 FT. - 105 FT. BOOM**  
**ON OUTRIGGERS 50% EXTENDED (15' 9" SPREAD) - 360°**

| Radius<br>in<br>Feet                                     | #4001                    |                  |                  |                  |                  |                  |                 |                  |                  |                   |
|--|--------------------------|------------------|------------------|------------------|------------------|------------------|-----------------|------------------|------------------|-------------------|
|  | Main Boom Length in Feet |                  |                  |                  |                  |                  |                 |                  |                  |                   |
|  | 34                       | 40               | 50               | *58              | 60               | 70               | 80              | 90               | 100              | 105               |
| 10   | 70,000<br>(66)           | 66,900<br>(70)   | 58,650<br>(74.5) | 44,600<br>(76.5) | 29,300<br>(77)   |                  |                 |                  |                  |                   |
| 12   | 64,350<br>(62)           | 64,000<br>(67)   | 55,000<br>(72)   | 44,600<br>(74.5) | 29,300<br>(75)   | 29,300<br>(78)   |                 |                  |                  |                   |
| 15   | 54,050<br>(55.5)         | 53,550<br>(62)   | 48,000<br>(68.5) | 41,500<br>(71.5) | 29,300<br>(72.5) | 29,300<br>(75.5) |                 |                  |                  |                   |
| 20   | 35,000<br>(43.5)         | 33,350<br>(52.5) | 30,850<br>(61.5) | 29,350<br>(66)   | 29,250<br>(67.5) | 28,900<br>(72)   | 28,400<br>(75)  | 27,000<br>(77)   |                  |                   |
| 25   | 23,150<br>(26.5)         | 22,700<br>(42)   | 21,500<br>(54.5) | 20,450<br>(60.5) | 20,500<br>(62.5) | 20,550<br>(67.5) | 20,450<br>(71)  | 20,250<br>(74)   | 18,550<br>(75.5) | @15,850<br>(76.5) |
| 30   |                          | 16,000<br>(27.5) | 15,500<br>(46.5) | 15,050<br>(54)   | 15,150<br>(56.5) | 15,350<br>(62.5) | 15,450<br>(67)  | 15,400<br>(70.5) | 15,350<br>(72.5) | 15,250<br>(74)    |
| 35   |                          |                  | 11,400<br>(37.5) | 11,050<br>(47.5) | 11,200<br>(50)   | 11,850<br>(57.5) | 12,000<br>(63)  | 12,100<br>(67)   | 12,100<br>(69.5) | 12,100<br>(71)    |
| 40   |                          |                  | 8,590<br>(24.5)  | 8,310<br>(39.5)  | 8,450<br>(43)    | 9,050<br>(52.5)  | 9,540<br>(58.5) | 9,680<br>(63)    | 9,750<br>(66.5)  | 9,770<br>(68)     |
| 45   | See<br>Warning           |                  |                  | 6,290<br>(30)    | 6,420<br>(34.5)  | 6,990<br>(46.5)  | 7,550<br>(54)   | 7,820<br>(59)    | 7,930<br>(63)    | 7,970<br>(64.5)   |
| 50   | Note 16                  |                  |                  | 4,740<br>(13.5)  | 4,870<br>(23)    | 5,410<br>(40)    | 5,960<br>(49)   | 6,330<br>(55)    | 6,490<br>(59.5)  | 6,540<br>(61.5)   |
| 55   |                          |                  |                  |                  |                  | 4,210<br>(32)    | 4,700<br>(43.5) | 5,050<br>(51)    | 5,330<br>(56)    | 5,390<br>(58)     |
| 60   |                          |                  |                  |                  |                  | 3,240<br>(21.5)  | 3,680<br>(37.5) | 4,010<br>(46)    | 4,340<br>(52)    | 4,430<br>(54.5)   |
| 65   |                          |                  |                  |                  |                  |                  | 2,850<br>(30.5) | 3,160<br>(41)    | 3,470<br>(48)    | 3,620<br>(51)     |
| 70   |                          |                  |                  |                  |                  |                  | 2,140<br>(20.5) | 2,440<br>(35)    | 2,750<br>(43.5)  | 2,900<br>(47)     |
| 75   |                          |                  |                  |                  |                  |                  |                 | 1,840<br>(28.5)  | 2,130<br>(38.5)  | 2,270<br>(42.5)   |
| 80   |                          |                  |                  |                  |                  |                  |                 | 1,330<br>(18.5)  | 1,600<br>(33.5)  | 1,730<br>(38)     |
| 85   |                          |                  |                  |                  |                  |                  |                 |                  | 1,140<br>(26.5)  | 1,270<br>(32.5)   |
| Minimum boom angle (deg.) for indicated length           |                          |                  |                  |                  |                  |                  |                 |                  |                  | 26                |
| Maximum boom length (ft.) at 0 deg. boom angle (no load) |                          |                  |                  |                  |                  |                  |                 |                  |                  | 90                |

Note: ( ) Boom angles are in degrees.

#LMI operating code. Refer to LMI manual for instructions.

| Boom<br>Angle | Lifting Capacities at Zero Degree Boom Angle On Outriggers 50% Extended - 360° |                |               |                 |               |               |               |               |  |  |
|---------------|--|----------------|---------------|-----------------|---------------|---------------|---------------|---------------|--|--|
|               | 34   | 40             | 50            | *58             | 60            | 70            | 80            | 90            |  |  |
| 0°            | 16,350<br>(27.1)   | 12,700<br>(33) | 7,280<br>(43) | 4,550<br>(50.8) | 4,140<br>(53) | 2,740<br>(63) | 1,770<br>(73) | 1,060<br>(83) |  |  |

Note: ( ) Reference radii in feet.

A6-829-012055A

\*58 ft. boom length is with inner-mid extended and outer-mid & fly retracted.

@Capacity also applicable at maximum boom angle.

## 29 FT. FIXED LENGTH BOOM EXTENSION

### ON OUTRIGGERS 50% EXTENDED (15' 9" SPREAD) - 360°

| Radius<br>in<br>Feet | 29 ft. LENGTH   |                 |
|----------------------|-----------------|-----------------|
|                      | #4051           | #4053           |
|                      | 0° OFFSET       | 30°<br>OFFSET   |
| 30                   | 9,360<br>(77.5) |                 |
| 35                   | 8,960<br>(75.5) |                 |
| 40                   | 8,610<br>(73)   | *5,360<br>(78)  |
| 45                   | 7,700<br>(71)   | 5,160<br>(75.5) |
| 50                   | 6,340<br>(68.5) | 4,960<br>(73.5) |
| 55                   | 5,240<br>(66)   | 4,760<br>(71)   |
| 60                   | 4,320<br>(64)   | 4,320<br>(68.5) |
| 65                   | 3,540<br>(61.5) | 3,540<br>(66)   |
| 70                   | 2,880<br>(58.5) | 2,880<br>(63.5) |
| 75                   | 2,300<br>(56)   | 2,300<br>(60.5) |
| 80                   | 1,800<br>(53.5) | 1,800<br>(58)   |
| 85                   | 1,360<br>(50.5) | 1,360<br>(55)   |

A6-829-012409A

Note: ( ) Boom angles are in degrees.

#LMI operating code. Refer to LMI manual for instructions.

1. All capacities above the bold line are based on structural strength of boom extension.
2. 29 ft. boom extension length may be used for single line lifting service only.
3. Radii listed are for a fully extended boom with the boom extension erected. For main boom lengths less than fully extended, the rated loads are determined by boom angle. Use only the column which corresponds to the boom extension length and offset for which the machine is configured. For boom angles not shown, use the rating of the next lower boom angle.

**WARNING:** Operation of this machine with heavier loads than the capacities listed is strictly prohibited. Machine tipping with boom extension occurs rapidly and without advance warning.

4. Boom angle is the angle above or below horizontal of the longitudinal axis of the boom base section after lifting rated load.
5. Capacities listed are with outriggers at 15 ft. 9 in. spread and vertical jacks set only.
6. 29 FT. OFFSETTABLE BOOM EXTENSION WARNING: For main boom length greater than 60 ft. with 29 ft. tele. boom extension in working position, the boom angle must not be less than 48.5° since loss of stability will occur causing a tipping condition. The boom angle is not restricted for main boom length equal to or less than 60 ft. This warning also applies for boom extension erection purposes.

## 29 FT. - 51 FT. TELE. BOOM EXTENSION

### ON OUTRIGGERS 50% EXTENDED (15' 9" SPREAD) - 360°

| Radius in Feet | 29 ft. LENGTH   |                 | 51 ft. LENGTH   |                 |
|----------------|-----------------|-----------------|-----------------|-----------------|
|                | #4021           | #4023           | #4041           | #4043           |
|                | 0° OFFSET       | 30° OFFSET      | 0° OFFSET       | 30° OFFSET      |
| 30             | 9,000<br>(77.5) |                 |                 |                 |
| 35             | 8,600<br>(75.5) |                 | *5,065<br>(78)  |                 |
| 40             | 8,250<br>(73)   | *5,000<br>(78)  | 4,900<br>(76.5) |                 |
| 45             | 7,090<br>(71)   | 4,800<br>(75.5) | 4,700<br>(74.5) |                 |
| 50             | 5,740<br>(68.5) | 4,600<br>(73.5) | 4,400<br>(73)   |                 |
| 55             | 4,630<br>(66)   | 4,400<br>(71)   | 4,000<br>(71)   | *2,800<br>(78)  |
| 60             | 3,710<br>(64)   | 3,710<br>(68.5) | 3,800<br>(69)   | 2,700<br>(77)   |
| 65             | 2,930<br>(61.5) | 2,930<br>(66)   | 3,700<br>(67)   | 2,600<br>(75)   |
| 70             | 2,260<br>(58.5) | 2,260<br>(63.5) | 3,050<br>(65)   | 2,500<br>(72.5) |
| 75             | 1,690<br>(56)   | 1,690<br>(60.5) | 2,490<br>(62.5) | 2,400<br>(70.5) |
| 80             | 1,180<br>(53.5) | 1,180<br>(58)   | 1,990<br>(60.5) | 1,990<br>(68)   |
| 85             |                 |                 | 1,550<br>(58.5) | 1,550<br>(66)   |
| 90             |                 |                 | 1,160<br>(56)   | 1,160<br>(63.5) |

A6-829-012057A

NOTE: ( ) Boom angles are in degrees.

\*This capacity is based upon maximum boom angle.

#LMI operating code. Refer to LMI manual for instructions.

1. All capacities above the bold line are based on structural strength of boom extension.

2. 29 ft. and 51 ft. boom extension lengths may be used for single line lifting service only.

3. Radii listed are for a fully extended boom with the boom extension erected. For main boom lengths less than fully extended, the rated loads are determined by boom angle. Use only the column which corresponds to the boom extension length and offset for which the machine is configured. For boom angles not shown, use the rating of the next lower boom angle.

**WARNING:** Operation of this machine with heavier loads than the capacities listed is strictly prohibited. Machine tipping with boom extension occurs rapidly and without advance warning.

4. Boom angle is the angle above or below horizontal of the longitudinal axis of the boom base section after lifting rated load.

5. Capacities listed are with outriggers at 15 ft. 9 in. spread and vertical jacks set only.

6. 29 FT. TELE. OFFSETTABLE BOOM EXTENSION WARNING: For main boom length greater than 50 ft. with 29 ft. tele. boom extension in working position, the boom angle must not be less than 52.5° since loss of stability will occur causing a tipping condition. The boom angle is not restricted for main boom length equal to or less than 50 ft. This warning also applies for boom extension erection purposes.

51 FT. TELE. OFFSETTABLE BOOM EXTENSION WARNING: For main boom length greater than 40 ft. with 51 ft. tele. boom extension in working position, the boom angle must not be less than 55.5° since loss of stability will occur causing a tipping condition. The boom angle is not restricted for main boom length equal to or less than 40 ft. This warning also applies for boom extension erection purposes.



## RATED LIFTING CAPACITIES IN POUNDS 34 FT. - 105 FT. BOOM

ON OUTRIGGERS 0% EXTENDED (9' 3.5" SPREAD) - 360°

| Radius<br>in<br>Feet                                     | <b>#8001</b>             |                  |                  |                  |                  |                  |                 |                 |                 |                 |
|--|--------------------------|------------------|------------------|------------------|------------------|------------------|-----------------|-----------------|-----------------|-----------------|
|  | Main Boom Length in Feet |                  |                  |                  |                  |                  |                 |                 |                 |                 |
|  | 34                       | 40               | 50               | *58              | 60               | 70               | 80              | 90              | 100             | 105             |
| 10   | 47,200<br>(66)           | 44,100<br>(70)   | 39,900<br>(74.5) | 37,150<br>(76.5) | 29,300<br>(77)   |                  |                 |                 |                 |                 |
| 12   | 36,100<br>(62)           | 33,900<br>(67)   | 30,900<br>(72)   | 28,950<br>(74.5) | 28,800<br>(75)   | 28,000<br>(78)   |                 |                 |                 |                 |
| 15   | 24,700<br>(55.5)         | 24,250<br>(62)   | 22,450<br>(68.5) | 21,100<br>(71.5) | 21,100<br>(72.5) | 20,850<br>(75.5) |                 |                 |                 |                 |
| 20   | 15,050<br>(43.5)         | 14,650<br>(52.5) | 14,200<br>(61.5) | 13,050<br>(66)   | 13,200<br>(67.5) | 13,750<br>(72)   | 13,750<br>(75)  | 13,650<br>(77)  |                 |                 |
| 25   | 10,050<br>(26.5)         | 9,660<br>(42)    | 8,950<br>(54.5)  | 8,400<br>(60.5)  | 8,530<br>(62.5)  | 9,120<br>(67.5)  | 9,720<br>(71)   | 9,780<br>(74)   | 9,760<br>(75.5) | 9,740<br>(76.5) |
| 30   |                          | 6,270<br>(27.5)  | 5,880<br>(46.5)  | 5,570<br>(54)    | 5,690<br>(56.5)  | 6,230<br>(62.5)  | 6,780<br>(67)   | 7,170<br>(70.5) | 7,240<br>(72.5) | 7,260<br>(74)   |
| 35   |                          |                  | 3,930<br>(37.5)  | 3,680<br>(47.5)  | 3,790<br>(50)    | 4,300<br>(57.5)  | 4,800<br>(63)   | 5,190<br>(67)   | 5,410<br>(69.5) | 5,460<br>(71)   |
| 40   |                          |                  | 2,540<br>(24.5)  | 2,320<br>(39.5)  | 2,430<br>(43)    | 2,910<br>(52.5)  | 3,390<br>(58.5) | 3,740<br>(63)   | 4,030<br>(66.5) | 4,090<br>(68)   |
| 45   | See<br>Warning           |                  |                  | 1,300<br>(30)    | 1,400<br>(34.5)  | 1,860<br>(46.5)  | 2,320<br>(54)   | 2,650<br>(59)   | 2,950<br>(63)   | 3,020<br>(64.5) |
| 50   | Note 16                  |                  |                  |                  |                  | 1,050<br>(40)    | 1,500<br>(49)   | 1,800<br>(55)   | 2,080<br>(59.5) | 2,160<br>(61.5) |
| 55   |                          |                  |                  |                  |                  |                  |                 | 1,120<br>(51)   | 1,370<br>(56)   | 1,450<br>(58)   |
| Minimum boom angle (deg.) for indicated length           |                          |                  |                  |                  |                  |                  |                 |                 |                 | 55.5            |
| Maximum boom length (ft.) at 0 deg. boom angle (no load) |                          |                  |                  |                  |                  |                  |                 |                 |                 | 50              |

Note: ( ) Boom angles are in degrees.

#LMI operating code. Refer to LMI manual for instructions.

| Boom<br>Angle | <b>Lifting Capacities at Zero Degree Boom Angle On Outriggers 0% Extended (9' 3.5" Spread) - 360°</b> |               |               |  |  |  |  |  |  |  |
|---------------|---|---------------|---------------|--|--|--|--|--|--|--|
|               | 34  | 40            | 50            |  |  |  |  |  |  |  |
| 0°            | 8,090<br>(27.1)   | 4,980<br>(33) | 1,880<br>(43) |  |  |  |  |  |  |  |

Note: ( ) Reference radii in feet.

A6-829-012056

\*58 ft. boom length is with inner-mid extended and outer-mid & fly retracted.

@Capacity also applicable at maximum boom angle.





### TIRE INFLATION - PSI (BAR)

| SIZE<br>(FRONT<br>&<br>REAR) | LOAD<br>RANGE | LIFTING SERVICE , GENERAL<br>TRAVEL AND EXTENDED TRAVEL |
|------------------------------|---------------|---|
|                              |               | STATIC, CREEP &<br>2.5 MPH (4.0 km/h)                   |
| 23.5R25<br>GOODYEAR          | * *           | 80 (5.5)  |
| 23.5R25<br>MICHELIN          | *             | 75 (5.2)  |
| 23.5R25<br>MICHELIN          | 185B          | 75 (5.2)  |