

RT522

**22 TON CAPACITY
28 ft. - 70 ft. BOOM**

(FULL POWER)

PCSA CLASS 10-80

85% OF TIPPING - ON OUTRIGGERS

75% OF TIPPING - ON RUBBER

JIB CAPACITIES IN POUNDS

23 ft. "A" FRAME JIB

MAIN BOOM ANGLE	0° OFFSET		15° OFFSET		30° OFFSET	
	Radius (Ref.)	Cap. lbs.	Radius (Ref.)	Cap. lbs.	Radius (Ref.)	Cap. lbs.
75°	27.0	12,000	32.5	7,700	35.7	5,070
70	33.3	10,400	38.1	7,000	41.2	4,800
65	40.2	8,300	44.9	6,300	47.8	4,500
60	47.0	5,870	51.3	5,450	54.0	4,300
55	53.2	4,450	57.3	4,080	59.8	3,690
50	59.2	3,560	62.9	3,170	65.1	3,030
45	64.7	2,910	68.0	2,610	69.9	2,590
40	69.6	2,400	72.6	2,230	74.2	2,160
35	74.0	2,020	76.6	1,920	77.9	1,880
30	77.8	1,730	80.1	1,680	81.0	1,670

A6-829-0037551

23 ft. - 38 ft. TELE. JIB

Boom Angle	23 ft. Jib Length (Fully Retracted)						33 ft. Jib Length						38 ft. Jib Length (Fully Extended)					
	0° Offset		15° Offset		30° Offset		0° Offset		15° Offset		30° Offset		0° Offset		15° Offset		30° Offset	
	Radius (Ref.) ft.	Cap. lbs.	Radius (Ref.) ft.	Cap. lbs.	Radius (Ref.) ft.	Cap. lbs.	Radius (Ref.) ft.	Cap. lbs.	Radius (Ref.) ft.	Cap. lbs.	Radius (Ref.) ft.	Cap. lbs.	Radius (Ref.) ft.	Cap. lbs.	Radius (Ref.) ft.	Cap. lbs.	Radius (Ref.) ft.	Cap. lbs.
75°	27.5	12,500	31.4	7,300	35.0	4,500	29.0	7,600	35.3	4,900	41.5	2,900	31.0	5,000	39.0	3,750	45.4	2,230
70	33.3	9,390	37.8	6,390	40.6	4,150	35.9	6,500	42.5	4,270	48.8	2,650	37.9	4,650	45.6	3,300	51.8	1,990
65	40.2	6,670	44.7	5,750	47.2	3,900	43.9	5,300	50.2	3,820	56.1	2,440	46.3	4,470	53.7	2,950	59.3	1,870
60	47.0	5,020	51.3	4,630	53.6	3,680	51.6	4,300	57.5	3,450	62.8	2,330	54.3	3,550	61.2	2,640	66.4	1,770
55	53.2	3,860	57.3	3,420	59.5	3,120	58.8	3,320	64.3	2,770	69.2	2,230	62.0	2,910	68.4	2,450	72.9	1,680
50	59.2	3,080	62.9	2,790	65.1	2,650	65.7	2,590	70.7	2,190	74.9	1,910	69.2	2,430	75.0	2,030	78.9	1,620
45	64.7	2,450	68.0	2,280	69.9	2,180	71.9	2,060	76.5	1,730	80.2	1,600	75.8	1,920	81.1	1,660	84.3	1,500
40	69.6	1,980	72.6	1,870	74.2	1,750	77.7	1,640	81.7	1,400	84.7	1,360	81.8	1,480	86.4	1,360	89.0	1,240
35	74.0	1,580	76.6	1,530	77.9	1,440	82.8	1,300	86.2	1,150	88.6	1,130	87.2	1,080	91.2	1,020	93.0	980
30	77.8	1,290	80.1	1,270	81.0	1,230	87.3	1,020	90.2	940	91.8	920	92.0	860	95.2	840	96.3	830

A6-829-003907F

No load stability on outriggers 360° with 23 ft. - 38 ft. tele-jib installed:

	Tele-jib fully Retracted 93 ft.	33 ft. Tele-jib Length 103 ft.	Tele-jib fully Extended 108 ft.
Minimum boom angle for indicated boom length	0°	0°	0°
Maximum boom length including jib for 0° boom angle	93 ft.	103 ft.	108 ft.

NOTES FOR JIB CAPACITIES

- 23 ft. jib and 23 ft. tele. jib length may be used for double lifting service. 33 ft. and 38 ft. tele. jib lengths may be used for single lifting service only. Capacities are based on structural strength of every jib at a given main boom angle regardless of main boom length.
- WARNING:** Operation of machine with heavier loads than the capacities listed is strictly prohibited. Machine tipping with jib occurs rapidly and without advance warning.
- Capacities listed are with fully extended outriggers only.
- WARNING:** Lifting on rubber with jib is prohibited.
- Reference radii listed are for fully extended main boom only.
- No load stability on outriggers with:
23 ft. Jib Installed —
a. Minimum boom angle for fully extended main boom = 0°
b. Maximum boom length at 0° main boom angle = 93 ft.

Courtesy of Crane.Market



RT52

22 TON CAPACITY
28 ft. - 70 ft. BOOM

(FULL POWER)
PCSA CLASS 10-8
85% OF TIPPING - ON OUTRIGGERS
75% OF TIPPING - ON RIG

RATED LIFTING CAPACITIES

28 ft. - 70 ft. BOOM

ON OUTRIGGERS FULLY EXTENDED - 360°

Radius in Feet	Boom Length in Feet							
	28	34	40	46	52	58	64	70
10	44,000 (64)	36,000 (69)	36,000 (73)					
12	40,000 (59.5)	36,000 (65.5)	36,000 (70)	35,000 (73)				
15	31,000 (51.5)	31,000 (59.5)	30,700 (65)	29,850 (69)	29,150 (72)	28,600 (74.5)		
20	23,200 (36.5)	23,200 (49)	23,200 (57)	23,200 (62)	23,000 (66)	22,600 (69.5)	22,150 (72)	20,500 (74)
25	17,950 (6)	17,950 (36)	17,950 (47.5)	17,950 (54.5)	17,950 (60)	17,950 (64)	17,950 (67)	17,650 (69.5)
30		13,470 (15.5)	13,470 (36.5)	13,470 (46.5)	13,470 (53)	13,470 (58)	13,470 (62)	13,470 (65)
35			10,220 (20)	10,220 (36.5)	10,220 (45.5)	10,220 (51.5)	10,220 (56.5)	10,220 (60)
40	See Warning Note 1c			8,010 (23)	8,010 (36.5)	8,010 (45)	8,010 (50.5)	8,010 (55)
45					6,530 (25)	6,530 (37)	6,530 (44.5)	6,530 (49.5)
50						5,430 (26.5)	5,430 (37)	5,430 (43.5)
55						4,440 (3.5)	4,440 (28)	4,440 (37)
60							3,620 (13)	3,620 (28.5)
65								2,980 (15.5)
Min. boom angle (deg.) for indicated length [No Load]								0
Max. boom length (ft.) at 0 degree boom angle [No Load]								70.0

NOTE: Boom Angles are in degrees.

A6-829-003710 & -003716G

14.00x24 TIRES

Radius in Feet	Stationary Capacity	Stationary Capacity	Pick & Carry Cap. Up to 2.5 MPH
	Defined Arc (3) Over Front	360° Arc	Boom Centered (7) Over Front
10	25,600 (a)	21,100 (a)	21,610 (a)
12	21,500 (a)	15,780 (a)	18,520 (a)
15	17,770 (a)	10,430 (b)	15,050 (a)
20	12,840 (b)	5,950 (c)	12,060 (a)
25	8,480 (b)	3,570 (d)	8,480 (b)
30	6,230 (c)	2,320 (e)	6,230 (c)
35	4,650 (d)	1,470 (f)	4,650 (d)
40	3,520 (e)	910 (f)	3,000 (d)
45	2,660 (f)		2,270 (e)
50	2,020 (g)		1,680 (f)
55	1,520 (g)		1,220 (f)
60	1,130 (h)		
65	880 (h)		

A6-829-003763F

Maximum Permissible Boom Length:

- (a) 28 ft. (e) 52 ft.
- (b) 34 (f) 58
- (c) 40 (g) 64
- (d) 46 (h) 70

	Min. Boom Angle (deg.) for Indicated Boom Length	0	0
Front (No Load)	Max. Boom Length (ft.) at 0 degree Boom Angle	70	93
360° (No Load)	Min. Boom Angle (deg.) for Indicated Boom Length	42	51
	Max. Boom Length (ft.) at 0 degree Boom Angle	52	57

ON OUTRIGGERS FULLY EXTENDED - OVER FRONT

Radius in Feet	Boom Length in Feet							
	28	34	40	46	52	58	64	70
10	44,000 (64)	36,000 (69)	36,000 (73)					
12	40,000 (59.5)	36,000 (65.5)	36,000 (70)	35,000 (73)				
15	31,000 (51.5)	31,000 (59.5)	30,700 (65)	29,850 (69)	29,150 (72)	28,600 (74.5)		
20	23,200 (36.5)	23,200 (49)	23,200 (57)	23,200 (62)	23,000 (66)	22,600 (69.5)	22,150 (72)	20,500 (74)
25	17,950 (6)	17,950 (36)	17,950 (47.5)	17,950 (54.5)	17,950 (60)	17,950 (64)	17,950 (67)	17,650 (69.5)
30		15,350 (15.5)	15,350 (36.5)	15,350 (46.5)	15,350 (53)	15,150 (58)	14,950 (62)	14,750 (65)
35			11,900 (20)	11,900 (36.5)	11,900 (45.5)	11,900 (51.5)	11,900 (56.5)	11,900 (60)
40	See Warning Note 1c			9,410 (23)	9,410 (36.5)	9,410 (45)	9,410 (50.5)	9,410 (55)
45					7,720 (25)	7,720 (37)	7,720 (44.5)	7,720 (49.5)
50						6,410 (26.5)	6,410 (37)	6,410 (43.5)
55							5,410 (3.5)	5,410 (28)
60								4,530 (13)
65								3,780 (15.5)
Min. boom angle (deg.) for indicated length [No Load]								0
Max. boom length (ft.) at 0 degree boom angle [No Load]								70.0

NOTE: Boom Angles are in degrees.

A6-829-003704 & -003716G

GENERAL:

- Rated loads as shown on lift chart pertain to this machine as and equipped. Modifications to the machine or use of options that specified can result in a reduction of capacity.
- Construction equipment can be hazardous if improperly operated. Operation and maintenance of this machine shall be in accordance with information in the operator's, parts, and safety manuals supplied. If these manuals are missing, order replacements from the manufacturer.
- The operator and other personnel associated with this machine shall themselves with the latest applicable American National Standards for cranes.

SETUP:

- The machine shall be leveled on a firm supporting surface. If the supporting surface, it may be necessary to have structural outrigger floats or tires to spread the load to a larger bearing surface.
- For outrigger operation, outriggers shall be fully extended and crane weight before operating the boom or lifting loads.
- If machine is equipped with front jack cylinder, the front jack shall be fully extended before operation.
- If machine is equipped with extendable counterweight, the counterweight shall be fully extended before operation.
- Tires shall be inflated to the recommended pressure before lifting.
- With certain boom and hoist tackle combinations, maximum capacity shall be obtainable with standard cable lengths.

OPERATION:

- Rated loads at rated radius shall not be exceeded. Do not determine allowable loads. For clamshell or concrete bucket bucket and load must not exceed 80% of rated lifting capacity.
- Rated loads do not exceed 85% of the tipping load as determined by the Stability Test Code J-765a.
- Rated loads include the weight of hook block, slings and auxiliary weights shall be subtracted from the listed ratings to obtain net lifting capacity.
- Load ratings are based on freely suspended loads. No attempt shall be made to lift a load horizontally on the ground in any direction.
- Rated loads do not account for wind on lifted load or boom. When wind velocity is above 20 mph (32 km/h), rated loads shall be appropriately reduced.

Courtesy of CraneMarket

ON RUBBER CAPACITIES

16.00x25 TIRES

Radius in Feet	Stationary Capacity	Stationary Capacity	Pick&CarryCap Up to 2.5 mph
	Defined Arc (3) Over Front	360° Arc	Boom Centered (7) Over Front
10	29,150 (a)	19,640 (a)	30,460 (a)
12	24,030 (a)	14,600 (a)	26,320 (a)
15	20,150 (a)	10,390 (b)	21,670 (a)
20	13,350 (b)	5,980 (c)	13,350 (a)
25	8,610 (b)	3,500 (d)	8,290 (b)
30	6,290 (c)	2,160 (e)	6,290 (c)
35	4,650 (d)	1,430 (f)	4,650 (d)
40	3,620 (e)	810 (f)	3,620 (d)
45	2,800 (f)		2,800 (e)
50	2,120 (g)		2,120 (f)
55	1,630 (g)		1,630 (f)
60	1,240 (h)		
65	960 (h)		

A6-829-003757F

20.5x25 TIRES

Radius in Feet	Stationary Capacity		Pick & Carry Capacity Up to 2.5 MPH
	Defined Arc Over Front (3)	360° Arc	Boom Centered Over Front (7)
10	28,380 (a)	24,450 (a)	26,020 (a)
12	23,800 (a)	17,190 (a)	22,420 (a)
15	19,100 (a)	11,640 (b)	18,380 (a)
20	13,940 (b)	7,180 (c)	13,940 (a)
25	9,160 (b)	4,330 (c)	9,160 (b)
30	6,640 (c)	2,930 (d)	4,830 (c)
35	5,100 (d)	2,000 (e)	3,790 (d)
40	4,020 (e)	1,370 (f)	3,020 (d)
45	3,140 (f)	880 (g)	2,310 (e)
50	2,430 (g)		1,710 (f)
55	1,860 (g)		1,210 (f)
60	1,440 (h)		
65	1,100 (h)		

A6-829-003745G

NOTES FOR RUBBER CAPACITIES

- Capacities do not exceed 75% of tipping loads as determined by test in accordance with SAE J-765.
- Capacities are applicable to machines equipped with:

14:00x24 (20 ply)	Cold Inflation	2.5 MPH
16.00x25 (20 ply)	115 PSI	110 PSI
20.5x25 (20 ply)	95 PSI	80 PSI
	80 PSI	65 PSI

- Defined Arc - Over front includes $\pm 6^\circ$ on either side of longitudinal centerline of machine.
- Capacities appearing above bold line are based on structural strength and tipping should not be relied upon as a capacity limitation.
- Capacities are applicable only with machine on a firm level surface.
- On rubber lifting with jib not permitted.
- For pick and carry operation, boom must be centered over front of machine and mechanical swing lock engaged. When handling loads in the structural range with capacities close to maximum ratings, travel should be reduced to creep speed.
- Axle lockouts must be functioning before lifting on rubber. (Check automatic lockout system for proper functioning: Refer to "Operation and Maintenance Manual" for description of a proper functioning axle lockout system).
- All lifting depends on proper tire inflation, capacity and condition. Capacities must be reduced for lower tire inflation pressures. See lifting capacity chart for tire used. Damaged tires are hazardous to safe operation of crane.

LIFTING CAPACITY NOTES

as originally manufactured
tional equipment other than

ly operated or maintained.
e in compliance with the
supplied with this machine.
e manufacturer through the

machine shall fully acquaint
Standards Institute (ANSI)

ce. Depending on the nature
structural supports under the
ing surface.

ded with tires raised free of

jack cylinder shall be set in

the counterweight shall be

re lifting on rubber.

imum capacities may not be

do not tip the machine to
ucket operation, weight of
capacities.

as determined by SAE Crane

auxiliary lifting devices and
to obtain the net load to be

empt shall be made to move

r boom. It is recommended
oads and boom lengths shall

- Rated loads are for lift crane service only.
- Do not operate at a radius or boom length where capacities are not listed. At these positions the machine may overturn without any load on the hook.
- The maximum load which can be telescoped is not definable because of variations in loadings and crane maintenance, but it is safe to attempt retraction and extension within the limits of the capacity chart.
- When either boom length or radius or both are between values listed, the smallest load shown at either the next larger radius or boom length shall be used.
- For safe operation, the user shall make due allowances for his particular job conditions, such as: soft or uneven ground, out of level conditions, high winds, side loads, pendulum action, jerking or sudden stopping of loads, hazardous conditions, experience of personnel, two machine lifts, traveling with loads, electric wires, etc. Side pull on boom or jib is extremely dangerous.
- Power telescoping boom sections must be extended equally at all times.
- Handling of personnel from the boom is not authorized except with equipment furnished and installed by Grove Manufacturing Company.
- Keep load handling devices a minimum of 12 inches (30 cm) below boom head when lowering or extending boom.
- Loaded boom angles give an approximation of the operating radius at specified boom lengths. The boom angle before loading should be greater to account for deflection.
- Capacities appearing above bold line are based on structural strength and tipping should not be relied upon as a capacity limitation.
- Capacities for 28 ft. (8.6m) boom length shall be lifted with the boom fully retracted. If boom is not fully retracted, capacities shall not exceed those shown for the 34 ft. (10.4m) boom length.

DEFINITIONS:

- Operating Radius: Horizontal distance from a projection of the axis of rotation to the supporting surface before loading to the center of the vertical hoist line or tackle with load applied.
- Loaded Boom Angle (Shown in Parenthesis on Main Boom Capacity Chart): is the angle between the boom base section and the horizontal, after lifting the rated load at the rated radius.
- Working Area: Areas measured in a circular arc about the center line of rotation as shown on the working area diagram.
- Freely Suspended Load: Load hanging free with no direct external force applied except by the lift cable.
- Side Load: Horizontal force applied to the lifted load either on the ground or in the air.

Courtesy of Crane.Market

GROVE®

RT522

RANGE DIAGRAM

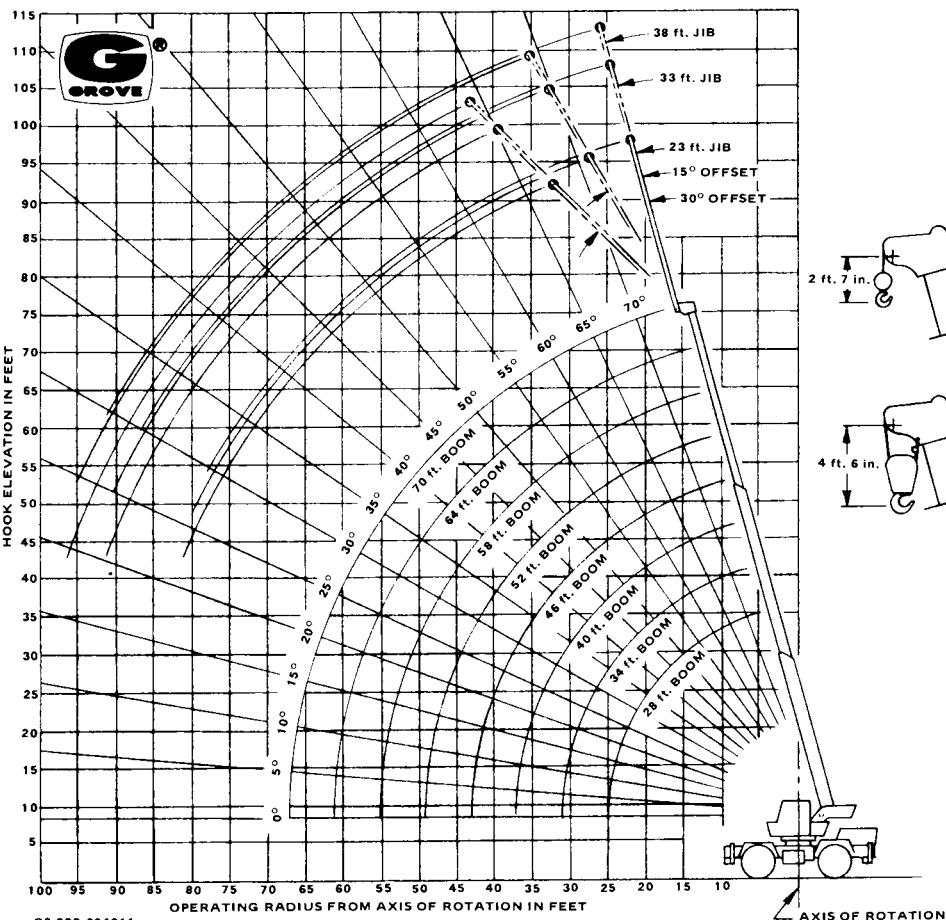

C6-829-004011

WEIGHT REDUCTIONS FOR LOAD HANDLING DEVICES

23 ft. JIB with 28-70 ft. BOOM	
*Stowed	- 381 lbs.
*Erected	- 1,950 lbs.

23-38 ft. TELE. JIB with 28-70 ft. BOOM	
*Stowed	- 604 lbs.
*Erected (Retracted)	- 3,659 lbs.
*Erected (Extended)	- 4,583 lbs.
*Reduction of main boom capacities.	

HOOK BLOCKS	
22 Ton, 3 Sheave	490 lb.
15 Ton, 2 Sheave	300 lb.
12 Ton, 1 Sheave (15 7/8" OD)	400 lb.
12 Ton, 1 Sheave (12 1/8" OD)	285 lb.
Auxiliary Boom Head	100 lb.
5 Ton Headache Ball	150 lb.

NOTE: All Load Handling Devices and Boom Attachments are Considered Part of the Load and Suitable Allowances MUST BE MADE for Their Combined Weights. Weights are for Grove furnished equipment.

LIFTING AREA DIAGRAMS

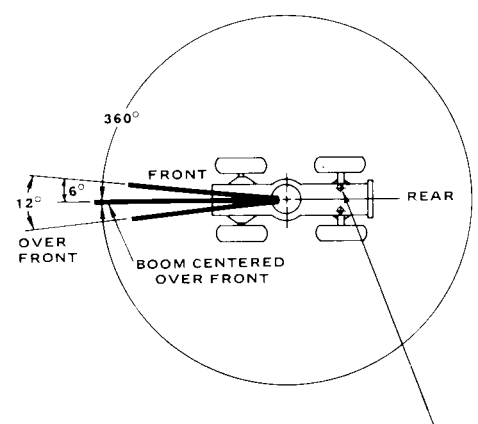

REAR AXLE OSCILLATION LOCKOUTS MUST BE SET TO MAINTAIN 360° CAPACITIES.

NOTE: BOLD LINES DETERMINE THE LIMITING POSITION OF ANY LOAD FOR OPERATION WITHIN ANY WORKING AREAS INDICATED.

C6-829-003529

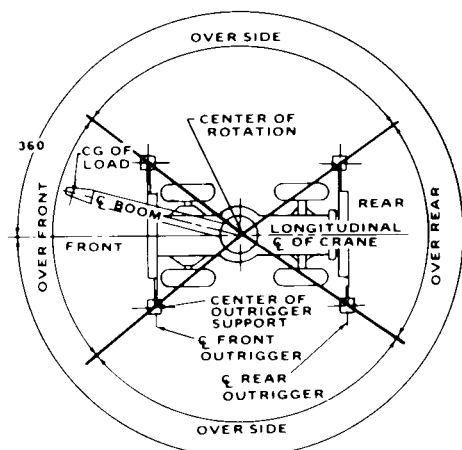

NOTE: BOLD LINES DETERMINE THE LIMITING POSITION OF ANY LOAD FOR OPERATION WITHIN WORKING AREAS INDICATED.

NOTE: OVER SIDE CAPACITIES CAN BE LIFTED IN THE OVER REAR AREA.

C6-829-001159