

GROVE®

RT700E

product guide

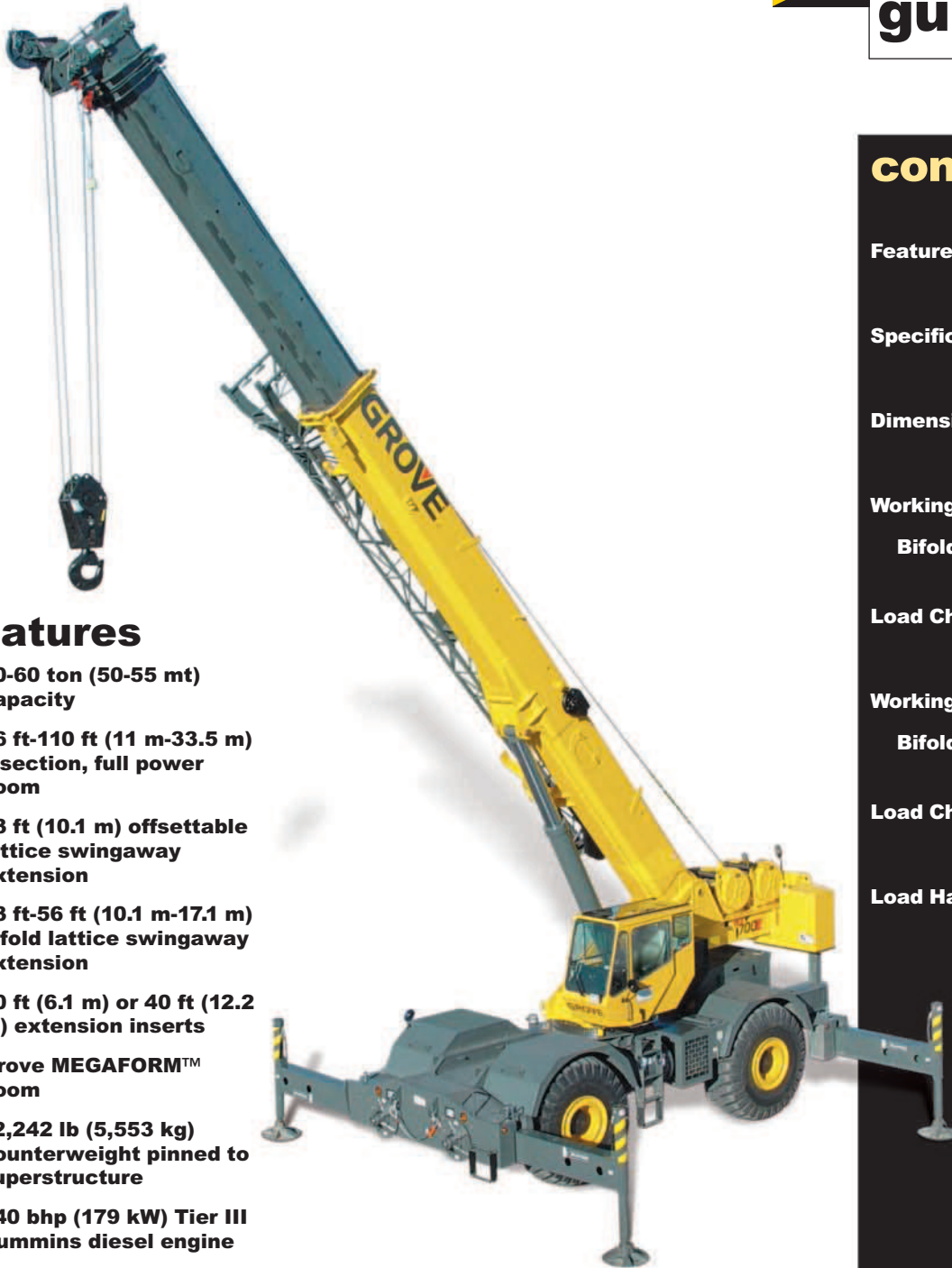

features

- 50-60 ton (50-55 mt) capacity
- 36 ft-110 ft (11 m-33.5 m) 4 section, full power boom
- 33 ft (10.1 m) offsettable lattice swingaway extension
- 33 ft-56 ft (10.1 m-17.1 m) bifold lattice swingaway extension
- 20 ft (6.1 m) or 40 ft (12.2 m) extension inserts
- Grove MEGAFORM™ boom
- 12,242 lb (5,553 kg) counterweight pinned to superstructure
- 240 bhp (179 kW) Tier III Cummins diesel engine
- Grove "E" Series cab

contents

Features	2
Specifications	3
Dimensions	5
Working Range Bifold	6
Load Charts	7
Working Range Bifold & Inserts	10
Load Charts	11
Load Handling	15



www.manitowoccrane.com

Rough Terrain Hydraulic Crane

*Product may be shown with optional equipment.

Courtesy of Crane.Market

features

2



The superstructure features a full-power four-section MEGAFORM boom that can reach to a maximum tip height of 119 ft. The sequence synchronized extension features telescopic boom sections via a single lever joystick controller.



An optional bi-fold swingaway lattice extension easily stows on the side of the base boom for easy transport while providing on-board extension from 33-56 ft. for a maximum tip height of 174.5 ft. By adding inserts of 20 or 40 ft. the max tip height on the RT700E can be extended even further to 194 ft. or 214 ft.



An optional 33 ft. fixed swingaway is also available with a max tip height of 150 ft.



The RT700E has a quick-reeve boom nose and swingaway alignment device to help operators set up smoothly.



The features common to the Grove "E" Series cab include:

- hot water heater/defroster
- single axis joystick controllers
- sliding skylight and adjustable sunscreen
- engine instrumentation
- full acoustical lining



The PAT IFlex 5 graphic display LMI includes a work area definition system which allows the operator to define a preferred working area.



Large open stowage compartment for tools and rigging accessories.



specifications

3

Superstructure

Boom

36 ft. - 110 ft. (11 m - 33.5 m) four-section, full-power sequenced synchronized boom.

Maximum tip height: 119 ft. (36.4 m).

*Optional Fixed Swingaway Extension

33 ft. (10.1 m) offsettable lattice swingaway extension. Offsettable at 0°, 25° and 45°. Stows alongside base boom section. Maximum tip height: 150 ft. (45.8 m).

*Optional Bi-Fold Swingaway Extension

33 ft. - 56 ft. (10.1 m - 17.1 m) bi-fold lattice swingaway extension. Offsettable at 0°, 25° and 45°. Stows alongside base boom section. Maximum tip height: 174.5 ft. (53.2 m).

*Optional 20 ft. (6.1 m) or 40 ft. (12.2 m) Inserts

Installs between boom nose and bi-fold extension, non-stowable. Maximum tip height: 194 ft. (59.1 m) w/20 ft. insert, 214 ft. (65.2 m) w/40 ft. insert.

Boom Nose

Three nylatron sheaves (four with 60-ton rating) mounted on heavy-duty tapered roller bearings with removable pin-type rope guards. Quick-reeve type boom nose.

*Optional removable auxiliary boom nose with removable pin type rope guard.

Boom Elevation

One double-acting hydraulic cylinder with integral holding valve provides elevation from -3° to 78°.

Load Moment & Anti-Two Block System

Standard "Graphic Display" load moment and anti-two block system with audio-visual warning and control lever lockout. These systems provide electronic display of boom angle, length, radius, tip height, relative load moment, maximum permissible load, load indication and warning of impending two-block condition. The standard Work Area Definition System allows the operator to pre-select and define safe working areas. If the crane approaches the pre-set limits, audio-visual warnings aid the operator in avoiding job-site obstructions.

Cab

Full-vision, all-steel fabricated with acoustical lining and tinted safety glass throughout. Deluxe seat incorporates armrest-mounted hydraulic single-axis controllers. Dash panel incorporates gauges for all engine functions. Other standard features include: hot water heater, cab circulating air fan, sliding side and rear windows, sliding skylight with electric wiper and sunscreen, electric windshield wash/wipe, fire extinguisher and seat belt.

Swing

Planetary swing with foot-applied multi-disc brake. Spring applied, hydraulically-released swing brake and plunger-type, one position, mechanical house lock operated from cab.

*Optional 360° mechanical swing lock. Maximum speed: 2.5 RPM.

Counterweight

12,242 lbs. (5553 kg) pinned to superstructure.

Hydraulic System

Three main gear pumps with a combined capacity of 103 GPM (391 LPM), 135 GPM (511 LPM) with optional air conditioning. Maximum operating pressure: 4000 psi (27.6 MPa). Two individual post pressure compensated valve banks.

Return line type filter with full flow by-pass protection and service indicator. Replaceable cartridge with micron filtration rating of 5/12/16. 132 gallon (500 L) reservoir. Integral oil cooler. System pressure test ports.

Hoist Specifications

Main and Auxiliary Hoist: Model HP30A-19G

Planetary reduction with automatic spring applied multi-disc brake. Grooved drum. Electronic hoist drum rotation indicator and hoist drum cable followers.

Maximum Single Line Pull: 20,250 lbs
(8 246 kg)

Maximum Single Line Speed: 542 FPM
(179 m/min)

Maximum Permissible Line Pull:
16,800 lbs. (7 620 kg) w/standard 6 x 37 class rope
16,800 lbs. (7 620 kg) w/optional 35 x 7 class rope

Rope Diameter: 3/4 in. (19 mm)

Rope Length: 500 ft. (152 m)
*Optional 550 ft. (168 m) 35 x 7 class rope

Rope Type:
6 x 37 class EIPS IWRC
*Optional 35 x 7 class rotation resistant

Maximum Rope Stowage: 694 ft. (211 m)

RT700E

specifications

4

Carrier

Chassis

Box section frame fabricated from high-strength, low alloy steel. Integral outrigger housings and front/rear towing and tie down lugs.

Outrigger System

Four hydraulic telescoping single-stage double box beam outriggers with inverted jacks and integral holding valves. Three position settings, 100%, 50% and fully retracted. All steel fabricated, quick-release type round outrigger floats, 24 in. (610 mm) diameter. Maximum outrigger pad load: 80,700 lbs (36,606 kg).

Outrigger Controls

Controls and crane level indicator located in cab.

Engine (Tier III)

Cummins QSB 6.7L diesel, six cylinders, turbocharged, 240 bhp (179 kW) (Gross) @ 2,500 rpm. Maximum torque: 728 ft. lbs. (987 N-m) @ 1,500 RPM.

Fuel Tank Capacity

72 gallons (273 L)

Transmission

Spicer powershift with 6 forward and 6 reverse speeds (3 speeds high and 3 speeds low). Front axle disconnect for 4 x 2 travel.

Electrical System

Two 12-volt maintenance free batteries. 12-volt starting and lighting, circuit breakers, battery disconnect switch.

Drive

4 x 4

Steering

Fully independent power steering:

Front: Full hydraulic, steering wheel controlled.

Rear: Full hydraulic, switch controlled.

Provides infinite variations of 4 main steering modes: front only, rear only, crab and coordinated.

Rear steer centered indicating light.

4 wheel turning radius - 22 ft. 2 in. (6.7 m).

Axles

Front: Drive/steer with differential and planetary reduction hubs rigid-mounted to frame.

Rear: Drive/steer with differential and planetary reduction hubs pivot-mounted to frame.

Automatic full hydraulic lockouts on rear axle permit 8 in. (203 mm) oscillation only with boom centered over the front.

Brakes

Full hydraulic split circuit brakes operating on all wheels. Spring-applied, hydraulically released axle-mounted parking brake.

Tires

29.5 x 25 - 28PR bias earthmover type.

Lights

Full lighting package including turn indicators, head, tail, brake and hazard warning lights.

Maximum Speed

23 MPH (37 km/h).

Gradeability (Theoretical)

75% (Based on 89,951 lbs. [40 802 kg] GVW) 29.5 x 25 tires, pumps engaged, 110 ft. (33.6 m) boom, bi-fold extension, aux. hoist and cable, and 60T hookblock.

Miscellaneous Standard Equipment

Full width steel fenders, dual rear view mirrors, hookblock tiedown, electronic back-up alarm, light package, front stowage well, tachometer, rear wheel position indicator, 36,000 BTU hot water heater, hoist mirrors, engine distress A/V warning system. Auxiliary hoist control valve arrangement (less hoist). Cold start aid and immersion type engine block heater, 120V 1500 watt.

*Optional Equipment

*Auxiliary Hoist Package (includes Model HP30A-19G auxiliary hoist with electronic hoist drum rotation indicator, hoist drum cable follower, 500 ft. (152 m) of 3/4 in. (19 mm) 35 X 7 class wire rope, auxiliary single sheave boom nose.)

*AIR CONDITIONING PACKAGE (includes hydraulic driven 28,500 BTU air conditioning)

*Auxiliary Lighting Package (includes cab mounted amber flashing light, 360° rotation spotlight and dual base boom mounted floodlights)

*CONVENIENCE PACKAGE (includes in cab LMI light bar)

*"CE" Mark Conformance (includes European boom, battery disconnect switch, 3rd wrap indicator, electric emergency auxiliary steering, dual axis joystick controllers)

*Cross axle differential locks (front and rear)

*Full-length aluminum decking

*Manual pump disconnect

*Pintle hook - rear

*360 degree NYC style positive swinglock

*Rubber mat for stowage trough

*PAT datalogger

*Aluminum fender protectors

**Denotes optional equipment*

RT700E

dimensions

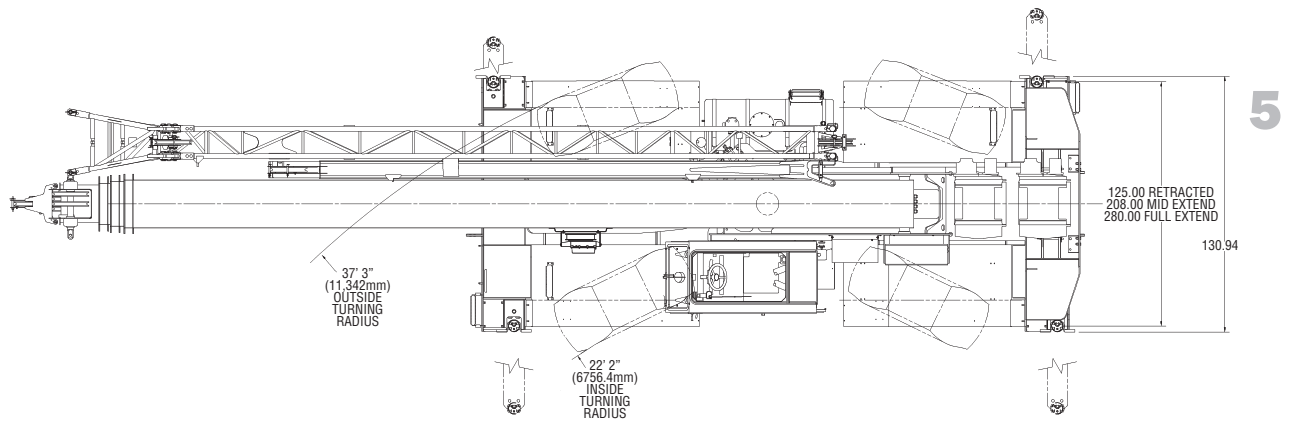

Note: () Reference dimensions in mm

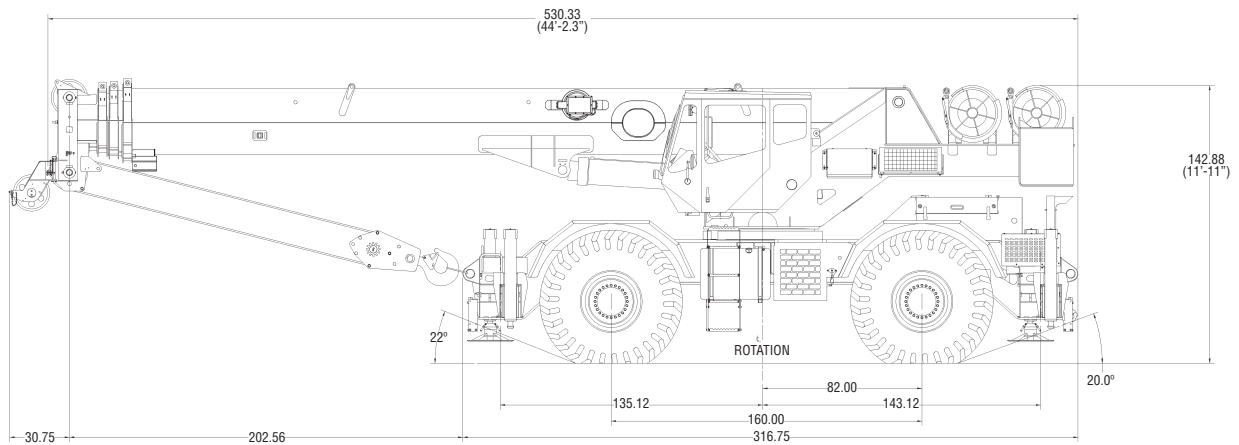

Weights

	GVW		Front		Rear	
	lb.	kg	lb.	kg	lb.	kg
Basic Machine including 110 ft. main boom, main hoist with 500 ft. of wire rope, IPO, full pinned counterweight	85,136	(38 618)	40,813	(18 513)	44,323	(20 105)
ADD: 33 ft.-56 ft. bi-fold swingaway + extension carrier brackets	2,810	(1 275)	4,426	(2 008)	-1,616	(-733)
ADD: 500 ft. of wire rope on auxiliary hoist and auxiliary boom nose	625	(-284)	-230	(-104)	855	(-388)
ADD: Auxiliary boom nose	130	(59)	374	(170)	-244	(-111)
ADD: 50T (45mt) 3-sheave hookblock	1,000	(454)	1 000	(454)	0	(0)
ADD: 60T (55mt) 5-sheave hookblock	1,250	(567)	1,250	(567)	0	(0)
ADD: 8.3T (7.5mt) headache ball	347	(157)	565	(256)	-218	(-99)
ADD: Full aluminum decking	165	(75)	83	(38)	83	(38)
Remove: Hydraulic removal counterweight	-13,320	(-6 042)	4,550	(206)	-17,870	(-8 106)

RT700E

working range

Working range – 110 ft. Main Boom & 33-56 ft. bi-fold swingaway

6

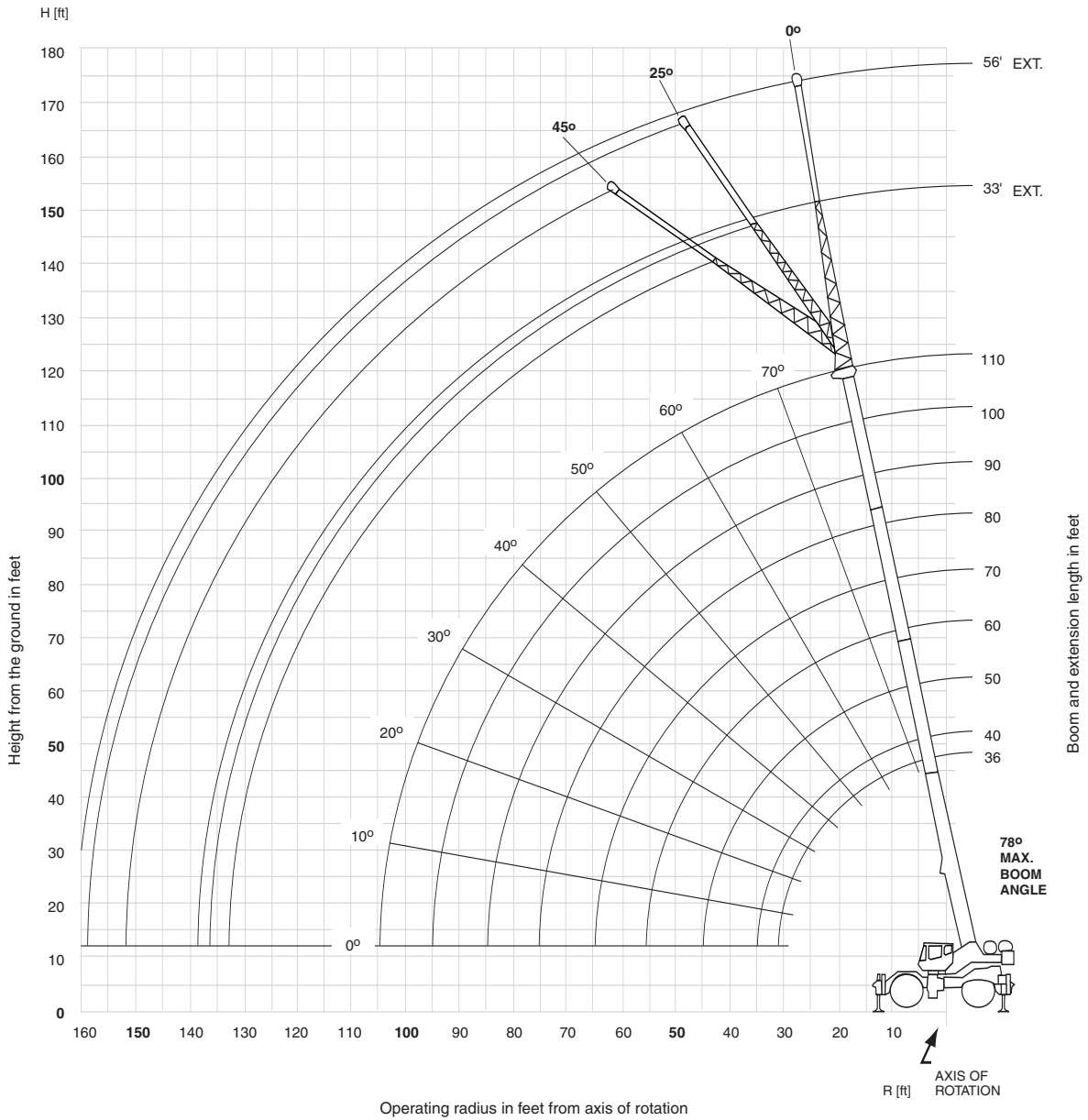

RT700E

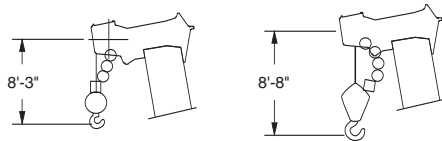

Dimensions are for largest Grove furnished hookblock and headache ball, with anti-two block activated.

THIS CHART IS ONLY A GUIDE AND SHOULD NOT BE USED TO OPERATE THE CRANE. The individual crane's load chart, operating instructions and other instructional plates must be read and understood prior to operating the crane.

GROVE

Courtesy of Crane.Market

RT750E load chart

 36 - 110 ft.
  12,242 lbs
  23 ft. 4 in. spread
  360°

Feet	36	40	50	**60	70	80	90	100	110
10	100,000 (69)	84,400 (72)	80,200 (76)	*62,500 (78)					
12	100,000 (65.5)	84,400 (68.5)	80,200 (73.5)	62,500 (77)	*36,800 (78)				
15	85,400 (59.5)	82,700 (63.5)	80,200 (70)	61,000 (74)	36,800 (76.5)	*36,800 (78)	*31,000 (78)		
20	65,700 (49)	65,000 (55)	64,300 (63.5)	50,650 (69)	36,800 (72)	36,800 (75)	31,000 (77)	*29,100 (78)	*24,000 (78)
25	52,800 (36)	52,450 (45)	51,850 (56.5)	41,800 (63.5)	36,800 (68)	34,000 (71)	30,000 (73.5)	27,000 (76)	24,000 (77.5)
30		42,150 (31.5)	39,600 (48.5)	38,000 (57.5)	33,400 (63)	29,000 (67)	25,300 (70.5)	24,200 (72.5)	22,000 (75)
35			31,750 (40)	29,750 (51.5)	28,700 (58)	25,000 (63)	22,200 (67)	21,750 (69.5)	20,000 (72)
40			24,450 (28)	24,750 (45)	23,600 (53)	22,000 (59)	20,200 (63)	19,000 (66.5)	18,500 (69)
45				19,750 (37)	19,700 (47.5)	18,800 (54.5)	17,800 (59.5)	17,300 (63)	17,300 (66.5)
50				16,000 (26.5)	16,750 (41)	16,500 (49.5)	16,000 (55.5)	16,000 (60)	16,000 (63.5)
55					13,650 (33.5)	14,300 (44.5)	14,100 (51)	14,100 (56.5)	14,100 (60)
60					11,150 (24)	12,000 (38.5)	12,200 (47)	12,200 (52.5)	12,200 (57)
65						10,100 (31.5)	10,800 (42)	10,600 (48.5)	10,600 (53.5)
70						8,480 (22.5)	9,410 (36.5)	9,000 (44.5)	9,000 (50)
75							8,100 (30)	7,800 (40)	7,800 (46.5)
80							6,920 (21.5)	6,600 (34.5)	6,600 (42.5)
85								5,800 (28.5)	5,800 (38)
90								5,000 (20.5)	5,000 (33)
95									4,440 (27.5)
100									3,880 (19.5)
Minimum boom angle (°) for indicated length (no load)									0
Maximum boom length (ft.) at 0° boom angle (no load)									110

NOTE: () Boom angles are in degrees.
 #LMI operating code. Refer to LMI manual for operating instructions.
 *This capacity is based on maximum boom angle.

Lifting Capacities at Zero Degree Boom Angle On Outriggers Fully Extended - 360°

Boom Angle	Main Boom Length in Feet								
	36	40	50	**60	70	80	90	100	110
0°	29,050 (29.8)	24,450 (34.2)	17,050 (44.2)	11,950 (54.6)	9,400 (64.2)	7,310 (74.2)	6,050 (84.2)	4,660 (94.2)	3,350 (104.2)

NOTE: () Reference radii in feet.

** Boom length is with inner-mid fully extended and outer-mid & fly fully retracted.

A6-829-101070

7

RT700E

THIS CHART IS ONLY A GUIDE AND SHOULD NOT BE USED TO OPERATE THE CRANE. The individual crane's load chart, operating instructions and other instructional plates must be read and understood prior to operating the crane.

GROVE

Courtesy of Crane.Market

RT760E load chart

 36 - 110 ft.
  12,242 lbs
  100%
  360°
 23 ft. 4 in. spread

8

Feet	36	40	50	**60	70	80	90	100	110
10	120,000 (69)	84,400 (72)	80,200 (76)	*62,500 (78)					
12	100,000 (65.5)	84,400 (68.5)	80,200 (73.5)	62,500 (77)	*36,800 (78)				
15	85,400 (59.5)	82,700 (63.5)	80,200 (70)	61,000 (74)	36,800 (76.5)	*36,800 (78)	*31,000 (78)		
20	65,700 (49)	65,000 (55)	64,300 (63.5)	50,650 (69)	36,800 (72)	36,800 (75)	31,000 (77)	*29,100 (78)	*24,000 (78)
25	52,800 (36)	52,450 (45)	51,850 (56.5)	41,800 (63.5)	36,800 (68)	34,000 (71)	30,000 (73.5)	27,000 (76)	24,000 (77.5)
30		42,150 (31.5)	39,600 (48.5)	38,000 (57.5)	33,400 (63)	29,000 (67)	25,300 (70.5)	24,200 (72.5)	22,000 (75)
35			31,750 (40)	29,750 (51.5)	28,700 (58)	25,000 (63)	22,200 (67)	21,750 (69.5)	20,000 (72)
40			24,450 (28)	24,750 (45)	23,600 (53)	22,000 (59)	20,200 (63)	19,000 (66.5)	18,500 (69)
45				19,750 (37)	19,700 (47.5)	18,800 (54.5)	17,800 (59.5)	17,300 (63)	17,300 (66.5)
50				16,000 (26.5)	16,750 (41)	16,500 (49.5)	16,000 (55.5)	16,000 (60)	16,000 (63.5)
55					13,650 (33.5)	14,300 (44.5)	14,100 (51)	14,100 (56.5)	14,100 (60)
60					11,150 (24)	12,000 (38.5)	12,200 (47)	12,200 (52.5)	12,200 (57)
65						10,100 (31.5)	10,800 (42)	10,600 (48.5)	10,600 (53.5)
70						8,480 (22.5)	9,410 (36.5)	9,000 (44.5)	9,000 (50)
75							8,100 (30)	7,800 (40)	7,800 (46.5)
80							6,920 (21.5)	6,600 (34.5)	6,600 (42.5)
85								5,800 (28.5)	5,800 (38)
90								5,000 (20.5)	5,000 (33)
95									4,440 (27.5)
100									3,880 (19.5)

Minimum boom angle (°) for indicated length (no load) 0

Maximum boom length (ft.) at 0° boom angle (no load) 110

NOTE: () Boom angles are in degrees.

#LMI operating code. Refer to LMI manual for operating instructions.

*This capacity is based on maximum boom angle.

Lifting Capacities at Zero Degree Boom Angle On Outriggers Fully Extended - 360°

Boom Angle	Main Boom Length in Feet								
	36	40	50	**60	70	80	90	100	110
0°	29,050 (29.8)	24,450 (34.2)	17,050 (44.2)	11,950 (54.6)	9,400 (64.2)	7,310 (74.2)	6,050 (84.2)	4,660 (94.2)	3,350 (104.2)

NOTE: () Reference radii in feet.

** Boom length is with inner-mid fully extended and outer-mid & fly fully retracted.

A6-829-101070

RT700E

THIS CHART IS ONLY A GUIDE AND SHOULD NOT BE USED TO OPERATE THE CRANE. The individual crane's load chart, operating instructions and other instructional plates must be read and understood prior to operating the crane.

GROVE

Courtesy of Crane.Market

RT700E load chart



Pounds						
Feet	33 ft. LENGTH			56 ft. LENGTH		
	0° OFFSET #0021	25° OFFSET #0022	45° OFFSET #0023	0° OFFSET #0041	25° OFFSET #0042	45° OFFSET #0043
30	12,900 (78)					
35	12,900 (76)			*8,330 (78)		
40	12,900 (74)	*10,850 (78)		8,330 (77.5)		
45	12,900 (72)	10,450 (77)	*7,410 (78)	8,330 (76)		
50	12,100 (70)	10,000 (74.5)	7,200 (77.5)	8,330 (74.5)		
55	11,100 (68)	9,220 (72.5)	6,990 (75)	8,250 (73)	*5,300 (78)	
60	10,100 (66)	8,550 (70.5)	6,800 (72.5)	7,540 (71)	5,140 (77)	
65	9,130 (63.5)	7,930 (68)	6,650 (70.5)	7,160 (69)	5,100 (75)	*3,860 (78)
70	8,460 (61.5)	7,380 (65.5)	6,490 (68)	6,820 (67.5)	5,100 (73)	3,790 (77.5)
75	7,840 (59)	6,900 (63)	6,370 (65.5)	6,300 (65.5)	4,800 (71)	3,660 (75)
80	7,230 (56.5)	6,470 (60.5)	6,110 (62.5)	5,810 (63.5)	4,580 (69)	3,550 (73)
85	6,690 (54)	6,070 (58)	5,780 (60)	5,370 (61.5)	4,470 (67.5)	3,450 (71)
90	6,140 (51)	5,720 (55.5)	5,480 (57)	4,980 (59.5)	4,330 (65.5)	3,410 (68.5)
95	5,670 (48.5)	5,400 (52.5)	5,200 (54)	4,630 (57)	4,070 (63)	3,300 (66.5)
100	5,020 (45.5)	5,100 (49.5)	4,950 (51)	4,320 (55)	3,830 (61)	3,260 (64)
105	4,350 (42.5)	4,760 (46.5)	4,650 (47.5)	4,040 (52.5)	3,620 (58.5)	3,220 (62)
110	3,750 (39.5)	4,160 (43)		3,770 (50.5)	3,410 (56)	3,180 (59.5)
115	3,210 (36)	3,600 (39.5)		3,540 (48)	3,230 (53.5)	3,060 (56.5)
120	2,720 (32)	3,100 (35)		3,300 (45.5)	3,050 (51)	2,940 (53.5)
125	2,270 (27.5)	2,640 (30.5)		2,870 (42.5)	2,890 (48.5)	2,800 (50.5)
130	1,860 (22)			2,470 (39.5)	2,730 (45.5)	
135				2,110 (36.5)	2,590 (42.5)	
140				1,770 (33)	2,250 (38.5)	
145				1,460 (29.5)	1,880 (34.5)	
150				1,170 (25)		
Minimum boom angle (°) for indicated length (no load)	21	25	45	25	28	45
Maximum boom length (ft.) at 0° boom angle (no load)		100			90	

NOTE: () Boom angles are in degrees. A6-829-101289
 #LMI operating code. Refer to LMI manual for operating instructions.
 *This capacity is based upon maximum boom angle.

- NOTES:**
- All capacities above the bold line are based on structural strength of boom extension and do not exceed 85% of tipping loads, in accordance with SAE J-765.
 - 33 ft. and 56 ft. boom extension lengths may be used for single line lifting service.
 - Radii listed are for a fully extended boom with the boom extension erected. For main boom lengths less than fully extended, the rated loads are determined by boom angle. Use only the column which corresponds to the boom extension length and offset for which the machine is configured. For boom angles not shown, use the rating of the next lower boom angle.
WARNING: Operation of this machine with heavier loads than the capacities listed is strictly prohibited. Machine tipping with boom extension occurs rapidly and without advance warning.
 - Boom angle is the angle above or below horizontal of the longitudinal axis of the boom base section after lifting rated load.
 - Capacities listed are with outriggers fully extended and vertical jacks set only.

RT700E

THIS CHART IS ONLY A GUIDE AND SHOULD NOT BE USED TO OPERATE THE CRANE. The individual crane's load chart, operating instructions and other instructional plates must be read and understood prior to operating the crane.

working range

Working range – 110 ft. Main Boom, Bi-Fold Swingaway & 20 ft. & 40 ft. Inserts

10

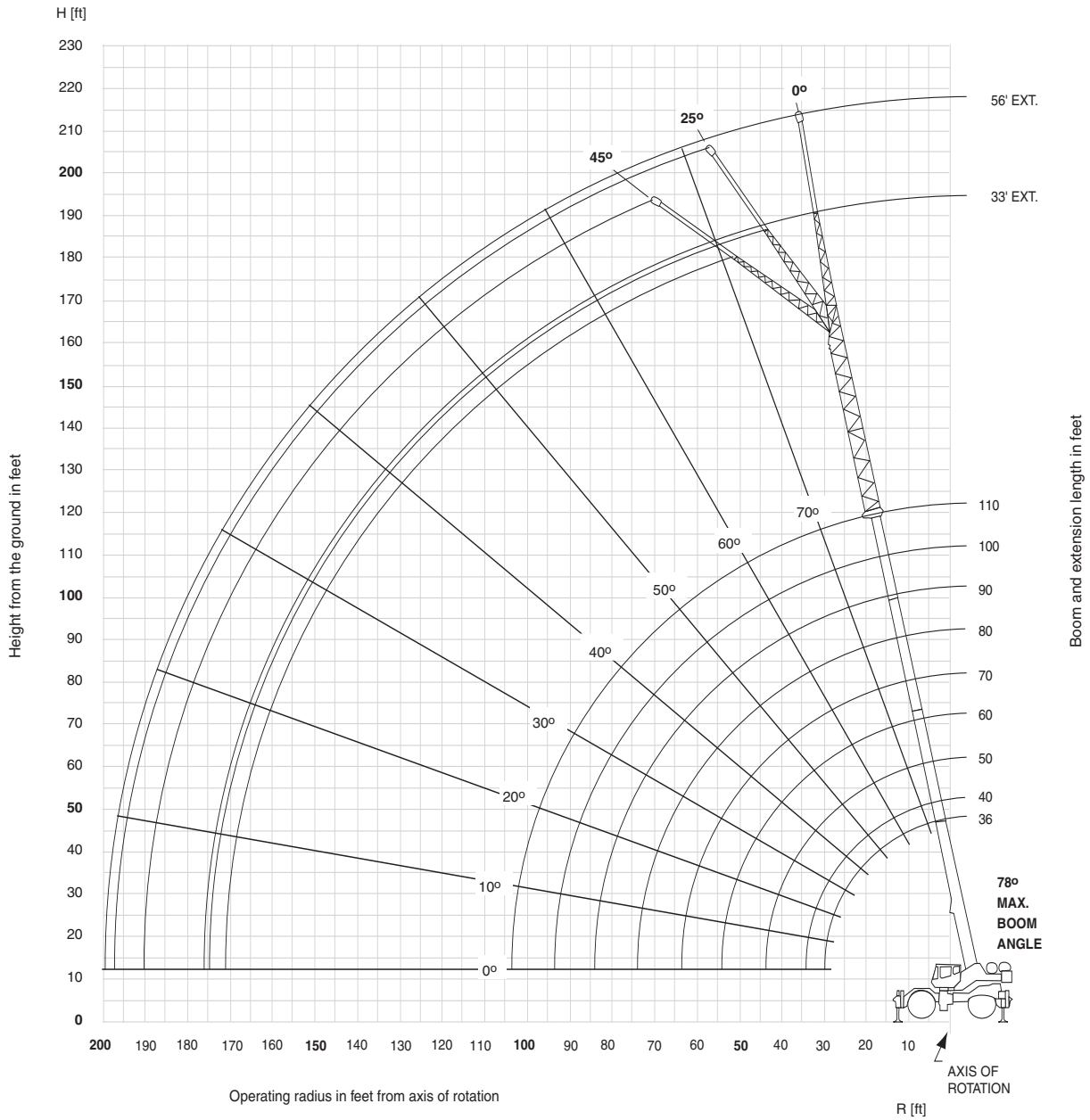

RT700E

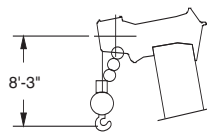

Dimensions are for largest Grove furnished hookblock and headache ball, with anti-two block activated.

THIS CHART IS ONLY A GUIDE AND SHOULD NOT BE USED TO OPERATE THE CRANE. The individual crane's load chart, operating instructions and other instructional plates must be read and understood prior to operating the crane.

GROVE

Courtesy of Crane.Market

RT700E load chart

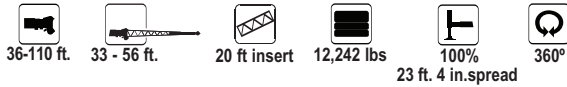

Pounds						
Feet	33 ft. LENGTH			56 ft. LENGTH		
	0° OFFSET #0064	25° OFFSET #0065	45° OFFSET #0066	0° OFFSET #0084	25° OFFSET #0085	45° OFFSET #0086
35	*9,360 (78)					
40	9,360 (77)			*6,300 (78)		
45	8,480 (75.5)	*7,480 (78)		6,300 (77.5)		
50	7,680 (73.5)	7,070 (77.5)	*5,880 (78)	6,000 (76.5)		
55	6,990 (71.5)	6,470 (76)	5,880 (77.5)	5,990 (75)		
60	6,390 (70)	5,970 (74)	5,480 (76.5)	5,980 (73.5)	*4,840 (78)	
65	5,890 (68)	5,570 (72)	5,080 (74.5)	5,510 (72)	4,840 (77.5)	
70	5,390 (66)	5,070 (70)	4,780 (72.5)	5,010 (70)	4,440 (76.5)	
75	4,990 (64)	4,770 (68)	4,480 (70.5)	4,560 (68.5)	4,050 (74.5)	*3,760 (78)
80	4,650 (62)	4,400 (66)	4,190 (68.5)	4,170 (67)	3,870 (73)	3,460 (76.5)
85	4,300 (60)	4,150 (64)	3,890 (66)	3,820 (65)	3,570 (71)	3,260 (74.5)
90	4,000 (58)	3,850 (62)	3,690 (64)	3,520 (63.5)	3,320 (69.5)	2,960 (73)
95	3,760 (55.5)	3,650 (59.5)	3,500 (61.5)	3,220 (61.5)	3,070 (67.5)	2,770 (71)
100	3,510 (53.5)	3,410 (57.5)	3,300 (59.5)	2,980 (60)	2,880 (66)	2,570 (69)
105	3,260 (51)	3,210 (55)	3,100 (57)	2,780 (58)	2,680 (64)	2,460 (67)
110	3,070 (48.5)	3,020 (52.5)	2,930 (54.5)	2,530 (56)	2,480 (62)	2,340 (65)
115	2,870 (46)	2,870 (50)	2,780 (51.5)	2,340 (54)	2,280 (60)	2,200 (63)
120	2,730 (43.5)	2,730 (47)		2,190 (52)	2,140 (58)	2,050 (60.5)
125	2,530 (40.5)	2,580 (44)		2,000 (50)	1,990 (55.5)	1,910 (58.5)
130	2,210 (37.5)	2,440 (41)		1,850 (48)	1,850 (53.5)	1,810 (56)
135	1,850 (34.5)	2,150 (37.5)		1,720 (45.5)	1,750 (51)	1,670 (53.5)
140	1,510 (30.5)	1,750 (34)		1,610 (43)	1,610 (48.5)	
145	1,200 (26.5)				1,520 (46)	
150					1,370 (43)	
Minimum boom angle (°) for indicated length (no load)	20	25	45	40	41	45
Maximum boom length (ft.) at 0° boom angle (no load)		90		70		

NOTE: () Boom angles are in degrees. A6-829-101371A
 #LMI operating code. Refer to LMI manual for operating instructions.
 *This capacity is based upon maximum boom angle.

NOTES:

- All capacities above the bold line are based on structural strength of boom extension and do not exceed 85% of tipping loads, in accordance with SAE J-765.
- 33 ft. and 56 ft. boom extension lengths may be used for single line lifting service only.
- For main boom lengths less than 110 ft. with the boom extension erected, the rated loads are determined by boom angle. Use only the column which corresponds to the boom extension length and offset for which the machine is set up. For boom angles not shown, use rating of the next lower boom angle.
- WARNING:** Operation of this machine with heavier loads than the capacities listed is strictly prohibited. Machine tipping with boom extension occurs rapidly and without advance warning.
- Boom angle is the angle above or below horizontal of the longitudinal axis of the boom base section after lifting rated load.
- Capacities listed are with outriggers fully extended and vertical jacks set only.

load chart

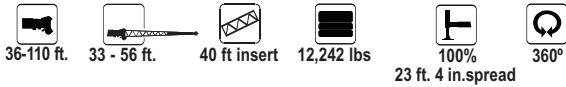

12

		Pounds					
		33 ft. LENGTH			56 ft. LENGTH		
Feet	0° OFFSET #0064	25° OFFSET #0065	45° OFFSET #0066	0° OFFSET #0084	25° OFFSET #0085	45° OFFSET #0086	360°
50	5,960 (76)			4,510 (78)			
55	5,360 (74.5)	5,860 (78)		4,210 (77.5)			
60	4,860 (73)	5,260 (76.5)	*5,170 (78)	3,910 (76)			
65	4,370 (71)	4,870 (75)	4,670 (77.5)	3,710 (74.5)			
70	3,970 (69.5)	4,370 (73)	4,270 (75.5)	3,410 (73)	*3,710 (78)		
75	3,670 (67.5)	4,070 (71.5)	3,980 (73.5)	3,220 (71.5)	3,420 (77.5)		
80	3,270 (66)	3,670 (69.5)	3,680 (72)	2,820 (70)	3,120 (76)		
85	2,980 (64)	3,370 (68)	3,380 (70)	2,520 (68.5)	2,820 (74.5)	2,730 (77.5)	
90	2,780 (62.5)	3,080 (66)	3,080 (68)	2,320 (66.5)	2,620 (72.5)	2,530 (76)	
95	2,480 (60.5)	2,880 (64)	2,890 (66)	2,030 (65)	2,330 (71)	2,340 (74.5)	
100	2,290 (58.5)	2,580 (62)	2,690 (64)	1,830 (63.5)	2,130 (69.5)	2,140 (72.5)	
105	2,090 (56.5)	2,390 (60)	2,390 (62)	1,630 (62)	1,930 (68)	1,940 (71)	
110	1,900 (54.5)	2,190 (58)	2,200 (60)	1,440 (60)	1,730 (66)	1,740 (69)	
115	1,700 (52.5)	2,000 (56)	2,100 (58)	1,240 (58.5)	1,540 (64.5)	1,550 (67)	
120	1,600 (50.5)	1,800 (54)	1,910 (55.5)	1,140 (57)	1,340 (62.5)	1,450 (65)	
125	1,410 (48)	1,700 (51.5)	1,710 (53)		1,240 (61)	1,260 (63.5)	
130	1,310 (46)	1,510 (49.5)	1,520 (50.5)		1,050 (59)	1,160 (61.5)	
135	1,120 (43.5)	1,420 (47)	1,420 (48)				
140	1,030 (41)	1,220 (44.5)					
145		1,130 (41.5)					
150		1,040 (38.5)					
No Load Stability Data							
Min. boom angle at 110' boom length	37°	37°	45°	54°	56°	58°	
Max. boom length at 0° boom angle	70 ft.			40 ft.			

NOTE: () Boom angles are in degrees. A6-829-101581

*This capacity is based upon maximum boom angle.

#LMI operating code. Refer to LMI manual for instructions.

NOTES:

- All capacities above the bold line are based on structural strength of boom extension and do not exceed 85% of tipping loads, in accordance with SAE J-765.
- 33 ft. and 56 ft. boom extension lengths may be used for single line lifting service only.
- For main boom lengths less than 110 ft. with the boom extension erected, the rated loads are determined by boom angle. Use only the column which corresponds to the boom extension length and offset for which the machine is set up. For boom angles not shown, use rating of the next lower boom angle.
- WARNING:** Operation of this machine with heavier loads than the capacities listed is strictly prohibited. Machine tipping with boom extension occurs rapidly and without advance warning.
- Boom angle is the angle above or below horizontal of the longitudinal axis of the boom base section after lifting rated load.
- Capacities listed are with outriggers fully extended and vertical jacks set only.

RT700E

THIS CHART IS ONLY A GUIDE AND SHOULD NOT BE USED TO OPERATE THE CRANE. The individual crane's load chart, operating instructions and other instructional plates must be read and understood prior to operating the crane.

GROVE

Courtesy of Crane.Market

RT700E load charts



36-70 ft.



12,242 lbs



Stationary



360°



36-70 ft.



12,242 lbs



Stationary



Defined Arc
Over Front

Pounds					
#9005					
Feet	Main Boom Length in Feet				
	36	40	50	*60	70
10	45,300 (69)	39,700 (72)			
12	41,750 (65.5)	39,700 (68.5)	29,600 (73.5)		
15	29,350 (59.5)	26,450 (63.5)	26,450 (70)	20,900 (74)	
20	17,800 (49)	17,850 (55)	17,050 (63.5)	16,250 (69)	16,250 (72)
25	11,750 (36)	11,700 (45)	11,350 (56.5)	10,850 (63.5)	10,850 (68)
30		8,040 (31.5)	7,820 (48.5)	7,470 (57.5)	7,470 (63)
35			5,400 (40)	5,120 (51.5)	5,120 (58)
40				3,660 (28)	3,200 (45)
45					1,000 (37)
50					1,150 (41.0)
Lifting Capacities at Zero Degree Boom Angle On Rubber - Stationary 360					
Boom Angle	Main Boom Length in Feet				
	36	40	50		
0°	8,180 (29.7)	5,890 (34.2)	2,170 (44.2)		

Note: () Reference radii in feet.

A6-829-101048A

#LMI operating code. Refer to LMI manual for instructions.

*60 ft. boom length is with inner-mid extended and outer-mid & fly retracted.

Pounds					
#9005					
Feet	Main Boom Length in Feet				
	36	40	50	*60	70
10	45,300 (69)	42,850 (72)	29,600 (76)		
12	43,650 (65.5)	41,350 (68.5)	29,600 (73.5)		
15	38,300 (59.5)	36,300 (63.5)	29,600 (70)	20,900 (74)	17,300 (76.5)
20	31,150 (49)	29,550 (55)	25,900 (63.5)	20,900 (69)	17,300 (72)
25	24,100 (36)	24,150 (45)	21,800 (56.5)	18,800 (63.5)	17,300 (68)
30		17,400 (31.5)	17,200 (48.5)	15,300 (57.5)	15,300 (63)
35			12,800 (40)	12,500 (51.5)	11,000 (58)
40				9,720 (28)	9,390 (45)
45					7,090 (37)
50					5,310 (26.5)
55					3,870 (33.5)
60					3,170 (24)
Lifting Capacities at Zero Degree Boom Angle On Rubber - Defined Arc Over Front					
Boom Angle	Main Boom Length in Feet				
	36	40	50	*60	70
0°	17,600 (29.7)	13,600 (34.2)	7,750 (44.2)	4,010 (54.6)	2,670 (64.2)

Note: () Reference radii in feet.

A6-829-101047

#LMI operating code. Refer to LMI manual for instructions.

*60 ft. boom length is with inner-mid extended and outer-mid & fly retracted.

13

RT700E

load charts

14

**RIGGING CHART
INSTALLATION AND REMOVAL OF
12,000 LB. COUNTERWEIGHT**

ON OUTRIGGERS FULLY EXTENDED - 3600



#0801

Feet	Main Boom Length in Feet	
	*36	40
10	18,000 (69)	18,000 (72)
12	18,000 (65.5)	18,000 (68.5)
15	18,000 (59.5)	18,000 (63.5)
20	18,000 (49)	18,000 (55)
25	18,000 (36)	18,000 (45)
30		18,000 (31.5)

NOTE: () Boom angles are in degrees.
#LMI operating code. Refer to LMI manual for
operating instructions.

Boom Angle	Main Boom Length in Feet	
	*36	40
0°	18,000 (29.8)	18,000 (34.2)

A6-829-102134

NOTE: () Reference radii in feet.
*Boom must be fully retracted.

NOTES

RT700E

GROVE

load handling

15

Weight Reductions for Load Handling Devices

33 FT. - 56 FT. FOLDING BOOM EXTENSION

*33 ft. Extension (Erected) -	5,080 lb.
*56 ft. Extension (Erected) -	11,330 lb.

FOLDING EXT. WITH 20 FT. INSERT

*33 ft. Extension (Erected) -	11,248 lb.
*56 ft. Extension (Erected) -	19,372 lb.

FOLDING EXT. WITH 40 FT. INSERT

*33 ft. Extension (Erected) -	19,671 lb.
*56 ft. Extension (Erected) -	29,671 lb.

*Reduction of main boom capacities
(no deduct required for stowed boom extension)

When lifting over swingaway and/or jib combinations, deduct total weight of all load handling devices reeved over main boom nose directly from swingaway or jib capacity.

NOTE: All load handling devices and boom attachments are considered part of the load and suitable allowances MUST BE MADE for their combined weights. Weights are for Grove furnished equipment.

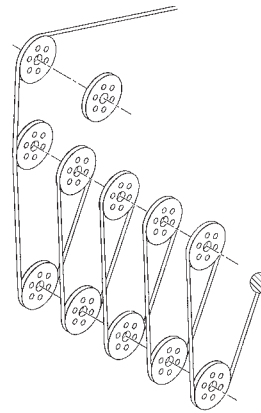

Line Pulls and Reeving Information

AUXILIARY BOOM NOSE	137 lb.
HOOKBLOCKS and HEADACHE BALLS:	
60 Ton, 5 Sheave	1250 lb.+
50 Ton, 4 Sheave	1000 lb.+
50 Ton, 3 Sheave	1000 lb.+
8.3 Ton Headache Ball (non-swivel)	350 lb.+
8.3 Ton Headache Ball (swivel)	370 lb.+

+Refer to rating plate for actual weight.

Line Pulls and Reeving Information

Hoists	Cable Specs	Permissible Line Pulls	Nominal Cable Length
Main	3/4" (19 mm) 6x37 Class, EIPS, IWRC Special Flexible Min. Breaking Str. 58,800 lb.	16,800 lb.	500 ft.
Main & Aux.	3/4" (19 mm) Flex-X 35 Rotation Resistant (non-rotating) Min. Breaking Strength 85,800 lb.	16,800 lb.	500 ft.

The approximate weight of 3/4" wire rope is 1.5 lb./ft.

Hoist Performance

Wire Rope Layer	Hoist Line Pulls Two Speed Hoist		Drum Rope Capacity (ft.)			
	Low Available lb.*	High Available lb.*	16 in. Drum Layer	Total	26 in. Drum Layer	Total
1	18,134	9,067	78	78	132	132
2	16,668	8,334	85	164	144	276
3	15,420	7,710	92	256	156	432
4	14,347	7,174	99	356	167	599
5	13,413	6,707	106	462	179	778
6	12,594	6,297	113	575	190	968

*Max. lifting capacity: 6x37 or 35x7 class = 16,800 lb.

Working Area Diagram

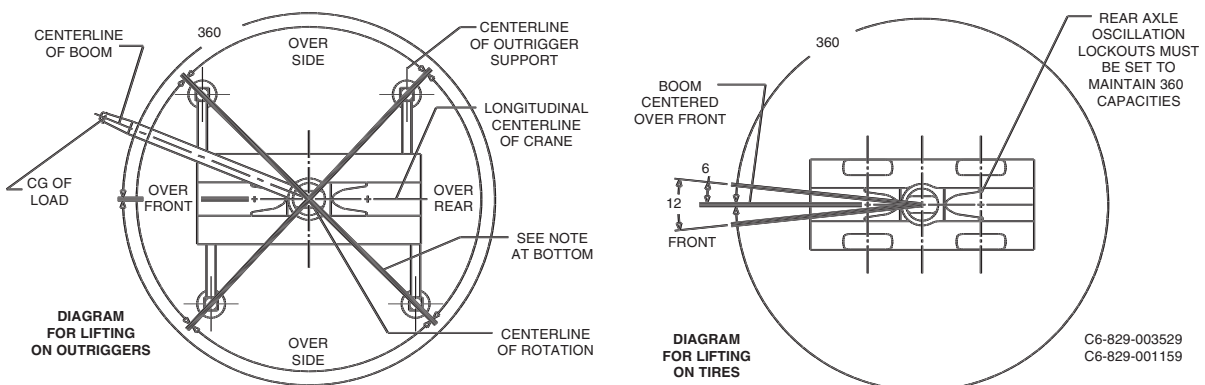

Bold lines determine the limiting position of any load for operation within working areas indicated.

THIS CHART IS ONLY A GUIDE AND SHOULD NOT BE USED TO OPERATE THE CRANE. The individual crane's load chart, operating instructions and other instructional plates must be read and understood prior to operating the crane.

RT700E

GROVE

Courtesy of Crane.Market

Regional Headquarters

Americas

Manitowoc, Wisconsin, USA

Tel: +1 920 684 6621

Fax: +1 920 683 6278

Shady Grove, Pennsylvania, USA

Tel: +1 717 597 8121

Fax: +1 717 597 4062

Regional Offices

Americas

Brazil

Alphaville

Tel: +55 11 3103 0200

Fax: +55 11 4688 2013

Mexico

Monterrey

Tel: +52 81 8124 0128

Fax: +52 81 8124 0129

Europe, Middle East, Africa

Algeria

Hydra

Tel: +21 3 21 48 1173

Fax: +21 3 21 48 1454

Czech Republic

Netvorice

Tel: +420 317 78 9313

Fax: +420 317 78 9314

France

Baudemont

Tel: +33 385 28 2589

Fax: +33 385 28 0430

Cergy

Tel: +33 130 31 3150

Fax: +33 130 38 6085

Decines

Tel: +33 472 81 5000

Fax: +33 472 81 5010

Germany

Langenfeld

Tel: +49 21 73 8909-0

Fax: +49 21 73 8909 30

Hungary

Budapest

Tel: +36 13 39 8622

Fax: +36 13 39 8622

Italy

Parabiago

Tel: +390 331 49 3311

Fax: +390 331 49 3330

Europe, Middle East, Africa

Ecully, France

Tel: +33 472 18 2020

Fax: +33 472 18 2000

Netherlands

Breda

Tel: +31 76 578 3999

Fax: +31 76 578 3978

Poland

Warsaw

Tel: +48 22 843 3824

Fax: +48 22 843 3471

Portugal

Alfena

Tel: +351 229 69 8840

Fax: +351 229 69 8848

Lisbon

Tel: +351 212 109 340

Fax: +351 212 109 349

Russia

Moscow

Tel: +7 495 641 2359

Fax: +7 495 641 2358

U.A.E.

Dubai

Tel: +971 4 3381 861

Fax: +971 4 3382 343

U. K.

Middlesex

Tel: +44 1 895 43 0053

Fax: +44 1 895 45 9500

Sunderland

Tel: +44 191 522 2000

Fax: +44 191 522 2052

Asia – Pacific

Australia

Melbourne

Tel: +61 3 9 336 1300

Fax: +61 3 9 336 1322

Sydney

Tel: +61 2 9 896 4433

Fax: +61 2 9 896 3122

Asia – Pacific

Shanghai, China

Tel: +86 21 51113579

Fax: +86 21 51113578

Singapore

Tel: +65 6264 1188

Fax: +65 6862 4142

China

Beijing

Tel: +86 10 58674761

Fax: +86 10 58674760

Xi'an

Tel: +86 29 87891465

Fax: +86 29 87884504

Korea

Seoul

Tel: +82 2 3439 0400

Fax: +82 2 3439 0405

Philippines

Makati City

Tel: +63 2 844 9437

Fax: +63 2 844 4712

Factories

Brazil

Alphaville

China

Zhangjiagang

France

Charlieu

La Clayette

Moulins

Germany

Wilhelmshaven

India

Calcutta

Pune

Italy

Niella Tanaro

Portugal

Baltar

Fânzeres

Slovakia

Saris

U.S.A.

Manitowoc

Port Washington

Shady Grove



Constant improvement and engineering progress make it necessary that we reserve the right to make specification, equipment and price changes without notice. Illustrations shown may include optional equipment and accessories, and may not include all standard equipment.