

GMK 5110B

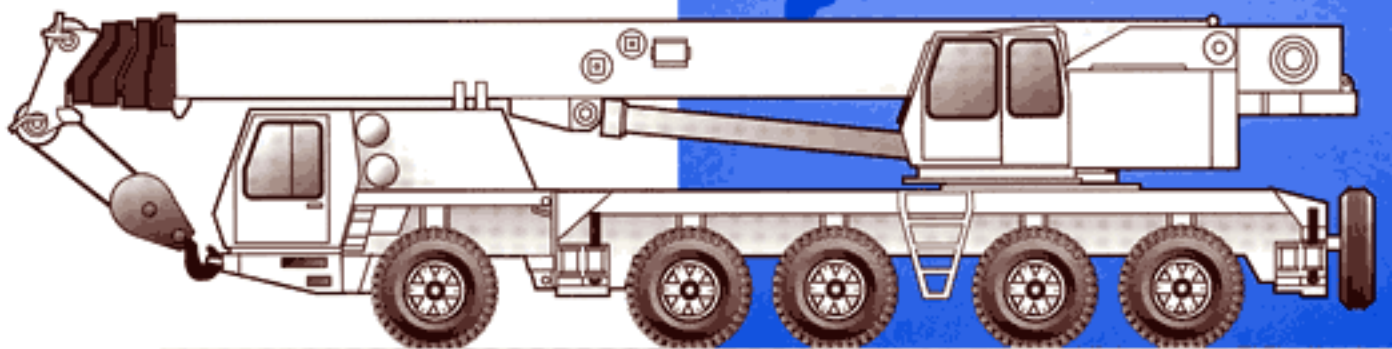

All Terrain Hydraulic Crane

Dimensions

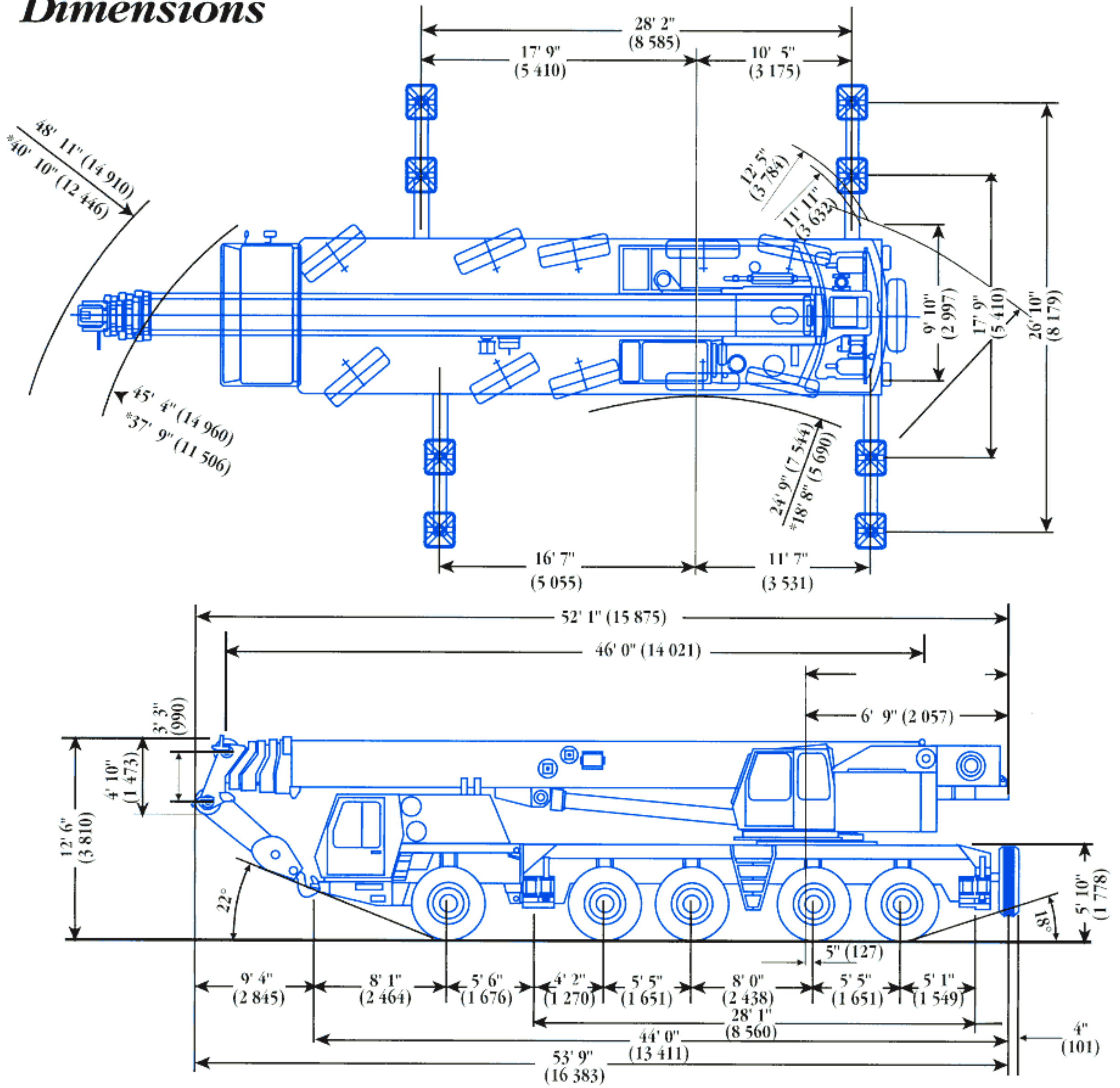

Model GMK 5110B equipped with:

10 X 6 X 10 drive/steer, 14.00R25 tires, hydraulic oil cooler, main hoist with cable (less all counterweight, hook blocks, outrigger floats and lattice extension).

	Crane Axles 1, 2 & 3	Crane Axles 4 & 5	Total
--	-------------------------	----------------------	-------

	82,500 lbs. (3 X 27,500)	33,000 lbs. (2 X 16,500)	115,500 lbs.
--	-----------------------------	-----------------------------	--------------

Weights for accessory equipment:

1. Outrigger floats stowed	+ 140	+ 260	+ 400
2. Brackets for lattice extension to stow on base boom	+ 460	- 110	+ 350
3. Lattice extension - 33/53 ft.	+ 3,500	- 875	+ 2,625
4. 10 X 8 drive	+ 135	+ 735	+ 870
5. Rooster sheave	+ 375	- 195	+ 180
6. 16.00R25 tires in lieu of 14.00R25	+ 1,590	+ 1,060	+ 2,650
7. 20.5R25 tires in lieu of 14.00R25	+ 1,920	+ 1,280	+ 3,200
8. Bracket for spare tire	- 30	+ 85	+ 55
9. Spare tire - 14.00R25	- 300	+ 840	+ 540
10. Spare tire - 16.00R25	- 420	+ 1,150	+ 730
11. Spare tire - 20.5R25	- 490	+ 1,340	+ 850
12. Auxiliary hoist	- 1,500	+ 4,200	+ 2,700
13. Remove rear outrigger beams/jacks	+ 2,395	- 7,795	- 5,400
14. Remove front outrigger beams/jacks	- 5,165	+ 705	- 4,460

Working Range



46-151 ft.
(14.0-46.0m)

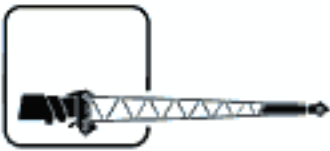

33-53 ft.
(10.0-16.2m)



360°

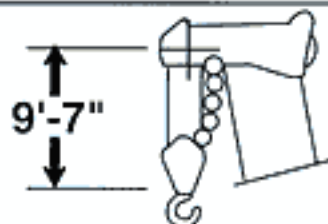
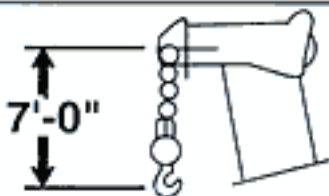
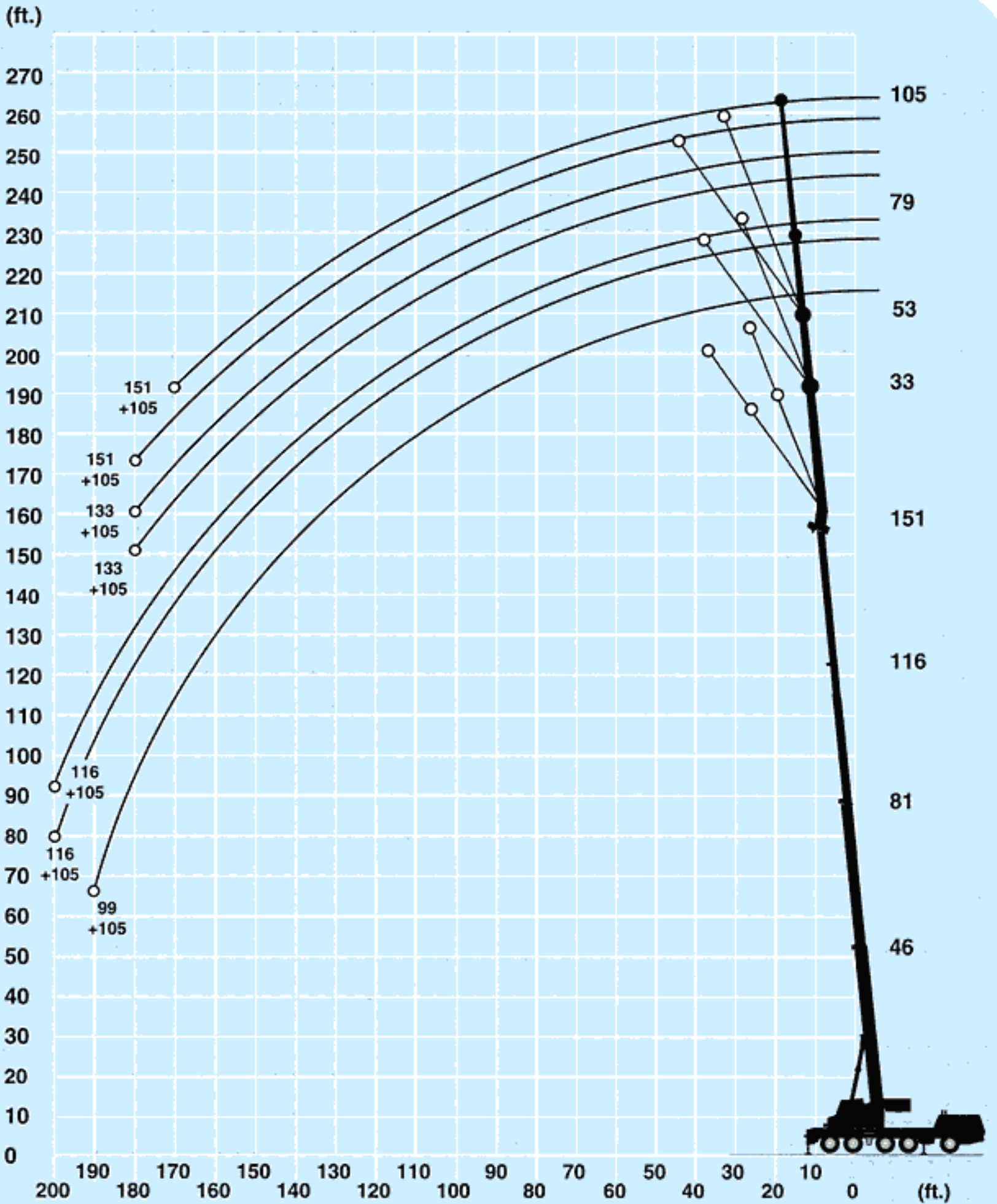

DIMENSIONS ARE FOR LARGEST GROVE FURNISHED HOOK BLOCK AND HEADACHE BALL, WITH ANTI-TWO BLOCK ACTIVATED.

Superstructure specifications

Boom

46 ft. to 151 ft. (14.0 m to 46.0 m) four-section full power boom. Maximum tip height: 161 ft. (49.0 m)

Lattice Extension

Two-stage, 33 ft. to 53 ft. (10.0 m to 16.2 m) lattice extension offsettable at 16° and 30°. Stows alongside base boom section. Maximum tip height: 213 ft. (65.0 m)

*Optional Lattice Extension

53 ft. (16.2 m) base section combines with two 26 ft. (7.92 m) inserts for lengths of 79 and 105 ft. (24.0 and 32.0 m). Both lengths offset at 16° and 30°. Maximum tip height: 264 ft. (80.5 m)

Boom Elevation

Single cylinder with integral holding valves provides elevation from -3° to 84°.

Load Moment & Anti-Two Block System

Load moment and anti-two block system with audio-visual warning and control lever lock-out. These systems provide electronic display of boom angle, length, radius, tip height, relative load moment, maximum permissible load, load indication and warning of impending two-block condition.

Cab

Full vision *aluminum* cab, mounted on left-hand side of turntable, safety glass windows, hinged skylight window with windshield wiper, door with sliding windows, sun visor and roller blind, tinted skylight window pane, engine hot water heater, fan and defroster. Seat with hydraulic suspension and neck support, adjustable control desk and armrest. Ergonomically arranged instrumentation and operating controls for crane and engine.

Swing

Vane motor with planetary gear and holding brake. Swing speed infinitely variable from 0 to 1.5 RPM.

Counterweight

Two 18,500 lbs. (8,392 kg) sections and one 9,300 lbs. (4,218 kg) section for a total of 46,300 lbs. (21,001 kg). Hydraulic installation/removal of all counterweight pieces. Cylinders for counterweight assembly at the turntable.

Engine

Mercedes Benz OM 366 A diesel, 6 cylinders, water-cooled, 141 hp (105 kW) @ 1800 RPM. Maximum torque: 427 ft./lbs. @ 1,500-1,600 RPM.

Fuel Tank Capacity

50 gallons (189 L).

HYDRAULIC SYSTEM

Three separate circuits in open circuit arrangement, comprising one axial piston variable displacement double pump with cumulative flow control and one triple fixed displacement gear pump. Hydraulic oil cooler.

Control System

All crane movements infinitely variable by hydraulic pilot control through armrest-integrated crane control levers with automatic reset to zero.

HOIST SPECIFICATIONS

Main Hoist

Axial piston motor with planetary gear and automatic multiple disk brake. Drum rotation indicator.

Single line pull:	15,000 lbs. (6,804 kg)
Single line speed:	394 FPM (120 m/min)
Rope diameter:	3/4 in. (19 mm)
Rope length:	790 ft. (240 m)

*Optional Auxiliary Hoist

Axial piston motor with planetary gear and automatic multiple disk brake. Drum rotation indicator.

Single line pull:	15,000 lbs. (6,804 kg)
Single line speed:	394 FPM (120 m/min)
Rope diameter:	3/4 in. (19 mm)
Rope length:	590 ft. (180 m)

**Denotes optional equipment.*

Carrier specifications

Chassis

Five-axle, all-welded torsion-resistant box-type construction of high strength steel.

Outriggers

Four hydraulically telescoping beam outriggers with vertical cylinders and outrigger pads. Independent horizontal and vertical movement control on each side of chassis. Crane level indicators for leveling control.

Engine

Mercedes Benz OM 442 LA diesel, 8 cylinders, water-cooled, 503 hp (375 kW) @ 2,100 RPM. Maximum torque: 1,488 ft./lbs. @ 1,100 - 1,600 RPM

Fuel Tank Capacity

100 gallons (378 L).

Transmission

Allison automatic transmission CLBT 755, with two drive programs, each with 5 forward and 1 reverse gear.

Transfer Case

Kessler VG 1800, 2 speed, with longitudinal differential lock.

Drive

10 x 6 x 10

Axles

1st axle line - steer.
2nd axle line - drive/steer.
3rd axle line - drive/steer.
4th axle line - steer (off road only).
5th axle line - drive/steer.

Transverse Differential Locks

Integrated in all center-mounted gearings including shift cylinder.

Interaxle Differential Lock

Integrated with the transfer case.

Suspension

Exclusive "MEGA TRACK" independent hydropneumatic suspension and hydraulic axle lock-out. Suspension range: +6.5 in. (165 mm) to -5.5 in. (-139 mm). Automatic suspension level control by proximity switches.

Tires

10 - 20.5 x 25 radials.

Steering

Dual-circuit hydraulic power-assisted steering. Automatic switch-in of stand-by steering pump in case of main pump failure. Automatic lubrication of steering system with interval control.

Brakes

Service brake: pneumatic dual circuit acting on all wheels. Air dryer.

Parking brake: pneumatically operated spring-loaded brake acting on 2nd, 3rd, 4th and 5th axle line.

Auxiliary brake: hydraulic retarder integrated with automatic transmission.

Cab

Aluminum, two-man design, safety glass, laminated front windshield, windshield wipers, electric windshield washer, defroster nozzle, lockable doors with sliding windows, driver's seat with hydraulic suspension, engine hot water heater, heatable rear view mirrors. Complete operating and driving controls. Stereo radio/cassette. *Cab can be tilted forward by 60°* for easy access to engine, transmission, hydraulic pumps, heater and batteries.

Electrical System

24 V lighting system and signals. Generator: 28 V / 55 A. Two batteries: 12 V / 170 Ah each.

Lights

Full lighting package (includes head, rear, stop, rear fog, reverse, hazard, directional indicators and reflectors). Halogen work lamp, two rotating beacons.

Maximum Speed

45 mph (72 kph)

Maximum Gradeability

52% (theoretical)

Gross Vehicle Weight (Approximate)

Basic unit 115,500 lbs. (52 391 kg)

Miscellaneous Standard Equipment

Hydraulic oil cooler; spare tire and wheel - with carry bracket; amber warning light; working light; tool kit, wheel chocks, fire extinguisher; boom float kit for boom dolly operation (less dolly) with air and electric connection at rear of carrier; quick disconnect fittings for removal of outrigger beams and jacks.

Optional Equipment

- * 10 x 8 drive
- * Hookblocks and headache balls
- * 14.00R25 radial tires in lieu of standard
- * 16.00R25 radial tires in lieu of standard
- * Rooster sheave
- * Auxiliary hoist
- * 2 x 26 ft. inserts for lattice extension



46 -151 ft.
(14.0-46.0 m)



46,300 lbs.
(21 002 kg)



360°

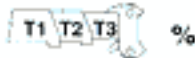

T1	0.00	0.50/0.00	1.00/0.50/0.00	1.00/0.50/0.00	1.00/0.50/0.00	1.00/0.50	1.00
T2	0.00	0.00/0.25	0.00/0.25/0.50	0.25/0.50/0.75	0.50/0.75/1.00	0.75/1.00	1.00
T3	0.00	0.00/0.25	0.00/0.25/0.50	0.25/0.50/0.75	0.50/0.75/1.00	0.75/1.00	1.00



85% Domestic (Pounds)

(Feet)	46	64	81	99	116	133	151
10.00	220,000	198,000	136,000				
15.00	163,000	154,000	132,000	85,000			
20.00	123,000	120,000	111,000	85,000	72,000	53,000	41,200
25.00	95,000	93,000	91,000	85,000	68,000	53,000	41,200
30.00	77,000	79,000	77,000	75,000	65,000	53,000	41,200
35.00	63,000	66,000	63,000	62,000	60,000	53,000	41,200
40.00		56,000	53,000	55,000	53,000	51,000	41,200
45.00		48,000	48,000	47,000	47,000	46,000	39,400
50.00		41,800	42,800	40,800	41,600	40,400	37,000
55.00			37,800	35,800	36,600	35,400	34,800
60.00			33,600	33,000	32,400	31,200	31,800
65.00			30,000	30,600	28,600	28,600	28,000
70.00			26,200	27,000	24,800	25,800	24,200
75.00				23,800	22,600	22,600	21,000
80.00				21,000	21,200	19,800	18,200
85.00				18,600	19,200	17,400	15,800
90.00					17,200	15,400	13,800
95.00					15,200	13,600	12,000
100.00					13,600	12,000	10,600
105.00						10,600	9,000
110.00						9,400	7,800
115.00						8,200	6,600
120.00						7,200	5,600
125.00							4,800
130.00							3,800
135.00							3,000



46 -151 ft.
(14.0-46.0 m)



27,800 lbs.
(12 6110 kg)



360°

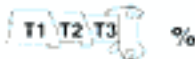

T1	0.00	0.50/0.00	1.00/0.50/0.00	1.00/0.50/0.00	1.00/0.50/0.00	1.00/0.50	1.00
T2	0.00	0.00/0.25	0.00/0.25/0.50	0.25/0.50/0.75	0.50/0.75/1.00	0.75/1.00	1.00
T3	0.00	0.00/0.25	0.00/0.25/0.50	0.25/0.50/0.75	0.50/0.75/1.00	0.75/1.00	1.00



85% Domestic (Pounds)

(Feet)	46	64	81	99	116	133	151
10.00	220,000	198,000	136,000				
15.00	160,000	154,000	132,000	85,000			
20.00	115,000	112,000	110,000	85,000	72,000	53,000	41,200
25.00	89,000	86,000	85,000	85,000	68,000	53,000	41,200
30.00	71,000	73,000	71,000	69,000	65,000	53,000	41,200
35.00	59,000	61,000	59,000	60,000	58,000	53,000	41,200
40.00		52,000	49,000	50,000	51,000	50,000	41,200
45.00		43,600	45,000	42,400	43,600	41,000	39,400
50.00		36,000	37,200	38,200	35,800	35,800	34,400
55.00			31,400	32,200	30,200	31,000	29,200
60.00			26,600	27,400	27,800	26,200	24,400
65.00			22,800	23,600	24,200	22,200	20,600
70.00			19,400	20,400	20,800	19,000	17,400
75.00				17,600	18,200	16,400	14,800
80.00				15,400	15,800	14,000	12,600
85.00				13,400	13,800	12,200	10,600
90.00					12,200	10,400	8,800
95.00					10,600	9,000	7,400
100.00					9,200	7,600	6,000
105.00						6,400	5,000
110.00						5,400	3,800
115.00						4,400	3,000
120.00						3,600	2,000



46 -151 ft.
(14.0-46.0 m)



9,300 lbs.
(4 218 kg)



360°

T1 T2 T3 %

T1	0.00	0.50/0.00	1.00/0.50/0.00	1.00/0.50/0.00	1.00/0.50/0.00	1.00/0.50	1.00
T2	0.00	0.00/0.25	0.00/0.25/0.50	0.25/0.50/0.75	0.50/0.75/1.00	0.75/1.00	1.00
T3	0.00	0.00/0.25	0.00/0.25/0.50	0.25/0.50/0.75	0.50/0.75/1.00	0.75/1.00	1.00



(Feet)



85% Domestic (Pounds)

(Feet)	46	64	81	99	116	133	151
10.00	219,000	198,000	136,000				
15.00	49,000	146,000	132,000	85,000			
20.00	106,000	103,000	102,000	85,000	72,000	53,000	41,200
25.00	82,000	84,000	82,000	80,000	68,000	53,000	41,200
30.00	65,000	68,000	65,000	65,000	60,000	53,000	41,200
35.00	50,000	53,000	55,000	51,000	49,000	46,000	41,200
40.00		40,400	42,000	43,000	39,600	39,000	35,200
45.00		32,000	33,400	34,400	35,000	32,000	28,600
50.00		25,600	27,200	28,000	28,600	26,600	23,600
55.00			22,200	23,200	23,800	21,800	19,400
60.00			18,400	19,200	19,800	18,000	16,000
65.00			15,200	16,200	16,800	14,800	13,200
70.00			12,800	13,600	14,200	12,200	10,600
75.00				11,400	12,000	10,200	8,600
80.00				9,600	10,200	8,400	6,800
85.00				8,000	8,600	6,800	5,200
90.00					7,200	5,400	3,800
95.00					6,000	4,200	2,600
100.00					4,800	3,000	
105.00						2,000	



46 -151 ft.
(14.0-46.0 m)



0 lbs.
(0 kg)



360°

T1 T2 T3 %

T1	0.00	0.50/0.00	1.00/0.50/0.00	1.00/0.50/0.00	1.00/0.50/0.00	1.00/0.50	1.00
T2	0.00	0.00/0.25	0.00/0.25/0.50	0.25/0.50/0.75	0.50/0.75/1.00	0.75/1.00	1.00
T3	0.00	0.00/0.25	0.00/0.25/0.50	0.25/0.50/0.75	0.50/0.75/1.00	0.75/1.00	1.00



(Feet)



85% Domestic (Pounds)

(Feet)	46	64	81	99	116	133	151
10.00	219,000	198,000	136,000				
15.00	143,000	140,000	127,000	85,000			
20.00	102,000	96,000	85,000	77,000	69,000	53,000	41,200
25.00	79,000	75,000	67,000	64,000	54,000	51,000	41,200
30.00	58,000	55,000	52,000	48,000	46,000	39,400	34,200
35.00	41,200	42,400	40,400	38,400	36,400	31,400	27,200
40.00		33,600	32,400	31,000	29,800	25,400	21,600
45.00		26,200	26,400	25,600	24,600	20,800	17,200
50.00		20,600	22,000	21,200	20,600	16,800	13,600
55.00			17,800	17,600	17,200	13,600	10,600
60.00			14,400	14,600	14,200	11,000	8,200
65.00			11,400	12,200	11,800	8,800	6,000
70.00			9,200	10,000	9,800	7,000	4,400
75.00				8,000	8,200	5,400	2,800
80.00				6,400	6,800	4,000	
85.00				5,000	5,400	2,800	
90.00					4,200		
95.00					3,200		
100.00					2,200		

THIS CHART IS ONLY A GUIDE AND SHOULD NOT BE USED TO OPERATE THE CRANE. The individual crane's load chart, operating instructions and other instructional plates must be read and understood prior to operating the crane.



99 - 151 ft.
(30.0 - 46.0 m)



27,800 lbs.
(12 610 kg)



360°

T1 T2 T3 %

	33' - 0°	33' - 0°	33' - 0°	33' - 0°	33' - 16°	33' - 16°	33' - 16°	33' - 16°	33' - 30°	33' - 30°	33' - 30°	33' - 30°
T1	1.00/0.00	1.00/0.00	1.00	1.00	1.00/0.00	1.00/0.00	1.00	1.00	1.00/0.00	1.00/0.00	1.00	1.00
T2	0.25/0.75	0.50/1.00	0.75	1.00	0.25/0.75	0.50/1.00	0.75	1.00	0.25/0.75	0.50/1.00	0.75	1.00
T3	0.25/0.75	0.50/1.00	0.75	1.00	0.25/0.75	0.50/1.00	0.75	1.00	0.25/0.75	0.50/1.00	0.75	1.00



85% Domestic (Pounds)

(Feet)	99	116	133	151	99	116	133	151	99	116	133	151
20.00	30,800	28,600										
25.00	30,400	28,600	24,000		21,000							
30.00	27,600	27,400	24,000	20,600	19,600	19,800	19,600		15,200			
35.00	25,200	25,600	24,000	20,600	18,400	18,800	18,600		14,400	14,400		
40.00	23,200	23,800	23,600	20,600	17,400	17,800	17,800	17,400	13,800	14,000	14,000	13,600
45.00	21,400	22,400	22,200	20,400	16,400	17,000	17,000	16,800	13,200	13,400	13,600	13,400
50.00	19,800	21,000	21,200	20,400	15,600	16,200	16,400	16,200	12,800	13,000	13,200	13,000
55.00	18,600	19,600	20,000	19,800	14,800	15,400	15,600	15,600	12,400	12,600	12,800	12,800
60.00	17,400	18,600	19,000	19,000	14,000	14,600	14,800	14,800	12,000	12,400	12,600	12,400
65.00	16,400	17,600	18,200	18,200	13,000	13,600	14,000	14,200	11,600	12,000	12,200	12,200
70.00	15,400	16,600	17,400	17,400	12,600	13,200	13,600	13,600	11,200	11,600	11,800	12,000
75.00	14,400	15,600	16,200	16,600	12,000	12,600	13,000	13,200	11,000	11,400	11,600	11,600
80.00	13,200	14,200	13,800	14,200	11,600	12,200	12,600	12,800	10,600	11,000	11,200	11,400
85.00	12,600	13,600	11,800	12,200	11,200	11,800	12,200	12,600	10,400	10,800	11,000	11,200
90.00	12,000	13,000	10,200	10,400	10,800	11,400	11,000	11,400	10,200	10,600	10,800	11,000
95.00	11,600	12,400	8,600	9,000	10,400	11,000	9,400	9,800	10,000	10,200	10,000	10,600
100.00	11,000	11,000	7,200	7,600	10,200	10,600	8,000	8,400	9,800	10,000	8,600	9,000
105.00	9,800	9,800	6,000	6,400	10,000	10,200	6,800	7,200		10,000	7,200	7,800
110.00	8,800	8,800	5,000	5,400	9,000	9,200	5,600	6,000		9,400	6,000	6,600
115.00	7,800	7,800	4,000	4,400	8,000	8,000	4,600	5,000		8,200	5,000	5,400
120.00		6,800	3,200	3,600		7,200	3,800	4,200			4,000	4,400
125.00		6,000	2,400	2,800		6,200	2,800	3,200			3,200	3,600
130.00		5,200		2,000		5,400	2,000	2,400			2,200	2,800
135.00		4,600										2,000



99 - 151 ft.
(30.0 - 46.0 m)



27,800 lbs.
(12 610 kg)



360°

T1 T2 T3 %

	53' - 0°	53' - 0°	53' - 0°	53' - 0°	53' - 16°	53' - 16°	53' - 16°	53' - 16°	53' - 30°	53' - 30°	53' - 30°	53' - 30°
T1	1.00/0.00	1.00/0.00	1.00	1.00	1.00/0.00	1.00/0.00	1.00	1.00	1.00/0.00	1.00/0.00	1.00	1.00
T2	0.25/0.75	0.50/1.00	0.75	1.00	0.25/0.75	0.50/1.00	0.75	1.00	0.25/0.75	0.50/1.00	0.75	1.00
T3	0.25/0.75	0.50/1.00	0.75	1.00	0.25/0.75	0.50/1.00	0.75	1.00	0.25/0.75	0.50/1.00	0.75	1.00



85% Domestic (Pounds)

(Feet)	99	116	133	151	99	116	133	151	99	116	133	151
20.00	15,400											
25.00	15,400	15,400										
30.00	15,400	15,400	14,600									
35.00	15,400	15,400	14,400	13,400	11,600							
40.00	15,200	15,400	14,000	13,200	11,000	11,200	11,000					
45.00	13,800	14,200	13,800	12,800	10,400	10,600	10,600		8,600			
50.00	12,800	13,200	13,400	12,400	9,800	10,000	10,200	10,000	8,200	8,400	8,400	
55.00	12,000	12,600	12,600	12,200	9,400	9,600	9,800	9,800	8,000	8,000	8,200	8,000
60.00	11,200	11,800	12,000	11,800	9,000	9,200	9,400	9,400	7,600	7,800	8,000	7,800
65.00	10,600	11,200	11,400	11,400	8,600	8,800	9,000	9,000	7,400	7,600	7,600	7,600
70.00	10,000	10,600	11,000	11,000	8,200	8,600	8,800	8,800	7,200	7,400	7,400	7,600
75.00	9,600	10,200	10,600	10,600	7,800	8,200	8,400	8,600	7,000	7,200	7,200	7,400
80.00	9,000	9,600	10,000	10,200	7,600	7,800	8,200	8,200	6,800	7,000	7,000	7,200
85.00	8,600	9,200	9,600	9,800	7,200	7,600	7,800	8,000	6,600	6,800	7,000	7,000
90.00	8,200	8,800	9,200	9,400	7,000	7,400	7,600	7,800	6,400	6,600	6,800	6,800
95.00	7,800	8,400	8,800	9,200	6,800	7,200	7,400	7,600	6,200	6,400	6,600	6,600
100.00	7,400	8,000	8,600	8,800	6,600	7,000	7,200	7,400	6,000	6,200	6,400	6,600
105.00	7,200	7,600	7,400	7,600	6,400	6,800	7,000	7,200	6,000	6,000	6,400	6,400
110.00	6,800	7,400	6,400	6,600	6,200	6,800	6,800	7,000	6,000	6,000	6,200	6,400
115.00	6,600	7,200	5,400	5,600	6,000	6,600	6,600	6,800	5,800	6,000	6,200	6,200
120.00	6,400	6,800	4,600	4,600	5,800	6,400	5,600	5,800	5,800	5,800	6,000	6,200
125.00	6,200	6,600	3,800	3,800	5,800	6,200	4,600	4,800		5,800	5,400	5,600
130.00	5,800	6,400	3,000	3,200	5,600	6,000	3,800	4,000		5,600	4,400	4,800
135.00	5,600	5,600	2,400	2,400	5,600	5,800	3,200	3,400		5,600	3,600	4,000
140.00		5,000				5,800	2,400	2,600			2,800	3,200
145.00		4,400				5,400		2,000			2,200	2,400
150.00		3,800				4,800						
155.00		3,400				4,200						

THIS CHART IS ONLY A GUIDE AND SHOULD NOT BE USED TO OPERATE THE CRANE. The individual crane's load chart, operating instructions and other instructional plates must be read and understood prior to operating the crane.



99 - 151 ft.
(30.0 - 46.0 m)

9,300 lbs.
(4 218 kg)

360°

T1 T2 T3 %

	33' - 0°	33' - 0°	33' - 0°	33' - 0°	33' - 16°	33' - 16°	33' - 16°	33' - 16°	33' - 30°	33' - 30°	33' - 30°	33' - 30°
T1	1.00/0.00	1.00/0.00	1.00	1.00	1.00	1.00/0.00	1.00	1.00	1.00	1.00/0.00	1.00	1.00
T2	0.25/0.75	0.50/1.00	0.75	1.00	0.25	0.50/1.00	0.75	1.00	0.25	0.50/1.00	0.75	1.00
T3	0.25/0.75	0.50/1.00	0.75	1.00	0.25	0.50/1.00	0.75	1.00	0.25	0.50/1.00	0.75	1.00



85% Domestic (Pounds)

(Feet)	99	116	133	151	99	116	133	151	99	116	133	151
20	30,800	28,600										
25	30,400	28,600	24,000		21,000							
30	27,600	27,400	24,000	20,600	19,600	19,800	19,600		15,200			
35	25,200	25,600	24,000	20,600	18,400	18,800	18,600		14,400	14,400		
40	23,200	23,800	23,600	20,600	17,400	17,800	17,800	17,400	13,800	14,000	14,000	13,600
45	21,400	22,400	22,200	20,400	16,400	17,000	17,000	16,800	13,200	13,400	13,600	13,400
50	19,899	21,000	21,200	20,400	15,600	16,200	16,400	16,200	12,800	13,000	13,200	13,000
55	18,600	19,600	20,000	19,800	14,800	15,400	15,600	15,600	12,400	12,600	12,800	12,800
60	17,200	18,000	17,400	17,200	14,000	14,600	14,800	14,800	12,000	12,400	12,600	12,400
65	16,000	17,000	14,600	14,400	13,000	13,600	14,000	14,200	11,600	12,000	12,200	12,200
70	15,200	16,000	12,000	12,200	12,400	13,000	13,600	13,600	11,200	11,600	11,800	12,000
75	14,000	14,000	10,000	10,200	12,000	12,600	11,200	11,600	11,000	11,400	11,600	11,600
80	12,000	12,000	8,000	8,400	11,400	12,000	9,200	9,600	10,600	11,000	10,200	10,600
85	10,400	10,400	6,600	6,800	11,000	11,200	7,600	8,000	10,400	10,600	8,400	8,800
90	9,000	9,000	5,200	5,400	9,600	9,600	6,200	6,400	10,000	10,200	6,800	7,200
95	7,800	7,800	4,000	4,200	8,200	8,400	4,800	5,200	8,600	8,800	5,400	5,800
100	6,600	6,600	2,800	3,200	7,000	7,200	3,600	4,000	7,200	7,600	4,200	4,600
105	5,600	5,600		2,200	6,000	6,200	2,600	3,000		6,400	3,000	3,600
110	4,800	4,800			5,000	5,200		2,000		5,400	2,000	2,600
115	4,000	4,000			4,200	4,200				4,400		
120		3,200				3,400						
125		2,600				2,800						
130		1,800				2,000						



99 - 151 ft.
(30.0 - 46.0 m)

9,300 lbs.
(4 218 kg)

360°

T1 T2 T3 %

	53' - 0°	53' - 0°	53' - 0°	53' - 0°	53' - 16°	53' - 16°	53' - 16°	53' - 16°	53' - 30°	53' - 30°	53' - 30°	53' - 30°
T1	1.00/0.00	1.00/0.00	1.00	1.00	1.00/0.00	1.00/0.00	1.00	1.00	1.00/0.00	1.00/0.00	1.00	1.00
T2	0.25/0.75	0.50/1.00	0.75	1.00	0.25/0.75	0.50/1.00	0.75	1.00	0.25/0.75	0.50/1.00	0.75	1.00
T3	0.25/0.75	0.50/1.00	0.75	1.00	0.25/0.75	0.50/1.00	0.75	1.00	0.25/0.75	0.50/1.00	0.75	1.00



85% Domestic (Pounds)

(Feet)	99	116	133	151	99	116	133	151	99	116	133	151
20.00	15,400											
25.00	15,400	15,400										
30.00	15,400	15,400	14,600									
35.00	15,400	15,400	14,400	13,400	11,600							
40.00	15,200	15,400	14,000	13,200	11,000	11,200	11,000					
45.00	13,800	14,200	13,800	12,800	10,400	10,600	10,600		8,600			
50.00	12,800	13,200	13,400	12,400	9,800	10,000	10,200	10,000	8,200	8,400	8,400	
55.00	12,000	12,600	12,600	12,200	9,400	9,600	9,800	9,800	8,000	8,000	8,200	8,000
60.00	11,200	11,800	12,000	11,800	9,000	9,200	9,400	9,400	7,600	7,800	8,000	7,800
65.00	10,600	11,200	11,400	11,400	8,600	8,800	9,000	9,000	7,400	7,600	7,600	7,600
70.00	10,000	10,600	11,000	11,000	8,200	8,600	8,800	8,800	7,200	7,400	7,400	7,600
75.00	9,600	10,200	10,600	10,600	7,800	8,200	8,400	8,600	7,000	7,200	7,200	7,400
80.00	9,000	9,400	9,600	9,600	7,600	7,800	8,200	8,200	6,800	7,000	7,000	7,200
85.00	8,400	9,000	8,000	8,000	7,200	7,600	7,800	8,000	6,600	6,800	7,000	7,000
90.00	8,000	8,600	6,600	6,800	7,000	7,400	7,600	7,800	6,400	6,600	6,800	6,800
95.00	7,800	8,200	5,400	5,600	6,800	7,000	7,000	7,200	6,200	6,400	6,600	6,600
100.00	7,400	7,800	4,200	4,400	6,600	6,800	5,800	6,000	6,000	6,200	6,400	6,600
105.00	7,000	6,800	3,200	3,400	6,400	6,600	4,600	4,800	6,000	6,200	5,600	5,800
110.00	6,000	5,800	2,400	2,600	6,200	6,600	3,600	3,800	5,800	6,000	4,600	4,800
115.00	5,200	5,000			5,800	5,800	2,800	3,000	5,800	6,000	3,600	3,800
120.00	4,600	4,400			5,000	5,000	2,000	2,200	5,400	5,400	2,600	3,000
125.00	3,800	3,600			4,200	4,200				4,600		2,200
130.00	3,200	3,000			3,600	3,600				4,000		
135.00	2,600	2,400			2,800	3,000				3,200		
140.00		2,000				2,400						

THIS CHART IS ONLY A GUIDE AND SHOULD NOT BE USED TO OPERATE THE CRANE. The individual crane's load chart, operating instructions and other instructional plates must be read and understood prior to operating the crane.

Rated Lifting Capacities

IMPORTANT NOTES:

WARNING: THIS CHART IS ONLY A GUIDE.

The notes below are for illustration only and should not be relied upon to operate the crane. The individual crane's load chart, operating instructions and other instruction plates must be read and understood prior to operating the crane.

1. All rated have been tested to and meet minimum requirements of SAEJ1063 OCT80 - Cantilevered Boom Crane Structures - Method of Test, and do not exceed 85% of the tipping load on outriggers as determined by SAEJ765 OCT80 Crane Stability Test Code.





























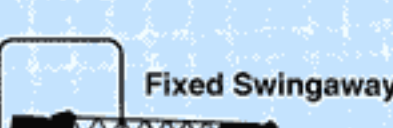

2. Capacities given do not include the weight of hookblocks, slings, auxiliary lifting equipment and load handling devices. Their weights must be added to the load to be lifted. When more than minimum required reeving is used, the additional rope weight shall be considered part of the load.

3. All capacities are for crane on firm, level surface. It may be necessary to have structural supports under the outrigger floats to spread the load to a larger bearing surface.

4. When either boom length or radius or both are between values listed, the smallest load shown at either the next larger radius or boom length shall be used.

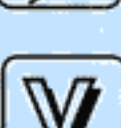
5. For outrigger operation, ALL outriggers shall be properly extended with tires raised free of ground before raising the boom or lifting loads.

Symbols Glossary

	Frame		Steering
	Outriggers		Transmission
	Outrigger Controls		Axles
	Engine		Brakes
	Fuel Tank Capacity		Tires
	Electrical System		Suspension
	Drive		360° Rotation
	Lights		Boom Elevation
	Cab		Swing
	Boom		Counterweight
	Fixed Swingaway		Oil
	Tele-Swingaway		Hydraulic System
	Jib		Hoist
	Boom Nose		Radius
	Boom Extension		Boom Length
	Speed		Hookblock
	Grade		Gear
	Lattice Extension		

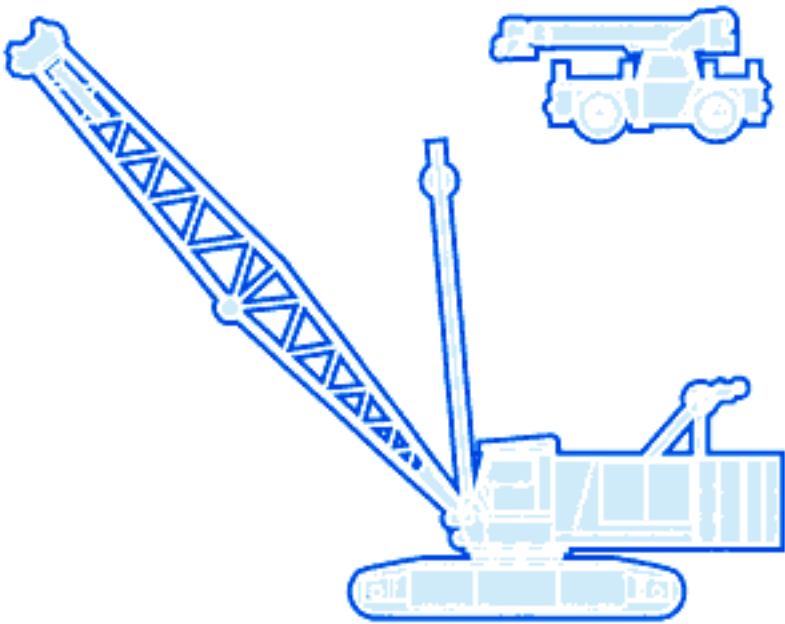

Grove Worldwide – World Headquarters

1565 Buchanan Trail East
P.O. Box 21
Shady Grove, Pennsylvania 17256, U.S.A.
Tel: [Int + 1] (717) 597-8121
Fax: [Int + 1] (717) 597-4062
Western Hemisphere, Asia/Pacific

Grove Europe*

Sunderland SR4 6TT, England
Tel: [Int +44] 191 565-6281
Fax: [Int + 44] 191 564-0442
Europe, Africa, Middle East

Deutsche Grove GmbH

Sales and Service

Helmholtzstrasse 12, Postfach 5026
D-40750 Langenfeld, Germany
Tel: [Int + 49] (2173) 8909-0
Fax: [Int + 49] (2173) 8909-30

Wilhelmshaven Works

Industriegelände West, Postfach 1853
D-26358 Wilhelmshaven, Germany
Tel: [Int +49] (4421) 294-0
Fax: [Int +49] (4421) 294-301

Grove France S.A.

16, chaussée Jules-César, 95520 OSNY
B.P. 203, 95523 CERGY PONTOISE CEDEX
France
Tel: [Int + 33] (1) 30313150
Int: [Int + 33] (1) 30386085

Grove Asia/Pacific - Regional Office

171 Chin Swee Road
#06-01 Sun Centre
Singapore 0316
Tel: [Int +65] 536-6112
Fax: [Int + 65] 536-6119
Asia/Pacific, Near East

*Grove Europe Limited, Registered in England,
Number 1845128, Registered office, Crown Works,
Pallion, Sunderland, Tyne & Wear, England SR4 6TT

Constant improvement and engineering progress make it necessary that we reserve the right to make specification, equipment, and price changes without notice. Illustrations shown may include optional equipment and accessories and may not include all standard equipment.

Distributed By: