

GMK4080-3 Product Guide

ASME B30.5
Imperial 85%



Features

- 80 t (88 USt) capacity
- 51 m (167 ft) six-section main boom
- 8,7 m - 15 m (28.5 ft - 49.2 ft) swingaway extension
- 6 m (19.7 ft) boom extension
- Single-engine concept design
- MAXbase variable outrigger positioning

GROVE GMK4080-3

Compact and Strong: With high capacities and industry-leading compact dimensions, the GMK4080-3 allows you to secure more jobs than ever before.

Features

> Industry-leading compact dimensions

The minimum width of the GMK4080-3 is 2,55 m (8.4 ft) with 14.00 R25 tires and 2,75 m (9 ft) with 16.00 R25 tires. With an overall length of 12,68 m (41.6 ft) and a narrow tail swing of only 3,5 m (11.6 ft) this is one of the most compact cranes in its class making it easy to work in confined job sites.

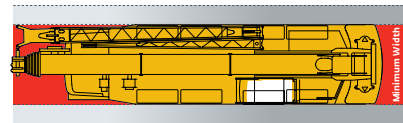

> MAXbase variable outrigger positioning

MAXbase provides increased flexibility on the job site by allowing asymmetrical outrigger spans. This makes it easier to work in congested jobsites with obstructions and allows for increased capacities.

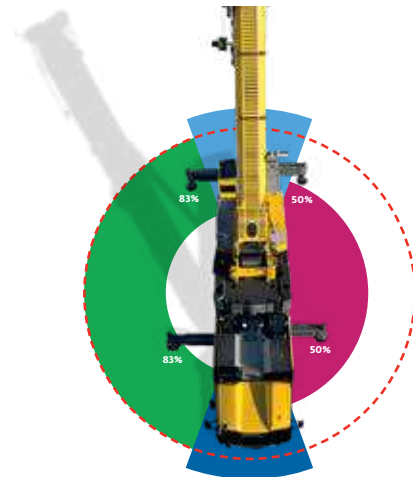

> Single-engine concept

The new single engine concept on the GMK4080-3 with the latest EUROMOT 5 / Tier 4 final engine reduces fuel consumption to a minimum. Using the ECO mode, the GMK4080-3 is the most fuel efficient crane in its class.



Jobsite benefits

- > Access narrow jobsites and utilize a more compact radius to gain a better position for lift performance. The GMK4080-3's compact size and MAXbase variable outrigger positioning system provides excellent job site flexibility unmatched in the market.
- > Human Machine Interface (HMI) allows for control of the MEGATRAK™ suspension system from both sides of the carrier allowing for adjustment of ground clearance independent of the outriggers. The GMK4080-3 can also be equipped with an outrigger pad load indicator with visibility on both sides of the carrier or from the operators cab.
- > MEGATRAK™ independent suspension, all-wheel steering system and steer by wire technology provides increased ground clearance, adjustable suspension and reduces tire-wear to provide maximum maneuverability in all-terrains.

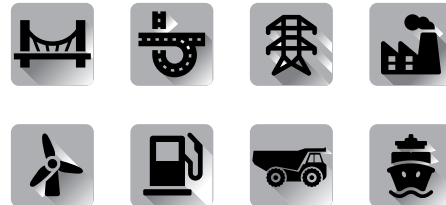

What you need, when you need it.

Get right to work with the right equipment — Manitowoc Finance gives you access to flexible, affordable financing you can use to seize profitable new opportunities as they arise.

Feel confident in your investment — rest easy with the assurance of the world's most advanced crane service and support network.

Contents

- Dimensions 5
- Data 8
- Weights 9
- Working range - Main boom 10
- Load charts - Main boom 11
- Working range - Swingaway extension 18
- Load charts - Swingaway extension 19
- Specifications 22
- Symbols glossary 23

Dimensions

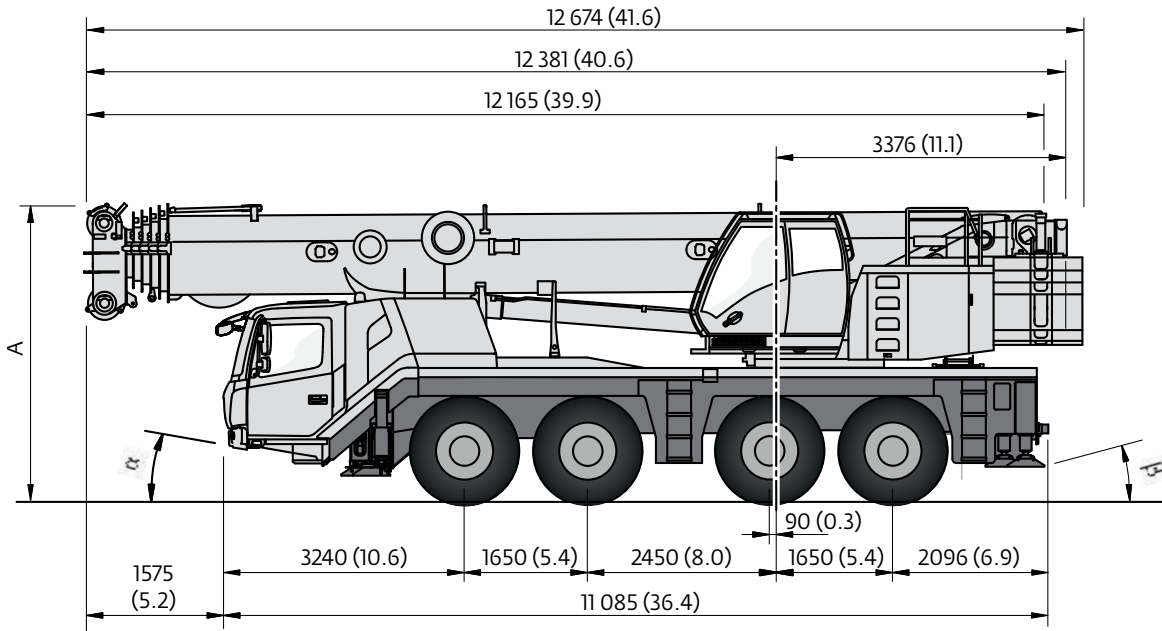

Dimensions shown are in mm (ft).

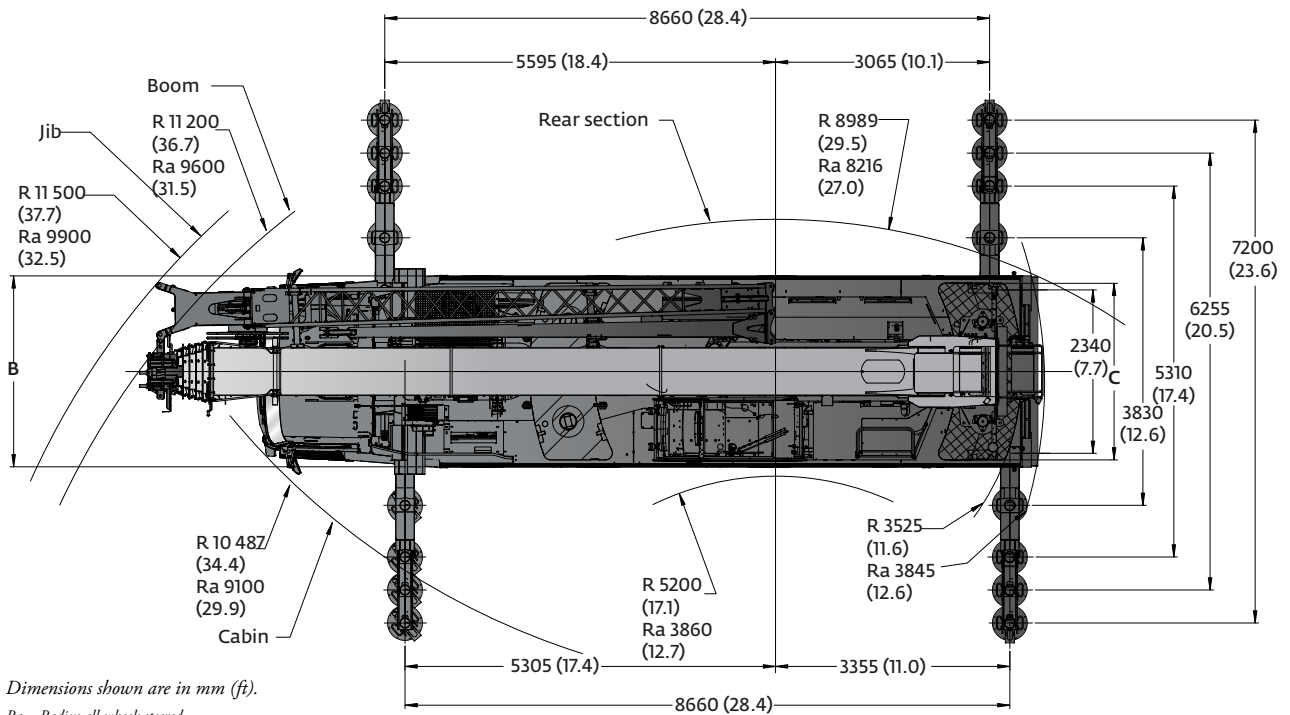

Dimensions shown are in mm (ft).

Ra = Radius all wheels steered

	A	A 126 mm* (0.4)	B	C	D	E	F	α	β	βI
14.00 R25	3940 (12.9)	3810 (12.5)	2550 (8.4)	2320 (7.6)	1750 (5.7)	435 (1.4)	262 (0.9)	14	21	17
16.00 R25	3990 (13.1)	3860 (12.7)	2750 (9.0)	2280 (7.5)	1863 (6.1)	485 (1.6)	292 (1.0)	16	23	19
20.5 R25	3990 (13.1)	3860 (12.7)	2880 (9.4)	2320 (7.6)	1863 (6.1)	485 (1.6)	292 (1.0)	16	23	19

* Lowered

Dimensions

Jib configurations

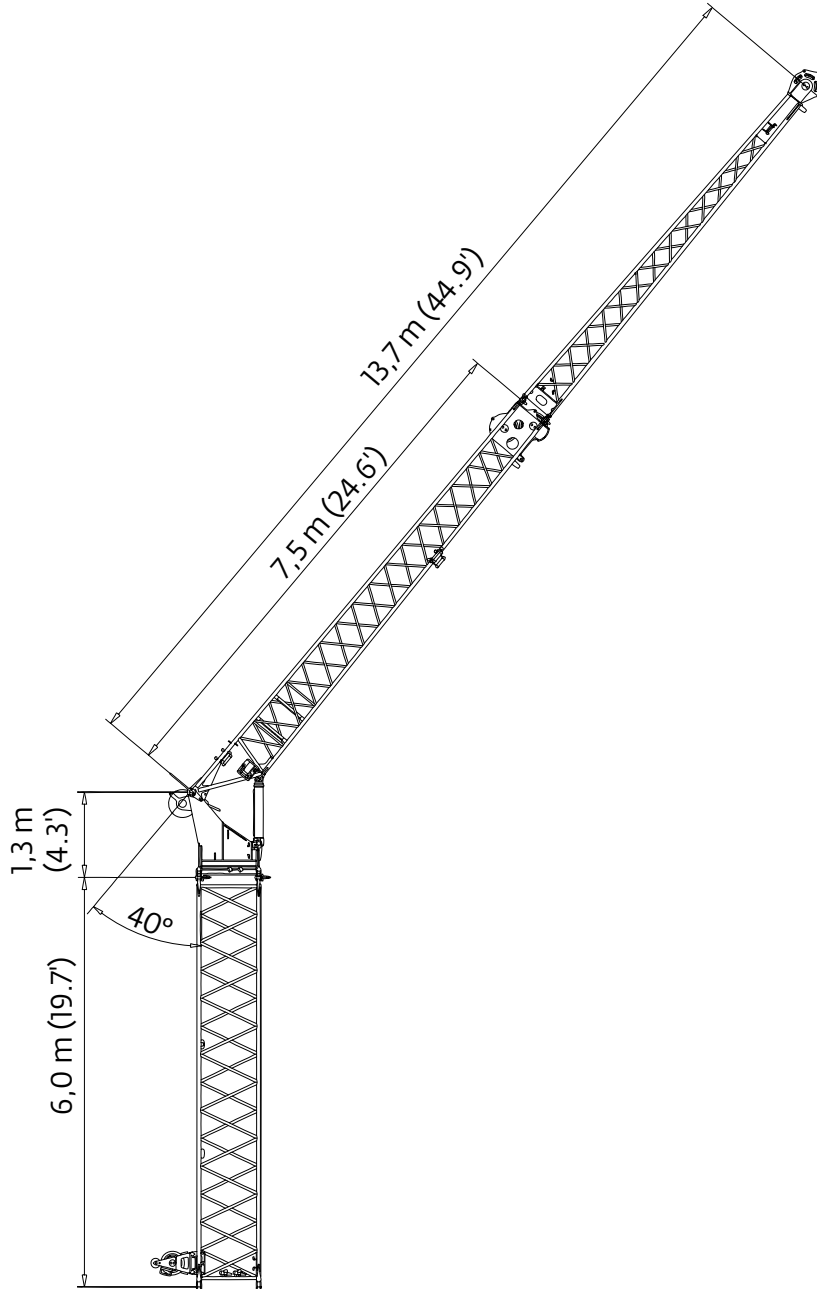

Total Length	Intermediate section boom extension make-up			
	6,0 m (19.7 ft)	1,3 m (4.3 ft)	7,5 m (24.6 ft)	6,2 m (20.3 ft)
m (ft)				
8,7 (28.5)	-	1x	1x	-
15,0 (49.2)	-	1x	1x	1x
21,0 (68.9)	1x	1x	1x	1x

Dimensions

Counterweight

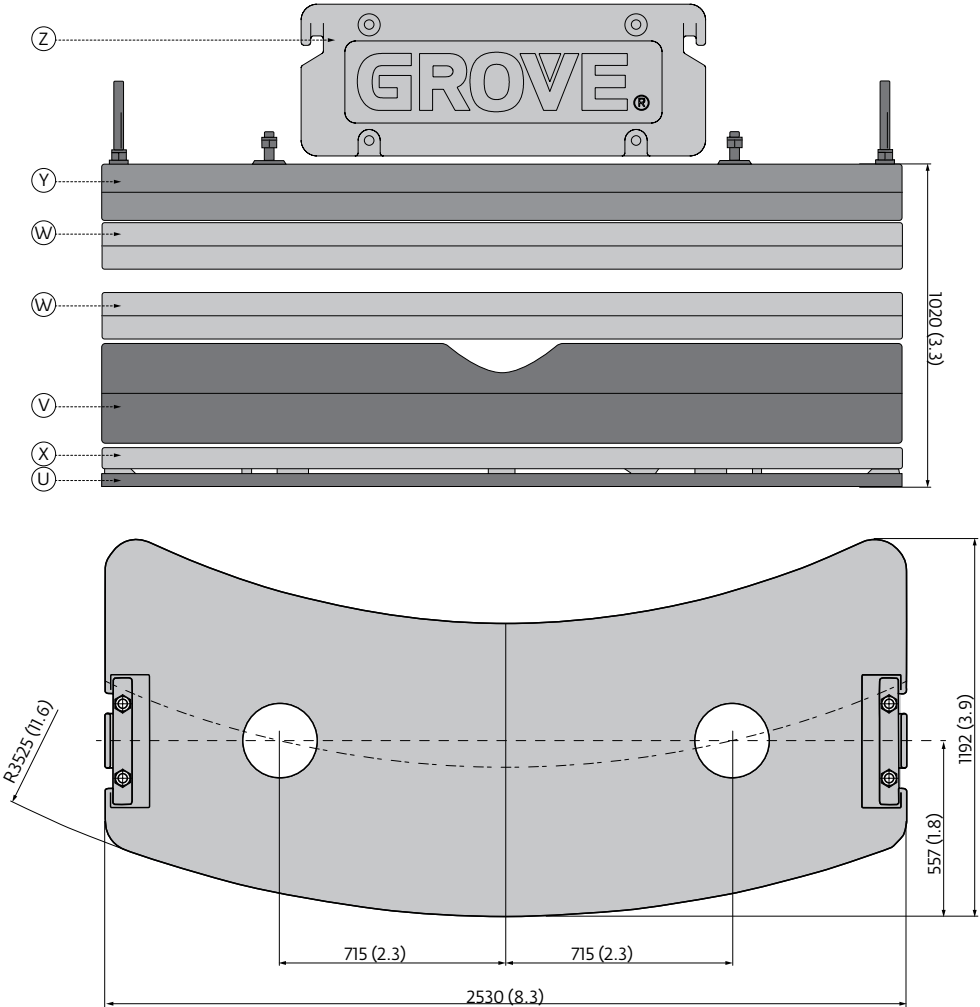

	Z 0,5 t (0.6 USt)	Y 2,9 t (3.2 USt)	X 1,15 t (1.3 USt)	W 2,3 t (2.5 USt)	V 4,6 t (5.1 USt)	U 1,1 t (1.2 USt)
0,5 t (1100 lb)	x					
3,4 t (7400 lb)	x	x				
4,5 t (9900 lb)	x	x				x
5,7 t (12,500 lb)	x	x	x			x
6,8 t (14,900 lb)	x	x		x		x
8 t (17,600 lb)	x	x	x	x		x
9,1 t (20,000 lb)	x	x		2x		x
10,2 t (22,400 lb)	x	x	x	2x		x
11,4 t (25,100 lb)	x	x		x	x	x
12,5 t (27,500 lb)	x	x	x	x	x	x
13,7 t (30,200 lb)	x	x		2x	x	x
14,8 t (32,600 lb)	x	x	x	2x	x	x

Data



Lifting Capacity	Sheaves	Weight	Parts of line	Possible load with crane
80 t (88 USt)	7	800 kg (1770 lb)	2 - 12 / **15	58 t / 74 t** (63.9/81.6 USt)
63 t (69 USt)	5	650 kg (1430 lb)	2 - 11	54 t (59.5 USt)
40 t (44 USt)	3	450 kg (1000 lb)	2 - 7	35 t (35.6 USt)
16 t (18 USt)	1	300 kg (660 lb)	1 - 3	15 t (16.5 USt)
8 t (9 USt)	overhaul weight	200 kg (440 lb)	1	5 t (5.5 USt)

** Requires additional boom nose sheave

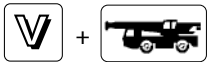

	1	2	3	4	5	6	7	8	9	10	11	12	13	14	15	16	R1	R2	
	3.9	4.7	5.8	7.0	8.7	10.5	12.4	15.5	17.4	21.1	25.5	31.1	38.5	46.6	52.8	52.8	3.9	4.8	
	1.8	2.2	2.6	3.1	3.9	4.7	5.6	6.8	8.0	9.3	11.8	14.3	17.4	21.1	25.5	30.4	1.8	2.2	70%
	14.00 R25																		

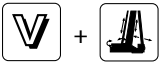

	Infinitely variable	Rope	Max. Single line pull
	0 - 120 m/min (394 fpm) Single line	16 mm / 220 m (720 ft)	50,0 kN (11,240 lb)
	0 - 120 m/min (394 fpm) Single line	16 mm / 220 m (720 ft)	50,0 kN (11,240 lb)
	0 - 1,7 min ⁻¹		
	-3,0° to + 82° approx. < 45 s		
	11,3 m - 51,0 m (37.1 ft - 167.3 ft) approx. < 335 s		

Weights

Boom over front

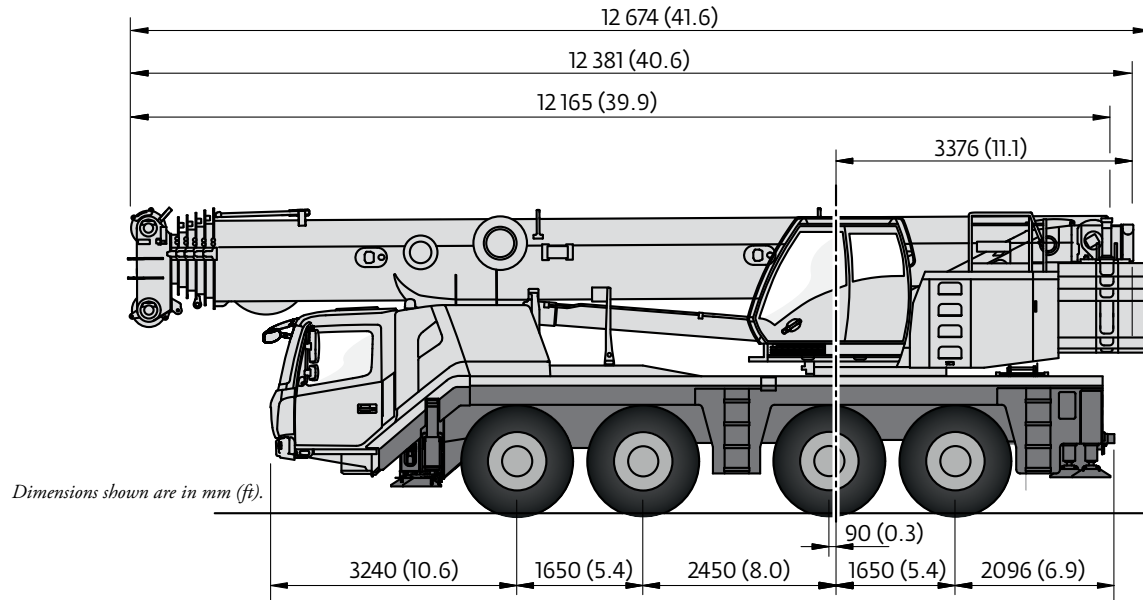

Basic Weights - kg (lb)	Axles 1 and 2		Axles 3 and 4		Total	
Mercedes power T4F, 16.00 R25 on steel wheels, 8x6x8, hydraulic swingaway, jib brackets, hose reel, aux hoist, nylatron outrigger pads, trailing boom float kit, 5.2t (5.7USt) counterweight attached to superstructure, 3 sheave hook block, single line overhaul ball, and full fuel tank.	22 600 kg	49,820 lb	22 720 kg	50,080 lb	45 310 kg	99,890 lb
Additions						
8X8X8 drive/steer	244 kg	537 lb	59 kg	129 lb	303 kg	666 lb
Spare wheel 14.00 R25 XGC steel rim with stowage	-206 kg	-455 lb	477 kg	1052 lb	271 kg	597 lb
Spare wheel 16.00 R25 XGC steel rim with stowage	-247 kg	-544 lb	571 kg	1258 lb	324 kg	714 lb
Spare wheel 20.5 R25 XGC steel rim with stowage	-295 kg	-650 lb	682 kg	1503 lb	387 kg	853 lb
Substitutions						
14.00R25 tires	-212 kg	-468 lb	-212 kg	-468 lb	-424 kg	-936 lb
20.5R25 tires	252 kg	555 lb	252 kg	555 lb	504 kg	1110 lb
Removals						
Auxiliary hoist	546 kg	1203 lb	-1398 kg	-3081 lb	-852 kg	-1878 lb
Front and rear nylatron outrigger floats	-59 kg	-131 lb	-72 kg	-159 lb	-131 kg	-290 lb

For additional travel configurations, please consult the factory.

Working range

Main boom



11,0 m - 51,0 m (36 ft - 167 ft)



7,2 m (23.6 ft)



360°

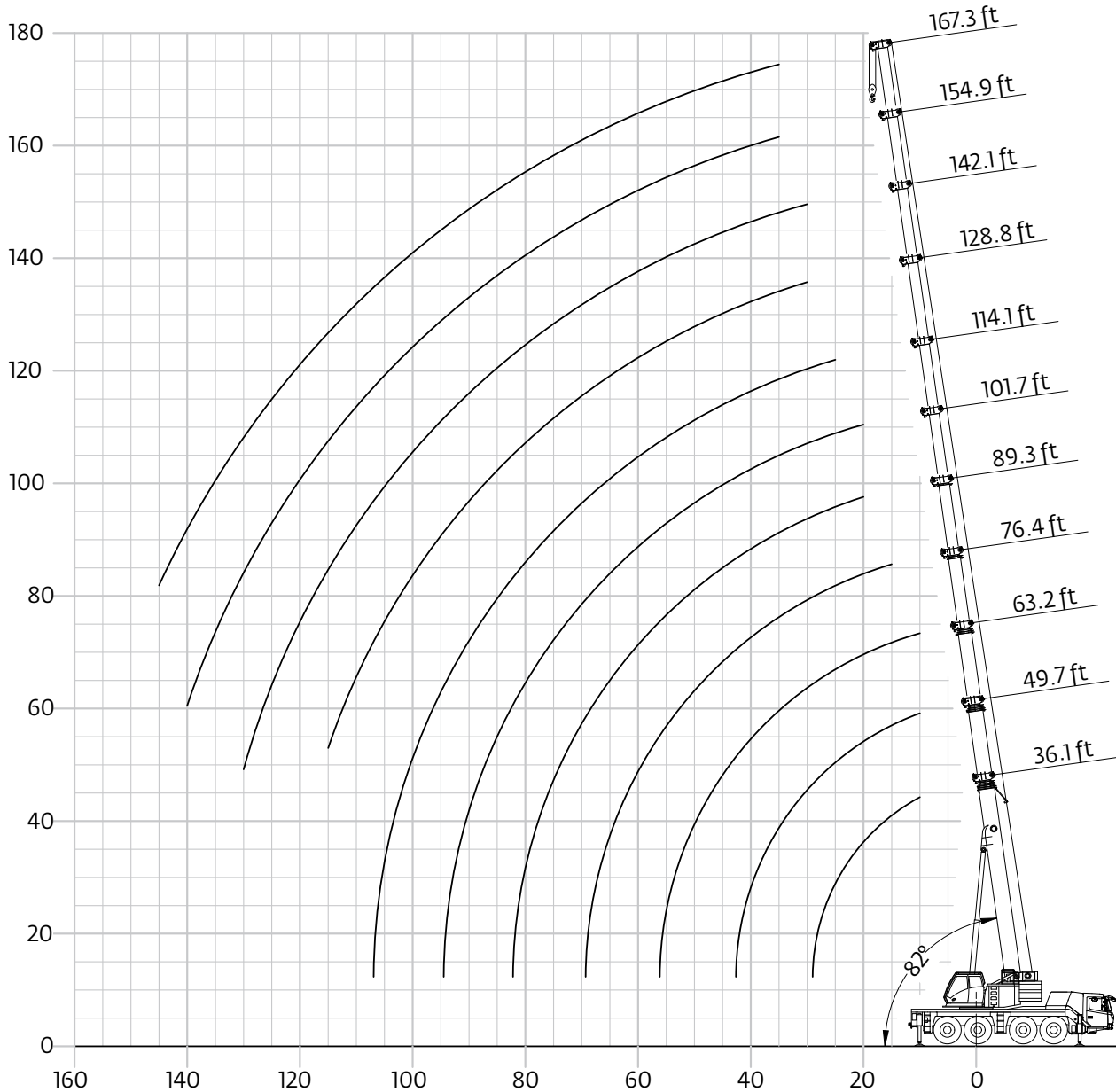

	Hook block T (USt)	H mm (ft)
	80 D (88)	3200 (10.5)
63 D (69)	3000 (9.8)	
40 D (44)	2900 (9.5)	
16 E (18)	2800 (9.2)	
8 overhaul weight (9)	2350 (7.7)	

THIS CHART IS ONLY A GUIDE AND SHOULD NOT BE USED TO OPERATE THE CRANE.

The individual crane's load chart, operating instructions and other instructional plates must be read and understood prior to operating the crane

Load charts

Main boom



11,0 m - 51,0 m
(36 ft - 167 ft)



7,2 m
(23.6 ft)



360°



14,8 t
(32,600 lb)



Pounds x 1000

Feet	36.1	48.5-49.7	61-63.2	73.8-76.4	86.6-89.3	99.9-101.7	113.2-115.3	126.6-128.8	140.1-142.1	153.7-154.9	167.3	Feet
10.0	154.0	126.0	118.0									10.0
15.0	109.0	104.0	97.0	91.0								15.0
20.0	85.0	86.0	83.0	77.0	74.0	59.0						20.0
25.0	67.0	68.0	67.0	67.0	65.0	56.0	43.6					25.0
30.0		55.0	54.0	55.0	54.0	51.0	40.6	33.8	26.2			30.0
35.0		47.0	46.0	47.0	43.4	43.0	37.0	32.4	26.2	20.2	16.6	35.0
40.0		34.0	37.6	38.4	38.4	35.8	33.2	29.8	26.2	20.2	16.6	40.0
45.0			31.0	32.0	32.6	30.2	28.2	27.2	24.8	20.2	16.6	45.0
50.0			26.8	28.6	28.0	26.0	24.6	23.4	23.0	20.2	16.6	50.0
55.0			12.8	24.6	24.2	22.4	23.0	20.2	20.0	19.2	16.6	55.0
60.0				21.2	20.8	19.8	20.2	17.6	17.4	17.6	16.6	60.0
65.0				18.6	18.2	18.8	18.0	16.4	15.4	15.6	15.6	65.0
70.0					16.0	17.0	16.0	15.4	14.4	14.4	14.0	70.0
75.0					14.0	15.0	14.2	14.4	13.6	13.4	12.6	75.0
80.0					10.4	13.4	12.4	13.0	12.8	12.2	11.2	80.0
85.0						12.0	11.0	11.6	11.4	11.0	10.0	85.0
90.0						10.8	9.8	10.2	10.4	10.0	9.0	90.0
95.0							8.8	9.6	9.4	9.0	8.0	95.0
100.0							8.2	9.0	8.6	8.2	7.2	100.0
105.0							7.8	8.2	7.8	7.2	6.4	105.0
110.0								7.4	7.0	6.4	5.8	110.0
115.0								6.8	6.2	5.8	5.0	115.0
120.0									5.6	5.0	4.4	120.0
125.0									5.0	4.6	3.8	125.0
130.0									4.4	4.0	3.2	130.0
135.0										3.4	2.8	135.0
140.0										3.0	2.4	140.0
145.0											2.0	145.0
150.0												150.0
155.0												155.0
160.0												160.0

*Lifting loads > 130,000 lbs. can be lifted only with additional equipment

THIS CHART IS ONLY A GUIDE AND SHOULD NOT BE USED TO OPERATE THE CRANE.

The individual crane's load chart, operating instructions and other instructional plates must be read and understood prior to operating the crane

Load charts

Main boom



11,0 m - 51,0 m
(36 ft - 167 ft)



7,2 m
(23.6 ft)



360°



13,7 t (30,200 lb)



Pounds x 1000

Feet	36.1	48.5-49.7	61-63.2	73.8-76.4	86.6-89.3	99.9-101.7	113.2-115.3	126.6-128.8	140.1-142-1	153.7-154.9	167.3	Feet
10.0	154.0	126.0	118.0									10.0
15.0	109.0	104.0	97.0	91.0								15.0
20.0	84.0	85.0	83.0	77.0	74.0	59.0						20.0
25.0	66.0	67.0	67.0	66.0	65.0	56.0	43.6					25.0
30.0		55.0	54.0	55.0	52.0	51.0	40.6	33.8	26.2			30.0
35.0		46.0	46.0	45.0	43.4	41.2	37.0	32.4	26.2	20.2	16.6	35.0
40.0		34.2	37.6	36.8	36.8	34.2	32.0	29.8	26.2	20.2	16.6	40.0
45.0			31.0	31.6	31.2	28.8	27.0	26.0	24.8	20.2	16.6	45.0
50.0			26.8	27.4	26.8	24.8	24.6	22.2	22.0	20.2	16.6	50.0
55.0			12.8	23.6	23.0	21.4	22.0	19.2	19.0	19.2	16.6	55.0
60.0				20.4	19.8	19.8	19.4	17.4	16.6	16.8	16.6	60.0
65.0				17.8	17.2	18.4	17.0	16.4	15.2	15.4	15.0	65.0
70.0					15.2	16.2	15.2	15.2	14.4	14.4	13.2	70.0
75.0					13.2	14.2	13.4	13.6	13.4	12.8	11.8	75.0
80.0					9.6	12.8	11.8	12.2	12.0	11.6	10.6	80.0
85.0						11.4	10.4	11.0	10.8	10.4	9.4	85.0
90.0						10.2	9.2	10.2	10.0	9.4	8.4	90.0
95.0							8.6	9.4	9.0	8.4	7.4	95.0
100.0							8.2	8.6	8.0	7.6	6.6	100.0
105.0							7.8	7.6	7.2	6.8	6.0	105.0
110.0								7.0	6.4	6.0	5.2	110.0
115.0								6.2	5.8	5.2	4.6	115.0
120.0									5.2	4.6	4.0	120.0
125.0									4.6	4.0	3.4	125.0
130.0									4.0	3.6	2.8	130.0
135.0										3.0	2.4	135.0
140.0										2.6	2.0	140.0



11,0 m - 51,0 m
(36 ft - 167 ft)



7,2 m
(23.6 ft)



360°



11,4 t (25,100 lb)



Pounds x 1000

Feet	36.1	48.5-49.7	61-63.2	73.8-76.4	86.6-89.3	99.9-101.7	113.2-115.3	126.6-128.8	140.1-142-1	153.7-154.9	167.3	Feet
10.0	154.0	126.0	118.0									10.0
15.0	109.0	104.0	97.0	91.0								15.0
20.0	83.0	83.0	83.0	77.0	74.0	59.0						20.0
25.0	65.0	66.0	66.0	64.0	62.0	56.0	43.6					25.0
30.0		54.0	52.0	51.0	49.0	47.0	40.6	33.8	26.2			30.0
35.0		42.2	43.2	40.8	40.8	37.8	35.2	32.4	26.2	20.2	16.6	35.0
40.0		33.2	34.4	35.0	33.6	31.2	29.0	27.8	26.2	20.2	16.6	40.0
45.0			29.2	29.8	28.4	26.2	26.2	23.4	23.2	20.2	16.6	45.0
50.0			24.8	25.0	24.4	22.8	22.8	20.0	19.8	19.8	16.6	50.0
55.0			12.8	21.4	21.0	21.2	19.8	18.6	17.4	17.6	16.6	55.0
60.0				18.4	18.0	19.0	17.4	17.4	16.4	16.4	15.2	60.0
65.0				16.0	15.6	16.6	15.2	15.4	15.0	14.4	13.4	65.0
70.0					13.6	14.6	13.6	13.6	13.6	12.8	11.8	70.0
75.0					11.8	12.8	11.8	12.6	12.2	11.4	10.4	75.0
80.0					9.6	11.4	10.4	11.8	11.0	10.2	9.2	80.0
85.0						10.0	9.8	10.4	9.8	9.0	8.2	85.0
90.0						9.0	9.2	9.4	8.8	8.2	7.2	90.0
95.0							8.6	8.4	7.8	7.2	6.4	95.0
100.0							7.6	7.4	7.0	6.6	5.6	100.0
105.0							7.0	6.6	6.2	5.8	5.0	105.0
110.0								6.0	5.6	5.0	4.2	110.0
115.0								5.4	4.8	4.4	3.6	115.0
120.0									4.2	3.8	3.0	120.0
125.0									3.8	3.2	2.6	125.0
130.0									3.2	2.8	2.0	130.0
135.0										2.4		135.0
140.0										2.0		140.0

**Lifting loads > 130,000 lbs. can be lifted only with additional equipment

THIS CHART IS ONLY A GUIDE AND SHOULD NOT BE USED TO OPERATE THE CRANE.

The individual crane's load chart, operating instructions and other instructional plates must be read and understood prior to operating the crane

Load charts

Main boom



11,0 m - 51,0 m
(36 ft - 167 ft)



7,2 m
(23.6 ft)



360°



10,2 t (22,400 lb)



Pounds x 1000

Feet	36.1	48.5-49.7	61-63.2	73.8-76.4	86.6-89.3	99.9-101.7	113.2-115.3	126.6-128.8	140.1-142.1	153.7-154.9	167.3	Feet
10.0	154.0	126.0	118.0									10.0
15.0	109.0	104.0	97.0	91.0								15.0
20.0	82.0	82.0	83.0	77.0	74.0	59.0						20.0
25.0	64.0	65.0	65.0	62.0	59.0	56.0	43.6					25.0
30.0		53.0	52.0	49.0	48.0	45.0	40.6	33.8	26.2			30.0
35.0		40.2	41.4	39.2	39.0	36.0	33.6	32.0	26.2	20.2	16.6	35.0
40.0		31.8	32.8	34.0	32.2	29.6	28.2	26.4	26.0	20.2	16.6	40.0
45.0			28.2	28.4	27.0	25.0	25.4	22.2	21.8	20.2	16.6	45.0
50.0			23.6	23.8	23.2	22.8	21.8	20.0	18.8	18.8	16.6	50.0
55.0			12.8	20.2	19.8	20.4	18.8	18.6	17.4	17.6	16.4	55.0
60.0				17.4	17.0	18.0	16.4	16.4	16.0	15.4	14.2	60.0
65.0				15.0	14.6	15.8	14.4	14.4	14.4	13.6	12.4	65.0
70.0					12.8	13.8	12.8	13.4	13.0	12.0	11.0	70.0
75.0					11.0	12.0	11.2	12.4	11.6	10.6	9.6	75.0
80.0					9.6	10.6	10.4	11.0	10.4	9.4	8.4	80.0
85.0						9.4	9.8	9.8	9.2	8.4	7.4	85.0
90.0						9.0	9.0	8.8	8.2	7.6	6.6	90.0
95.0							8.0	7.8	7.4	6.6	5.8	95.0
100.0							7.2	7.0	6.4	6.0	5.0	100.0
105.0							6.4	6.2	5.6	5.2	4.4	105.0
110.0								5.4	5.0	4.6	3.8	110.0
115.0								4.8	4.4	3.8	3.2	115.0
120.0									3.8	3.4	2.6	120.0
125.0									3.4	2.8	2.2	125.0
130.0									2.8	2.4		130.0
135.0										2.0		135.0



11,0 m - 51,0 m
(36 ft - 167 ft)



7,2 m
(23.6 ft)



360°



9,1 t (20,000 lb)



Pounds x 1000

Feet	36.1	48.5-49.7	61-63.2	73.8-76.4	86.6-89.3	99.9-101.7	113.2-115.3	126.6-128.8	140.1-142.1	153.7-154.9	167.3	Feet
10.0	154.0	126.0	118.0									10.0
15.0	109.0	104.0	97.0	91.0								15.0
20.0	81.0	82.0	82.0	77.0	74.0	59.0						20.0
25.0	63.0	64.0	64.0	62.0	56.0	55.0	43.6					25.0
30.0		50.0	50.0	47.0	46.0	42.6	39.6	33.8	26.2			30.0
35.0		38.2	39.4	39.2	37.2	34.2	31.8	30.4	26.2	20.2	16.6	35.0
40.0		30.2	32.0	32.4	30.6	28.2	28.2	25.0	24.6	20.2	16.6	40.0
45.0			26.8	27.2	25.8	24.4	24.0	21.4	20.6	20.2	16.6	45.0
50.0			22.4	22.6	22.0	22.4	20.6	20.0	18.8	18.6	16.6	50.0
55.0			12.8	19.2	18.8	19.4	17.8	17.8	17.4	16.6	15.4	55.0
60.0				16.4	16.0	17.0	15.4	15.4	15.6	14.6	13.4	60.0
65.0				14.6	13.8	14.8	13.6	14.2	13.8	12.8	11.6	65.0
70.0					11.8	13.0	12.2	13.0	12.2	11.2	10.2	70.0
75.0					10.4	11.4	11.2	11.6	10.8	10.0	9.0	75.0
80.0					9.0	10.0	10.4	10.4	9.6	8.8	7.8	80.0
85.0						9.4	9.4	9.2	8.6	7.8	6.8	85.0
90.0						8.6	8.4	8.2	7.6	7.0	6.0	90.0
95.0							7.4	7.2	6.8	6.2	5.2	95.0
100.0							6.6	6.4	6.0	5.4	4.4	100.0
105.0							5.8	5.6	5.2	4.6	3.8	105.0
110.0								5.0	4.6	4.0	3.4	110.0
115.0								4.4	4.0	3.4	2.8	115.0
120.0									3.4	2.8	2.2	120.0
125.0									2.8	2.4		125.0
130.0									2.4	2.0		130.0

*Lifting loads > 130,000 lbs. can be lifted only with additional equipment

THIS CHART IS ONLY A GUIDE AND SHOULD NOT BE USED TO OPERATE THE CRANE.

The individual crane's load chart, operating instructions and other instructional plates must be read and understood prior to operating the crane

Load charts

Main boom



11,0 m - 51,0 m
(36 ft - 167 ft)



7,2 m
(23.6 ft)



360°



8 t (17,600 lb)



Pounds x 1000

Feet	36.1	48.5-49.7	61-63.2	73.8-76.4	86.6-89.3	99.9-101.7	113.2-115.3	126.6-128.8	140.1-142-1	153.7-154.9	167.3	Feet
10.0	154.0	126.0	118.0									10.0
15.0	109.0	104.0	97.0	91.0								15.0
20.0	80.0	81.0	81.0	77.0	74.0	59.0						20.0
25.0	63.0	63.0	61.0	59.0	54.0	53.0	43.6					25.0
30.0		48.0	48.0	44.0	44.0	40.6	37.6	33.8	26.2			30.0
35.0		36.4	37.6	37.6	35.4	32.6	30.4	28.8	26.2	20.2	16.6	35.0
40.0		29.0	31.0	30.8	29.0	26.6	27.0	23.6	23.2	20.2	16.6	40.0
45.0			25.4	25.8	24.4	24.4	22.8	21.4	20.2	19.6	16.6	45.0
50.0			21.2	21.4	20.8	21.2	19.4	19.4	18.8	18.0	16.6	50.0
55.0			12.8	18.2	17.8	18.4	16.8	16.8	16.8	15.6	14.4	55.0
60.0				15.6	15.0	16.0	14.6	15.4	14.6	13.6	12.4	60.0
65.0				14.4	13.0	14.0	13.2	13.8	12.8	12.0	10.8	65.0
70.0					11.2	12.2	12.2	12.2	11.4	10.4	9.4	70.0
75.0					9.6	10.6	11.2	10.8	10.0	9.2	8.2	75.0
80.0					8.4	10.0	10.0	9.6	9.0	8.2	7.2	80.0
85.0						9.0	8.8	8.6	8.0	7.2	6.2	85.0
90.0						8.0	7.8	7.6	7.0	6.4	5.4	90.0
95.0							6.8	6.6	6.2	5.6	4.6	95.0
100.0							6.0	5.8	5.4	4.8	4.0	100.0
105.0							5.4	5.2	4.6	4.2	3.4	105.0
110.0								4.6	4.0	3.6	2.8	110.0
115.0								4.0	3.4	3.0	2.2	115.0
120.0									3.0	2.4	1.8	120.0
125.0										2.4	2.0	125.0
130.0										2.0		130.0



11,0 m - 51,0 m
(36 ft - 167 ft)



7,2 m
(23.6 ft)



360°



6,8 t (14,900 lb)



Pounds x 1000

Feet	36.1	48.5-49.7	61-63.2	73.8-76.4	86.6-89.3	99.9-101.7	113.2-115.3	126.6-128.8	140.1-142-1	153.7-154.9	167.3	Feet
10.0	154.0	126.0	118.0									10.0
15.0	108.0	104.0	97.0	91.0								15.0
20.0	79.0	80.0	80.0	75.0	71.0	59.0						20.0
25.0	61.0	62.0	58.0	56.0	54.0	50.0	43.6					25.0
30.0		45.0	45.0	44.0	41.8	38.4	35.6	33.8	26.2			30.0
35.0		34.6	35.8	35.6	33.6	30.8	30.4	27.2	26.2	20.2	16.6	35.0
40.0		27.6	29.4	29.2	27.4	26.4	25.6	23.2	21.8	20.2	16.6	40.0
45.0			24.0	24.4	23.0	23.4	21.4	21.2	20.2	19.6	16.6	45.0
50.0			20.0	20.2	19.6	20.0	18.2	18.2	18.2	17.0	15.6	50.0
55.0			12.6	17.2	16.6	17.2	15.6	16.6	15.8	14.6	13.4	55.0
60.0				15.6	14.2	15.0	14.2	14.6	13.8	12.8	11.6	60.0
65.0				13.4	12.0	13.2	13.2	12.8	12.0	11.2	10.0	65.0
70.0					10.4	11.4	12.0	11.4	10.6	9.8	8.6	70.0
75.0					9.2	10.6	10.6	10.0	9.4	8.6	7.6	75.0
80.0					7.6	9.4	9.2	9.0	8.2	7.4	6.4	80.0
85.0						8.4	8.2	7.8	7.2	6.6	5.6	85.0
90.0						7.4	7.2	7.0	6.4	5.8	4.8	90.0
95.0							6.2	6.0	5.6	5.0	4.0	95.0
100.0							5.6	5.4	4.8	4.4	3.4	100.0
105.0							4.8	4.6	4.2	3.6	2.8	105.0
110.0								4.0	3.6	3.0	2.4	110.0
115.0								3.4	3.0	2.6	1.8	115.0
120.0									2.6	2.0		120.0
125.0										2.0		125.0

**Lifting loads > 130,000 lb can be lifted only with additional equipment

THIS CHART IS ONLY A GUIDE AND SHOULD NOT BE USED TO OPERATE THE CRANE.

The individual crane's load chart, operating instructions and other instructional plates must be read and understood prior to operating the crane

Load charts

Main boom



11,0 m - 51,0 m
(36 ft - 167 ft)



7,2 m
(23.6 ft)



360°



5,7 t (12,500 lb)



Pounds x 1000

Feet	36.1	48.5-49.7	61-63.2	73.8-76.4	86.6-89.3	99.9-101.7	113.2-115.3	126.6-128.8	140.1-142.1	153.7-154.9	167.3	Feet
10.0	154.0	126.0	118.0									10.0
15.0	107.0	104.0	97.0	91.0								15.0
20.0	78.0	79.0	79.0	71.0	68.0	59.0						20.0
25.0	58.0	59.0	55.0	53.0	52.0	48.0	43.6					25.0
30.0		43.2	42.8	42.4	39.8	36.4	33.6	32.0	26.2			30.0
35.0		32.6	35.2	33.8	31.8	29.0	29.2	25.6	25.0	20.2	16.6	35.0
40.0		26.0	27.8	27.6	26.0	26.2	24.0	23.2	21.6	20.2	16.6	40.0
45.0			22.6	23.0	21.6	22.0	20.2	20.0	19.8	18.6	16.6	45.0
50.0			18.8	19.0	18.2	18.8	17.0	17.8	17.0	16.0	14.6	50.0
55.0			12.6	16.8	15.6	16.2	15.4	15.6	14.8	13.6	12.4	55.0
60.0				14.6	13.2	14.0	14.2	13.6	12.8	11.8	10.8	60.0
65.0				12.6	11.2	12.2	12.6	12.0	11.2	10.2	9.2	65.0
70.0					9.8	11.4	11.2	10.6	9.8	9.0	8.0	70.0
75.0					9.2	10.0	9.8	9.4	8.6	7.8	6.8	75.0
80.0					7.0	8.8	8.6	8.2	7.6	6.8	5.8	80.0
85.0						7.8	7.4	7.2	6.6	5.8	5.0	85.0
90.0						6.8	6.6	6.4	5.8	5.0	4.2	90.0
95.0							5.8	5.4	5.0	4.4	3.4	95.0
100.0							5.0	4.8	4.4	3.8	2.8	100.0
105.0							4.4	4.2	3.6	3.2	2.4	105.0
110.0								3.6	3.0	2.6	1.8	110.0
115.0								3.0	2.6	2.0		115.0
120.0									2.0			120.0

**Lifting loads > 130,000 lb can be lifted only with additional equipment

THIS CHART IS ONLY A GUIDE AND SHOULD NOT BE USED TO OPERATE THE CRANE.

The individual crane's load chart, operating instructions and other instructional plates must be read and understood prior to operating the crane

Load charts

Main boom



11,0 m - 51,0 m
(36 ft - 167 ft)



7,2 m
(23.6 ft)



360°



4,5 t (9900 lb)



Pounds x 1000

Feet	36.1	48.5-49.7	61-63.2	73.8-76.4	86.6-89.3	99.9-101.7	113.2-115.3	126.6-128.8	140.1-142-1	153.7-154.9	167.3	Feet
10.0	154.0	126.0	118.0									10.0
15.0	106.0	104.0	97.0	91.0								15.0
20.0	77.0	78.0	75.0	67.0	64.0	59.0						20.0
25.0	55.0	56.0	54.0	50.0	49.0	45.0	41.4					25.0
30.0		40.8	40.4	40.2	37.6	34.4	31.6	30.0	26.2			30.0
35.0		31.4	33.2	32.0	29.8	28.8	27.6	25.0	23.4	20.2	16.6	35.0
40.0		24.4	26.2	26.0	24.4	24.6	22.6	22.4	21.6	19.6	16.6	40.0
45.0			21.2	21.6	20.2	20.8	18.8	19.4	18.6	17.4	16.0	45.0
50.0			17.6	18.2	17.0	17.6	16.8	17.0	16.0	14.8	13.6	50.0
55.0			11.8	16.0	14.6	15.2	15.4	14.6	13.8	12.6	11.6	55.0
60.0				13.6	12.2	13.2	13.4	12.6	11.8	11.0	9.8	60.0
65.0				11.6	10.6	12.2	11.6	11.0	10.4	9.4	8.4	65.0
70.0					9.8	10.6	10.2	9.8	9.0	8.2	7.2	70.0
75.0					9.0	9.2	9.0	8.6	7.8	7.0	6.0	75.0
80.0					6.2	8.2	7.8	7.6	6.8	6.0	5.2	80.0
85.0						7.0	6.8	6.6	6.0	5.2	4.4	85.0
90.0						6.2	6.0	5.8	5.2	4.4	3.6	90.0
95.0							5.2	5.0	4.4	3.8	3.0	95.0
100.0							4.4	4.2	3.8	3.2	2.4	100.0
105.0							3.8	3.6	3.2	2.6	1.8	105.0
110.0								3.0	2.6	2.0		110.0
115.0								2.6	2.0			115.0



11,0 m - 51,0 m
(36 ft - 167 ft)



7,2 m
(23.6 ft)



360°



3,4 t (7400 lb)



Pounds x 1000

Feet	36.1	48.5-49.7	61-63.2	73.8-76.4	86.6-89.3	99.9-101.7	113.2-115.3	126.6-128.8	140.1-142-1	153.7-154.9	167.3	Feet
10.0	154.0	126.0	118.0									10.0
15.0	105.0	104.0	97.0	91.0								15.0
20.0	77.0	77.0	71.0	64.0	61.0	59.0						20.0
25.0	52.0	54.0	52.0	50.0	47.0	42.6	39.0					25.0
30.0		38.6	40.0	38.0	35.6	32.4	30.8	28.2	26.2			30.0
35.0		29.6	31.4	30.2	28.2	28.4	26.0	25.0	23.0	20.2	16.6	35.0
40.0		23.0	24.8	24.6	23.0	23.2	21.2	21.0	20.8	19.4	16.6	40.0
45.0			20.0	20.4	19.0	19.4	18.4	18.6	17.6	16.4	15.0	45.0
50.0			16.4	17.8	16.0	16.4	16.6	15.8	14.8	13.8	12.6	50.0
55.0			10.8	15.0	13.6	14.2	14.4	13.6	12.8	11.8	10.6	55.0
60.0				12.8	11.6	13.2	12.4	11.8	11.0	10.0	9.0	60.0
65.0				10.8	10.6	11.4	10.8	10.2	9.6	8.6	7.6	65.0
70.0					9.6	10.0	9.6	9.0	8.2	7.4	6.4	70.0
75.0					8.2	8.6	8.4	7.8	7.2	6.4	5.4	75.0
80.0					5.6	7.4	7.2	6.8	6.2	5.4	4.6	80.0
85.0						6.4	6.2	6.0	5.4	4.6	3.8	85.0
90.0						5.6	5.4	5.2	4.6	4.0	3.0	90.0
95.0							4.6	4.4	4.0	3.2	2.4	95.0
100.0							4.0	3.8	3.2	2.6	1.8	100.0
105.0							3.4	3.2	2.6	2.2		105.0
110.0								2.6	2.2			110.0
115.0								2.2				115.0

**Lifting loads > 130,000 lb can be lifted only with additional equipment

THIS CHART IS ONLY A GUIDE AND SHOULD NOT BE USED TO OPERATE THE CRANE.

The individual crane's load chart, operating instructions and other instructional plates must be read and understood prior to operating the crane

Load charts

Main boom



11,0 m - 51,0 m
(36 ft - 167 ft)



7,2 m
(23.6 ft)



360°



0,5 t (1100 lb)



Pounds x 1000

Feet	36.1	48.5-49.7	61-63.2	73.8-76.4	86.6-89.3	99.9-101.7	113.2-115.3	126.6-128.8	140.1-142.1	153.7-154.9	167.3	Feet
10.0	153.0	126.0	118.0									10.0
15.0	102.0	103.0	97.0	91.0								15.0
20.0	70.0	67.0	61.0	58.0	55.0	50.0						20.0
25.0	43.8	46.0	46.0	43.4	40.0	36.2	33.0					25.0
30.0		33.4	34.0	32.4	30.2	30.0	27.4	26.8	24.0			30.0
35.0		25.0	26.6	25.4	23.6	24.0	22.4	22.6	21.2	19.6	16.6	35.0
40.0		19.0	20.8	21.6	19.0	19.4	19.6	18.6	17.4	16.0	14.6	40.0
45.0			16.6	18.0	15.6	16.8	16.4	15.4	14.4	13.4	12.0	45.0
50.0			13.6	14.8	13.8	14.6	13.8	13.0	12.2	11.2	10.0	50.0
55.0			9.6	12.4	12.6	12.4	11.8	11.0	10.2	9.4	8.2	55.0
60.0				10.4	10.6	10.8	10.0	9.4	8.6	7.8	6.8	60.0
65.0				8.8	9.0	9.2	8.6	8.2	7.4	6.6	5.6	65.0
70.0					7.6	8.0	7.4	7.0	6.2	5.4	4.6	70.0
75.0					6.4	6.8	6.4	6.0	5.4	4.6	3.6	75.0
80.0					3.8	5.8	5.4	5.2	4.4	3.8	2.8	80.0
85.0						4.8	4.6	4.4	3.8	3.0	2.2	85.0
90.0						4.2	3.8	3.6	3.0	2.4		90.0
95.0							3.2	3.0	2.4	1.8		95.0
100.0							2.6	2.4	2.0			100.0
105.0							2.2	1.8				105.0

**Lifting loads > 130,000 lb can be lifted only with additional equipment

THIS CHART IS ONLY A GUIDE AND SHOULD NOT BE USED TO OPERATE THE CRANE.

The individual crane's load chart, operating instructions and other instructional plates must be read and understood prior to operating the crane

Working range

Swingaway extension



11,0 m - 51,0 m (36 ft - 167 ft)



8,7 m - 15 m (28.5 ft - 49.2 ft)



7,2 m (23.6 ft)



360°

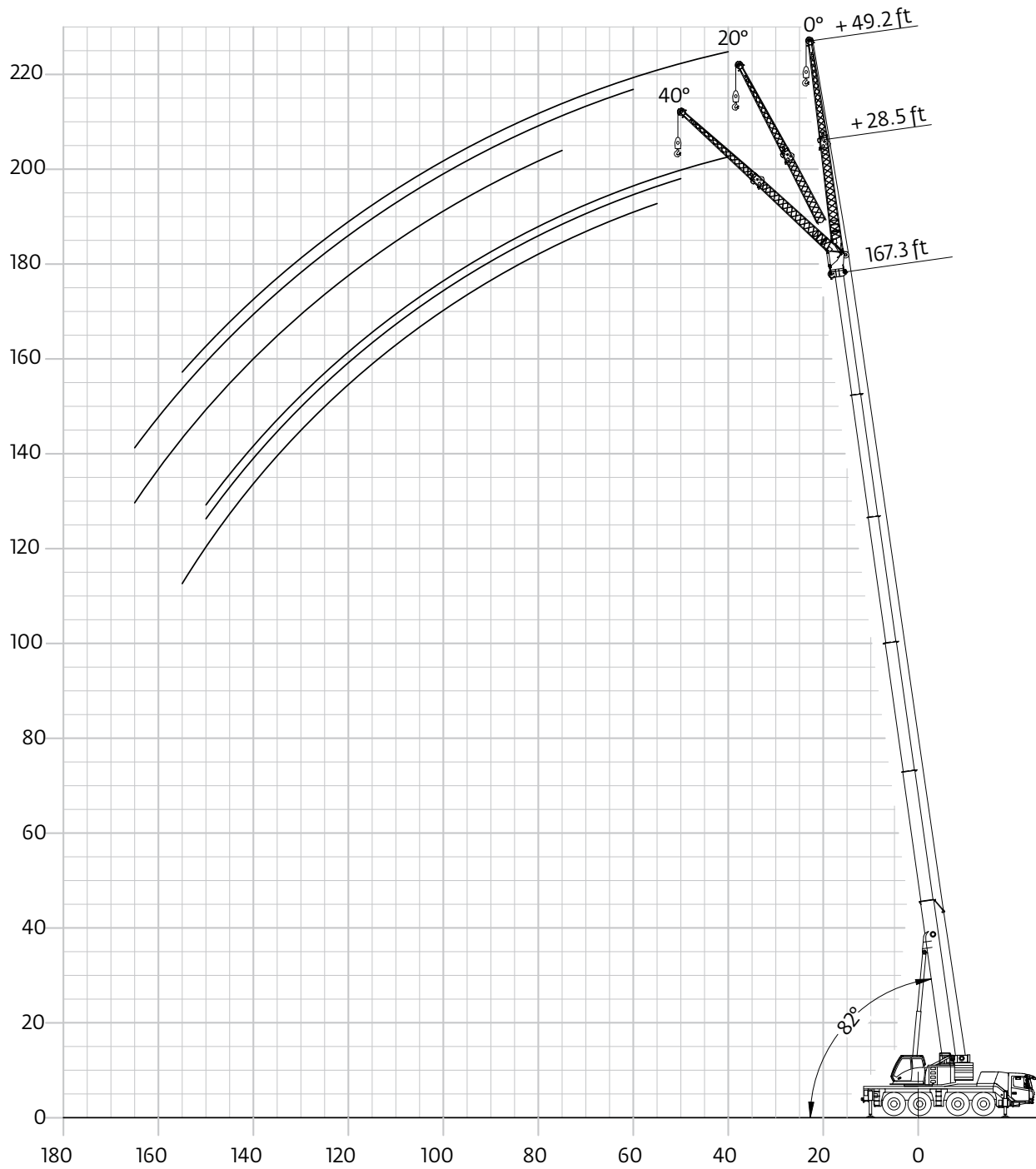

Load charts

Swingaway extension



11,0 m - 51,0 m
(36 ft - 167 ft)



8,7 m (28.5 ft)



7,2 m
(23.6 ft)



360°



14,8 t
(32,600 lb)



Pounds x 1000

Feet	36.1 28.5			113.2 - 115.3 28.5			153.7 - 154.9 28.5			167.3 28.5			Feet
	0°	0°-20°	20°-40°	0°	0°-20°	20°-40°	0°	0°-20°	20°-40°	0°	0°-20°	20°-40°	
Radius													Radius
10.0	22.0												10.0
15.0	18.4												15.0
20.0	15.4	11.2											20.0
25.0	13.2	10.0	8.4	17.6									25.0
30.0	11.6	9.0	7.8	17.2									30.0
35.0	10.2	8.4	7.6	16.4	10.8		11.4						35.0
40.0	9.2	7.8	7.2	15.4	10.2	8.2	11.4			9.4			40.0
45.0	8.4	7.4	7.2	14.4	9.8	8.0	11.4	9.4		9.4			45.0
50.0	7.6	7.2		13.6	9.4	7.8	11.4	9.2	7.8	9.4	9.0		50.0
55.0	7.0			12.8	9.2	7.6	11.4	8.8	7.6	9.4	8.8	7.4	55.0
60.0				12.0	8.8	7.6	11.4	8.6	7.6	9.4	8.6	7.4	60.0
65.0				11.4	8.6	7.4	11.2	8.4	7.4	9.4	8.4	7.4	65.0
70.0				10.8	8.4	7.4	11.0	8.2	7.4	9.4	8.2	7.2	70.0
75.0				10.2	8.0	7.2	10.6	8.0	7.2	9.4	8.0	7.2	75.0
80.0				9.8	7.8	7.2	10.2	8.0	7.2	9.4	8.0	7.2	80.0
85.0				9.4	7.6	7.2	9.2	7.8	7.2	9.4	7.8	7.0	85.0
90.0				9.0	7.6	7.2	8.2	7.6	7.0	8.4	7.6	7.0	90.0
95.0				7.8	7.4	7.2	7.4	7.4	7.0	7.6	7.6	7.0	95.0
100.0				7.0	7.0	7.2	6.6	7.4	7.0	6.8	6.8	7.0	100.0
105.0				6.0	6.0	6.4	5.8	7.0	6.2	6.0	6.0	6.4	105.0
110.0				5.2	5.2	5.6	5.2	6.2	5.6	5.4	5.4	5.8	110.0
115.0				4.6	4.6		4.6	5.6	5.0	4.8	4.8	5.2	115.0
120.0				4.0	4.0		4.0	5.0	4.4	4.2	4.2	4.6	120.0
125.0				3.4	3.4		3.4	4.4	3.8	3.6	3.6	4.0	125.0
130.0				2.8	2.8		2.8	4.0	3.2	3.2	3.2	3.6	130.0
135.0							2.4	3.4	2.6	2.6	2.6	3.0	135.0
140.0							1.8	3.0	2.2	2.2	2.2	2.6	140.0
145.0							1.4	2.6		1.8	1.8	2.0	145.0
150.0								2.2		1.4	1.4	1.6	150.0
155.0								1.8					155.0
160.0								1.4					160.0
165.0													165.0

Load charts

Swingaway extension



11,0 m - 51,0 m
(36 ft - 167 ft)



15 m (49.2 ft)



7,2 m
(23.6 ft)



360°



14,8 t
(32,600 lb)



Pounds x 1000

Feet	36.1			113.2 - 115.3			153.7 - 154.9			167.3			Feet
	0°	0°-20°	20°-40°	0°	0°-20°	20°-40°	0°	0°-20°	20°-40°	0°	0°-20°	20°-40°	
Radius													Radius
10.0	11.0												10.0
15.0	11.0												15.0
20.0	10.0												20.0
25.0	8.6												25.0
30.0	7.6	5.8		9.0									30.0
35.0	6.8	5.4		9.0									35.0
40.0	6.0	5.0	4.2	8.8			6.2			5.6			40.0
45.0	5.6	4.6	4.0	8.4			6.2			5.6			45.0
50.0	5.0	4.4	3.8	7.8	5.4		6.2			5.6			50.0
55.0	4.6	4.0	3.6	7.4	5.2		6.2			5.6			55.0
60.0	4.2	3.8	3.6	7.0	5.0	4.0	6.2	5.0		5.6	5.0		60.0
65.0	4.0	3.6	3.4	6.6	4.8	4.0	6.2	4.8		5.6	4.8		65.0
70.0	3.8	3.6		6.2	4.6	3.8	6.0	4.6	3.8	5.6	4.6		70.0
75.0	3.6	3.4		6.0	4.4	3.8	6.0	4.6	3.8	5.6	4.6	3.8	75.0
80.0				5.6	4.4	3.8	5.8	4.4	3.8	5.6	4.4	3.8	80.0
85.0				5.4	4.2	3.6	5.6	4.4	3.6	5.6	4.4	3.8	85.0
90.0				5.2	4.2	3.6	5.4	4.2	3.6	5.4	4.2	3.6	90.0
95.0				5.0	4.0	3.6	5.2	4.2	3.6	5.2	4.2	3.6	95.0
100.0				4.8	4.0	3.6	5.0	4.0	3.6	5.2	4.0	3.6	100.0
105.0				4.6	3.8	3.6	4.8	4.0	3.6	5.0	4.0	3.6	105.0
110.0				4.4	3.8	3.4	4.8	3.8	3.4	4.8	4.0	3.6	110.0
115.0				4.2	3.6	3.4	4.6	3.8	3.4	4.6	3.8	3.4	115.0
120.0				4.0	3.6	3.4	4.4	3.8	3.4	4.6	3.8	3.4	120.0
125.0				4.0	3.6	3.4	4.4	3.6	3.4	4.0	3.8	3.4	125.0
130.0				3.6	3.4	3.4	4.2	3.6	3.4	3.6	3.6	3.4	130.0
135.0				3.2	3.2		4.0	3.6	3.4	3.2	3.2	3.4	135.0
140.0				2.8	2.8		3.4	3.4	3.4	2.8	2.8	3.4	140.0
145.0				2.4	2.4		3.0	3.0	3.4	2.4	2.4	2.8	145.0
150.0				2.0	2.0		2.6	2.6	3.0	2.0	2.0	2.4	150.0
155.0							2.2	2.2	2.6	1.6	1.6	2.0	155.0
160.0							2.0	2.0	2.2			1.6	160.0
165.0							1.6	1.6	2.0			1.4	165.0
170.0							1.2	1.2					170.0

Load charts

Swingaway extension



11,0 m - 51,0 m
(36 ft - 167 ft)



21 m (68.9 ft)



7,2 m
(23.6 ft)



360°



14,8 t
(32,600 lb)



Pounds x 1000

Feet	36.1 68.9 0°-20° 20°-40°			113.2 - 115.3 68.9 0°-20° 20°-40°			153.7 - 154.9 68.9 0°-20° 20°-40°			167.3 68.9 0°-20° 20°-40°			Feet
	0°	0°-20°	20°-40°	0°	0°-20°	20°-40°	0°	0°-20°	20°-40°	0°	0°-20°	20°-40°	
Radius													Radius
10.0													10.0
15.0	11.0												15.0
20.0	10.8												20.0
25.0	9.8												25.0
30.0	8.8	6.2		7.8									30.0
35.0	7.8	5.8		7.8									35.0
40.0	7.2	5.4	4.4	7.6			5.0			4.6			40.0
45.0	6.4	5.0	4.2	7.6			5.0			4.6			45.0
50.0	6.0	4.8	4.0	7.6	5.2		5.0			4.6			50.0
55.0	5.6	4.4	3.8	7.4	5.0		5.0			4.6			55.0
60.0	5.2	4.2	3.8	7.2	4.8	4.0	5.0	4.8		4.6			60.0
65.0	4.8	4.0	3.6	6.8	4.6	4.0	5.0	4.6		4.6			65.0
70.0	4.6	4.0	3.6	6.4	4.6	4.0	5.0	4.6		4.6	4.4		70.0
75.0	4.2	3.8	3.6	6.2	4.4	3.8	5.0	4.4	3.8	4.6	4.4		75.0
80.0	4.0	3.6	3.4	6.0	4.4	3.8	5.0	4.4	3.8	4.6	4.4	3.8	80.0
85.0	3.8	3.6	3.4	5.6	4.2	3.8	5.0	4.2	3.6	4.6	4.2	3.6	85.0
90.0	3.6	3.4		5.4	4.0	3.6	5.0	4.2	3.6	4.6	4.2	3.6	90.0
95.0	3.4	3.4		5.2	4.0	3.6	5.0	4.2	3.6	4.6	4.2	3.6	95.0
100.0				5.0	4.0	3.6	5.0	4.0	3.6	4.6	4.0	3.6	100.0
105.0				4.8	3.8	3.6	4.8	4.0	3.6	4.6	4.0	3.6	105.0
110.0				4.6	3.8	3.6	4.8	3.8	3.4	4.6	3.8	3.4	110.0
115.0				4.6	3.6	3.4	4.6	3.8	3.4	4.6	3.8	3.4	115.0
120.0				4.4	3.6	3.4	4.4	3.8	3.4	4.4	3.8	3.4	120.0
125.0				4.2	3.6	3.4	4.4	3.6	3.4	3.8	3.8	3.4	125.0
130.0				4.0	3.6	3.4	4.2	3.6	3.4	3.4	3.4	3.4	130.0
135.0				3.4	3.4	3.4	3.8	3.6	3.4	3.0	3.0	3.4	135.0
140.0				3.0	3.4	3.4	3.4	3.4	3.4	2.6	2.6	3.2	140.0
145.0				2.6	3.4	3.0	3.0	3.0	3.4	2.2	2.2	2.8	145.0
150.0				2.2	3.2	2.4	2.6	2.6	3.0	1.8	1.8	2.4	150.0
155.0				1.8	3.0		2.2	2.2	2.6	1.6	1.6	2.0	155.0
160.0				1.4	3.0		1.8	1.8	2.4			1.6	160.0
165.0					2.8		1.6	1.6	2.0			1.4	165.0
170.0									1.6				170.0

The lifting capacities correspond to ASME B30.5

The lifting capacities likewise fulfill the requirements of ISO 4305 with regard to stability.

The lifting capacities are given in pounds x 1000.

Lifting capacity = Payload + weight of hook block and suspending device.

The lifting capacities for the main boom only apply with the jib dismantled.

Lifting capacities greater than 130,000 lb require additional equipment.

Lifting capacities greater than 165,000 lb require special equipment.

The right is reserved to modify the load-carrying capacities.

Note: The details in this brochure serve only as general information. The determinant values for the operation of the crane are the lifting capacity tables belonging to it and the operating instructions.

Lifting capacities are indicated by boom length for different levels of extension. The actual boom length will be in accordance with the selected configuration for boom extension.

Specifications

Superstructure



Boom

11,0 m to 51,0 m (36 ft - 167 ft) six section TWIN-LOCK™ boom. Maximum tip height 54,0 m (177 ft).



Boom elevation

One cylinder with safety valve, boom angle from -3,0° to +82°.



Load moment and independent anti-two block system

Load moment and independent anti-two block system with audio visual warning and control lever lock-out. These systems provide graphic display of boom angle, length, radius, tip height, relative load moment, maximum permissible load, load indication and warning of impending two-block condition with lock-out hoist function.



Cab

Aluminium, full vision, tilting (approx. 20°), safety glass, adjustable operator's seat with suspension (optional), engine-independent heater. Armrest integrated crane controls. Ergonomically arranged instrumentation and crane operating controls.



Slewing

Two slewing gears with axial piston motors, planetary gears, automatic break.



Counterweight

14,8 t (16.3 USt), consisting of various sections (14,8 t [16.3 USt]) within 2,55 m [8.4 ft] vehicle width). Hydraulic removal system.



Hydraulic system

Two separate circuits, 1 axial piston variable displacement pump with electronic power limiting control and 1 axial piston variable displacement pump for slewing.

Thermostatically controlled oil cooler. Tank capacity: 450 l (119 gallon).



Control system

Full electronic control of all crane movements using electrical control levers with automatic reset to zero. Integrated with the RCL and engine management system by CAN-BUS. Crane Control System (CCS) with system with graphic display.



Hoist

Axial piston motor with planetary gear and brake. Drum rotation indicator. IR - Hoist camera with light.

* Optional equipment

- Bi-fold swingaway, 8,7 m (28.5 ft)/15 m (49 ft) with hydraulic offset and luffing under load (0°-40°), controlled from the crane cab.
- Bi-fold swingaway, 8,7 m (28.5 ft)/15 m (49 ft) (manual offset 0°, 20°, 40°).
- Lattice extension, 21 m (69 ft)- includes 6 m (19.7 ft) fixed non-offsettable section plus 8,7 m (28.5 ft)/15 m (49 ft) swingaway (see above).
- Auxiliary hoist

Carrier



Chassis

Special 4-axle chassis, all-welded torsion-resistant box type construction in high strength steel.



Outriggers

4 double hydraulically telescoping beams with vertical cylinders and outrigger pads. Independent horizontal and vertical movement control on each side of the carrier and from the operators cab. Electronic level indicator with automatic levelling system.



Engine

Mercedes Benz OM470LA, diesel, 6 cylinders, water cooled, turbocharged, 320 kW (430 hp) at 1700 rpm (80/1269 EWG fan loose). Max. torque: 2100 Nm at 1300 rpm. Fuel tank: 200 l + 200 l (52.8 gal + 52.8 gal)

Engine emission: Euromot 5 / EPA / CARB Tier 4 final (non road) - optional Euromot 3a / EPA / CARB Tier 3 (non road).



Transmission

Mercedes G 280-16 gears forward and 2 reverse. 2-stage transfer case with longitudinal differential lock.



Drive/Steer

8 x 6 x 8.



Axle lines

4 axle lines, axle lines 1, 2, 3 and 4 steered, axle line 1, 3 and 4 driven.



Suspension

MEGATRAK®. All wheels with independent hydropneumatic suspension and hydraulic lockout. Longitudinal and transverse level control with automatic on highway levelling system. Range +170 mm/-126 mm (+6.7 in / -5.1 in). Active suspension control on outrigger control units.



Tires

Eight tires, 385/95 R25 (14.00 R25).



Steering

Dual circuit, hydraulic power assisted steering with emergency steering pump. Axle lines 1, 2 and 4 steer on highway. Separate electronic hydraulic (steer by wire) steering of the 3rd, and 4th axle line for all wheel steering and crabbing.



Brakes

Service brake: pneumatic dual circuit drum brakes acting on all wheels, air dryer. Permanent brake: exhaust brake and constant throttle brake. Parking brake: pneumatically operated spring-loaded brake acting on axle lines 2, 3 and 4.



Driver's Cab

2-mandesign, safety glass, driver seat with pneumatic suspension, engine-independent diesel air heater incl. 24 h timer. Complete instrumentation and driving controls. Air condition. 12 V plug. Two rotating beacons. Fire extinguisher.



Electrical system

Three-phase alternator 28 V/150A, 2 batteries 12 V/180 Ah. Lighting system and signals 24 V.

* Optional equipment

- 8 x 8 x 8
- Eight tires, size 445/95 R25 (16.00 R25) - Vehicle width 2,75 m (9.02 ft)
- Eight tires, size 525/80 R25 (20.5 R25) - Vehicle width 2,88 m (9.5 ft)
- Folding bunk bed in carrier cab
- Secondary water retarder
- Reverse camera system

*Denotes optional equipment.

Symbols glossary



Axles



Counterweight



Main hoist



Outriggers



Axle load



Crane functions



Auxiliary hoist



Radius



Boom



Crane travel



Hookblock / Capacity



Slewing/
Working range



Boom elevation



Drive/Steer



Hydraulic system



Speed



Boom telescoping



Electrical system



Lattice extension



Suspension



Brakes



Engine



Lattice extension (luff-
ing)



Transmission / Gear



Cab



Free on wheels



Luffing Jib



mp/h
Travel speed



Carrier frame



Gradeability



Low range



Tires



Hose reel



Swing-Away



Dolly



Storage box +
rigging gear



Weight per axle in kg



Driveline



Brackets

The Manitowoc Company, Inc.

Regional headquarters

Americas

Milwaukee, Wisconsin, USA

Tel: +1 414 760 4600

Shady Grove, Pennsylvania, USA

Tel: +1 717 597 8121

Europe and Africa

Dardilly, France - TOWERS

Tel: +33 (0) 4 72 18 20 20

Wilhelmshaven, Germany - MOBILE

Tel: +49 (0) 4421 294 0

APAC

Shanghai, China

Tel: +86 21 6457 0066

Singapore

Tel: +65 6264 1188

Middle East and India

Dubai, UAE

Tel: +971 4 8862677

This document is non-contractual. Constant improvement and engineering progress make it necessary that we reserve the right to make specification, equipment, and price changes without notice. Illustrations shown may include optional equipment and accessories and may not include all standard equipment.

