

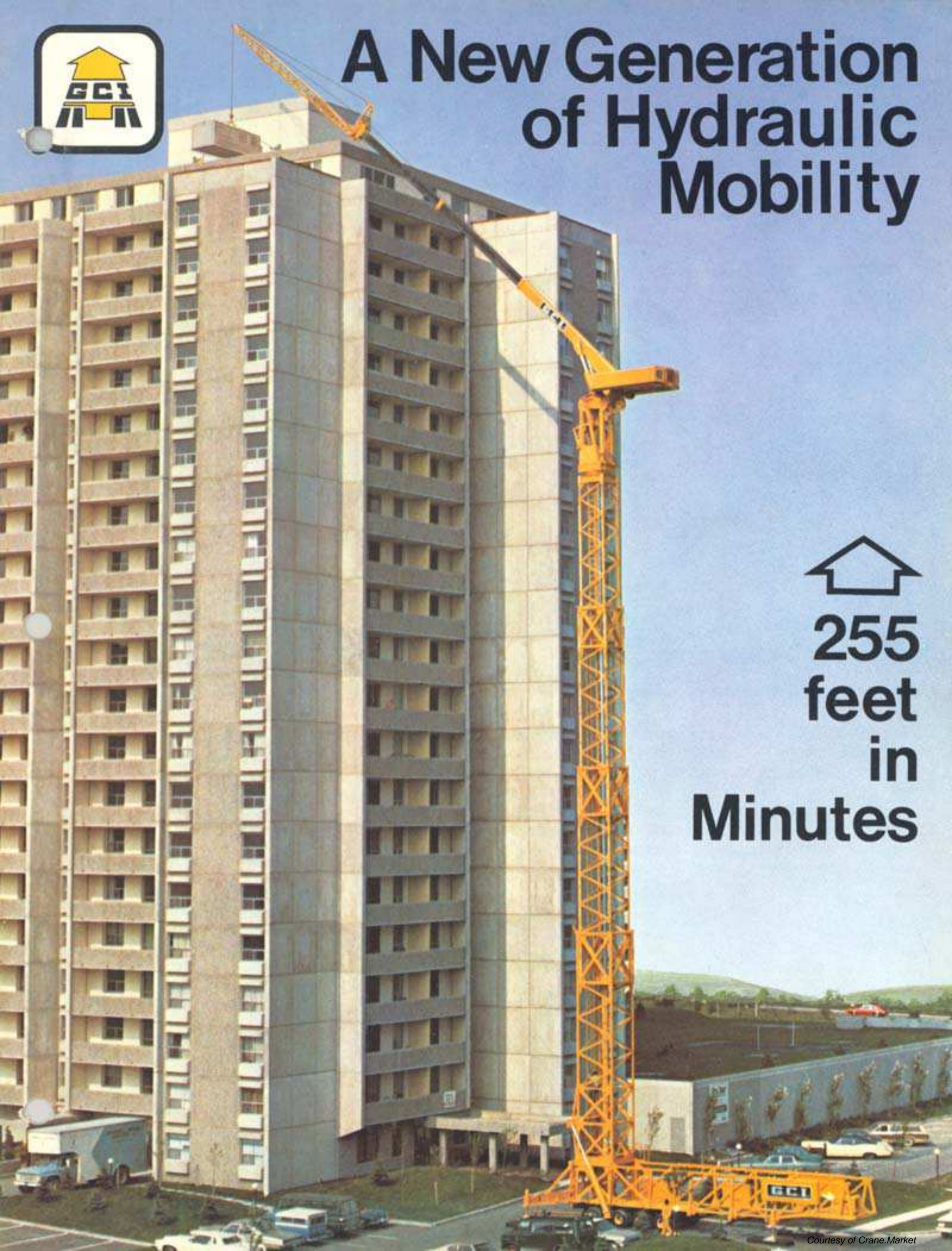

# A New Generation of Hydraulic Mobility



**255  
feet  
in  
Minutes**







# Introducing ... the GCI 5400 Mobile Hydraulic Crane



The 5400 is a completely mobile self-erecting hydraulic crane. In tractor trailer configuration it travels at a highway speed of 50 mph. The 40' jib, blocks and all rigging are mounted on the crane. Once outriggers are set, the main mast erects hydraulically from horizontal to vertical position and telescopes to operational height in minutes.

255' tip height at 75°

115' reach at 140°

80' telescoping boom

140' telescoping main mast

lifts 60,000 lbs. at 170' — 20,000 lbs. at 217'

Self-erecting hydraulic mast rises to first operating position.

Outriggers set. Crane ready to erect.



Courtesy of Crane Market



# Check these features:

- COMPLETELY SELF CONTAINED tractor trailer configuration.
- Hydraulic erection of main mast REDUCES COSTS for set up.
- Ideal for work in CONFINED SPACES where height is essential.
- Sets up 9 feet from structure.
- FAST ERECTION: 217' in 16 minutes, 255' in 45 minutes.
- The 5400 is designed for SAFETY and SPEED, to get in, get the job done and get out quickly.

## 4 WORKING HEIGHTS

Mast Height 140'  
Boom Tip 217'

HIGH PRODUCTION  
VISIBILITY from  
turntable mounted cab.

lifts 4000 lbs. 75' from centre of rotation

lifts 1300 lbs. 115' from centre of rotation

Mast Height 112'  
Boom Tip 190'

Mast Height 85'  
Boom Tip 163'

Mast Height 63'  
Boom Tip 140'

## NOTE:

The 5400 has a CLIMBING CAPACITY CHART. Lifting capacity remains constant at all four operational heights.



# SPECIFICATIONS

## UPPER DECK

**BOOM** - Grove three section boom 32 ft. - 80 ft. Full powered.

**BOOM ELEVATION** - Twin double acting hydraulic cylinders with integral holding valves.

**JIB** - 40 ft. lattice jib, gantry, guy ropes and backstops included.

**CONTROLS** - Infinite variable control on all functions. Two interchangeable control consoles.

One remote with 165 ft. of cable, one mounted in operator's cab. All control valves are electric over hydraulic.

Independent simultaneous control of three crane functions.

**ELECTRIC** - 24 volt system.

### HYDRAULIC SYSTEM:

**PUMPS** - 3 section gear type. Driven by upper engine. Total capacity - 144 gpm.

**POWER DISTRIBUTION** - Swing - 10 gpm 1450 psi  
Hoist - 84 gpm 2500 psi. Boom elevation, telescope, upper deck tilt cylinders - 50 gpm 2500 psi.

**FILTER** - Return line type full flow with bypass protection, replaceable cartridges.

**OIL COOLER** - Full flow fin and tube type. Oil to air on 85 gpm pump.

**RESERVOIR** - 150 U.S. gallons.

## UNDERCARRIAGE

### HYDRAULIC SYSTEM:

**PUMP** - Single pump gear type driven by lower engine. Total capacity - 21 gpm.

**POWER DISTRIBUTION** - Outriggers, outrigger extension cylinders, mast lift cylinders, main ram cylinder, mast locking cylinders - 3000 psi.

**FILTER** - Return line type. Full flow with bypass protection, replaceable cartridges.

**RESERVOIR** - 420 U.S. gallons.

**ELECTRICAL** - 12 volt system.

**TIRES** - 10:00 x 15 14 ply highway tread  
General PWR Jet Nygen.

**WHEELS** - Steel spoke 7½ in. x 15 in. 4" x 15" spacer.

**AXLES** - 94" track 20,000 lb. axle  
12½" x 7½" S cam air brakes.

**SUSPENSION** - Neway Air Ride Suspension 25,000 lbs. capacity.

**OVERALL LENGTH** - 65 feet.

**OVERALL WIDTH** - 10 feet.

**OVERALL HEIGHT** - 13 feet 5½ inches.

**HIGHWAY SPEED** - 50 M.P.H.

**ERECTION TIME** - 16 minutes (after outriggers are set).

**FIFTH WHEEL LOADING** - 44,000 lbs.

## ENGINE

### Upper Deck

Make and Model	Caterpillar 3208
Cylinders	8 cylinder
Displacement	636 cubic inches
Net HP	165 HP
Governed	2600 RPM
Electrical	24 volt
Fuel Capacity	150 U.S. gallons

### Lower - Undercarriage

Make and Model	Ford 192 diesel
Cylinders	4 cylinder
Displacement	192 cubic inches
Net HP	52 HP
Governed	2550 RPM
Electrical	12 volt
Fuel Capacity	60 U.S. gallons

## HOIST

**DESCRIPTION:** Series parallel circuitry and two motors provide either high line pull or high line speed. Power up and down, equal speed, planetary reduction with integral automatic brake.

**HOIST DATA** — Grove Model 30A-2S-17-D26

<b>Drum Dimensions</b>	16 inch diameter barrel
	26 inch length
	24 inch diameter flange

### Performance

HIGH SPEED RANGE	LOW SPEED RANGE
Single Line Speed - 450 FPM (maximum)	Single Line Speed - 225 FPM (maximum)
Single Line Pull - 7500 lbs. (maximum)	Single Line Pull - 15,000 lbs. (maximum)

**Drum Rope Capacity** — 760 feet of ¾ inch

**Permissible Single Line Rope Pull**

¾ inch 18 x 7 IWRC non-rotating - 15,000 lbs.

Specifications are subject to change without notice.

## DIMENSIONS

Crane in travel position.

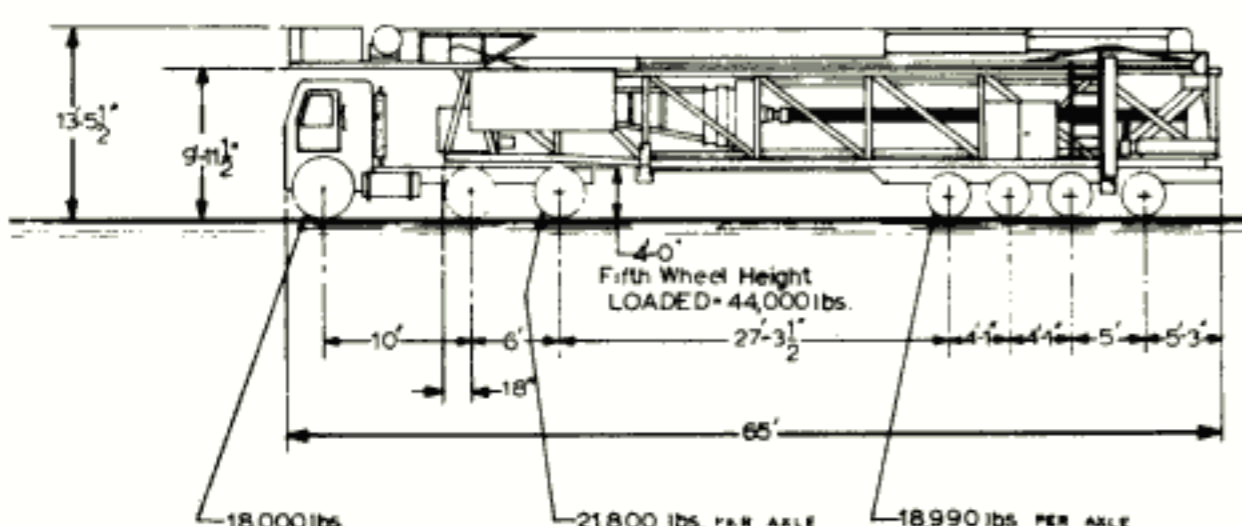

Crane with outriggers in position.  
(Boom and mast in travel position).

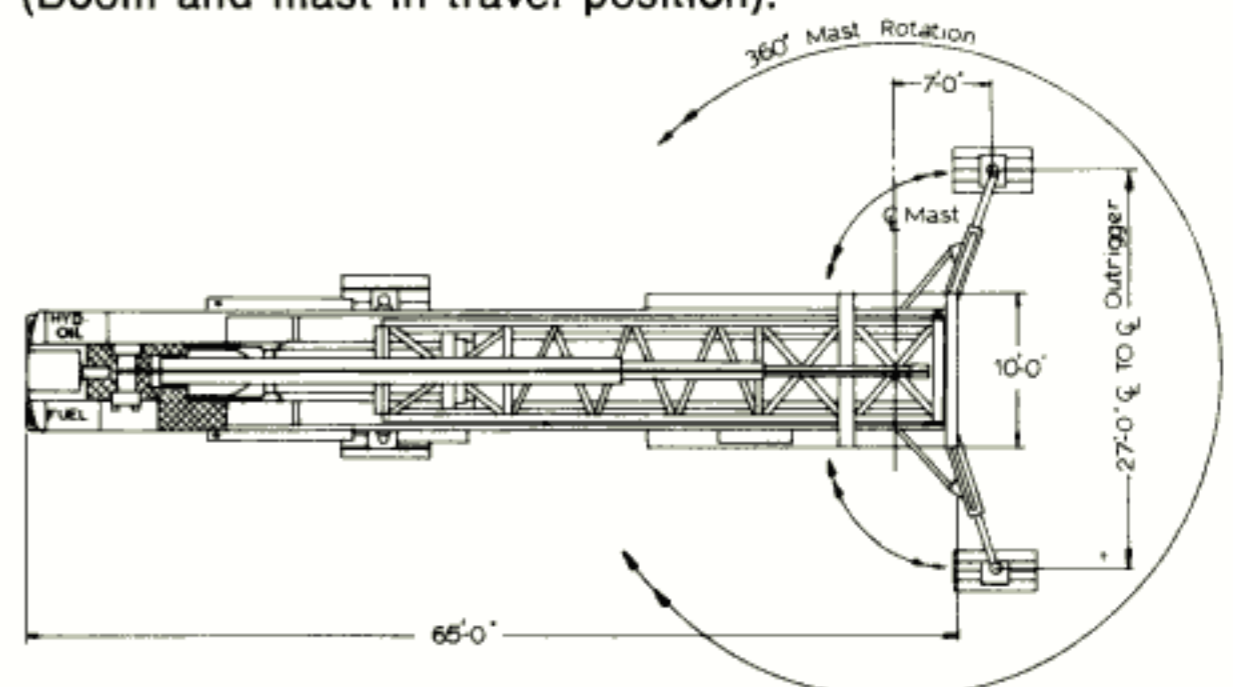





**HOIST**

Grove 2 speed hoist permits a high line speed of 450 f.p.m. with maximum single line pull of 7500 lbs. Low line speed of 225 f.p.m. with maximum single line pull of 15000 lbs.



**ANTI-TWO BLOCK DEVICE**

A safety feature to ensure that no damage occurs to cable, blocks and sheaves by over-running line.



**OUTRIGGERS**

Light weight aluminium floats stored on crane. Grove outrigger jack cylinders with the exclusive Grove Spin-Locks to give faster and safer set up.



**DUAL CONTROL SYSTEM**

Crane may be operated from 3 positions: from the cab at top of mast, from the ground, or from the building.

**LOAD MOMENT SYSTEM**

An overload protection device. When operation approaches 90% of rated capacity, a warning buzzer and light notifies the operator. If lifts are attempted beyond 100% of capacity, all crane functions which can overload the machine are cut out. The operator can still swing, lower hoist, retract or raise boom to reduce operating radius.

**SWING**

360° continuous on a ball bearing turntable. Swing at top of the mast. Minimal tail swing interference. Flat boom tip height 140'.

Crane locked in first operating position.

217' — Time elapsed: 16 minutes.







5400

**RATED LIFTING CAPACITIES IN POUNDS  
OUTRIGGERS FULLY EXTENDED  
LIFTING CAPACITIES - 360°**

Radius in Feet	Boom Length in Feet								
	32	38	44	50	56	62	68	74	80
10	60,000								
12	50,000	50,000	45,500	42,500	40,000				
15	41,000	41,000	31,000	31,000	31,000	28,000	26,000		
20	32,000	32,000	27,800	27,800	20,600	20,600	20,600	20,600	20,000
25	23,400	23,400	23,400	20,500	20,500	20,500	15,000	15,000	15,000
30		18,800	18,400	18,400	15,900	14,800	14,800	14,800	14,800
35			14,700	14,700	14,700	14,700	12,500	12,500	12,500
40			11,900	11,900	11,900	11,900	11,900	11,900	10,300
50					8,600	8,600	8,600	8,600	8,600
60							6,200	6,200	6,200
70								4,600	4,600
75									4,000

All capacities are based on structural strength and do not exceed 66 2/3% of the tipping load, in accordance with SAE J-765 and SAE J-987.

**JIB CAPACITIES IN POUNDS  
40 ft. JIB No Offset**

Boom Angle	Rated Load	Radius in Feet
75°	6,500	27
70°	4,500	36
65°	3,700	46
60°	3,100	56
55°	2,600	65
50°	2,400	73
45°	2,100	80
40°	1,900	88
35°	1,700	95
30°	1,600	99
26°	1,500	104
0°	1,300	115

**LINE PULL & REEVING INFORMATION**

HOIST — Grove 30A  
 CABLE SPECS. — 3/4 in. Trulay 18 x 7, IPS, IWRC  
 PERMISSIBLE LINE PULL — 15,000 lbs.  
 For multiple part reeving, use one line for each 15,000 lbs of load or portion thereof.

**WEIGHT REDUCTION FOR LOAD HANDLING DEVICES**

40 Ft. JIB with 32-80 Ft. BOOM — Erected ..... 1,000 lbs.  
 HOOK BLOCKS —  
 30 Ton, 2 Sheave ..... 600 lbs.  
 7 1/2 Ton, Headache Ball ..... 165 lbs.

NOTE: All load handling devices and boom attachments are considered part of the load and suitable allowances must be made for their combined weight.

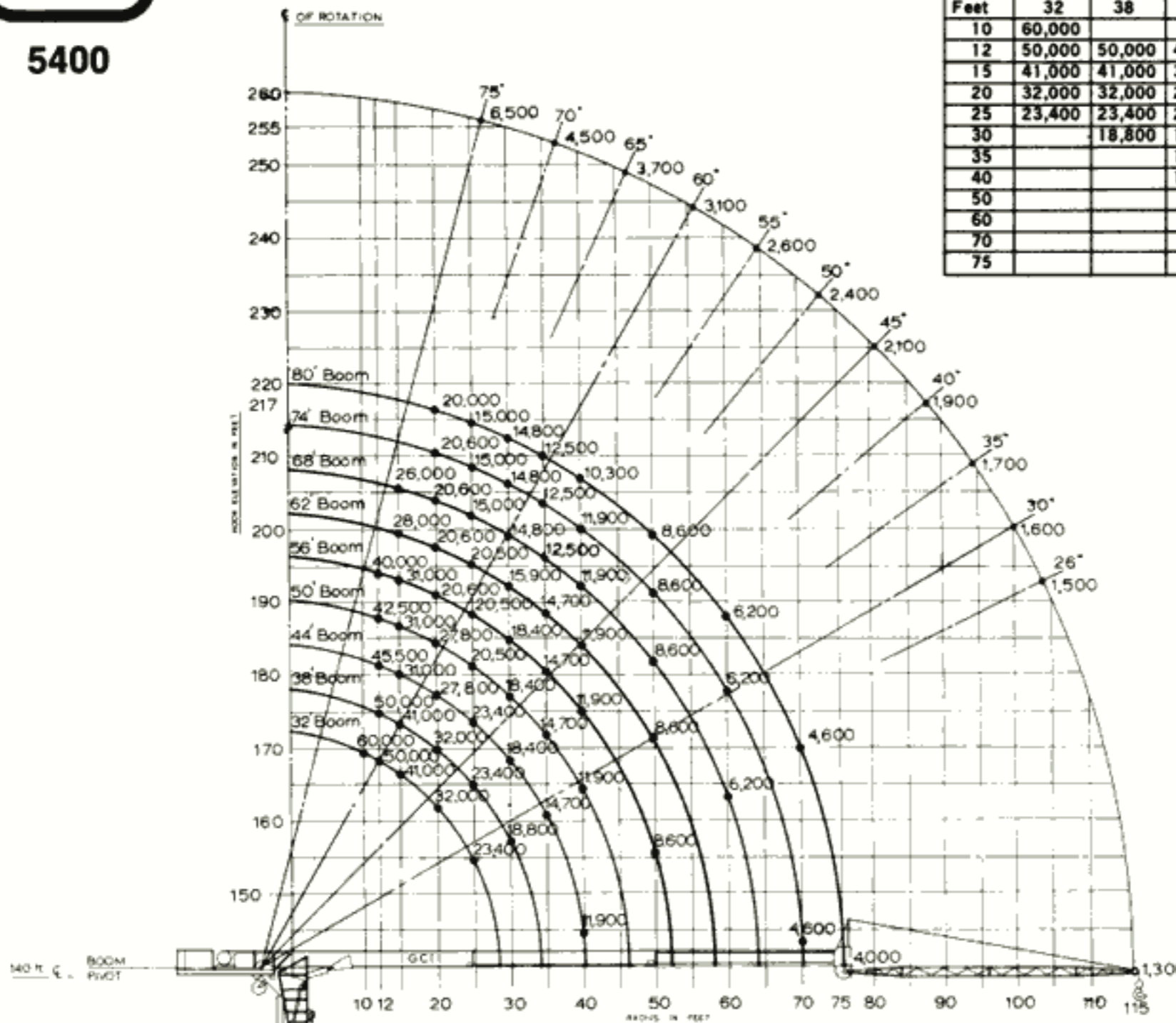

**NOTES TO LIFTING CAPACITIES**

- The Crane must not be operated and mast must be retracted in winds over 35 m.p.h.
- Rated lifting capacities are based on freely suspended loads. They are the maximum covered by the Manufacturer's Warranty with the machine leveled and standing on a firm supporting surface. Ratings are based on rear outriggers being extended to their maximum positions with safety screws turned down. Mast cylinder pressure must be maintained, with a minimum pressure of 1800 P.S.I., with the exception of first operating height.
- Practical working loads for each particular job shall be established by the user depending on operating conditions; including the supporting surface and other factors affecting stability, hazardous surroundings, experience of personnel, handling of loads, etc.
- Operating radius is the horizontal distance from the axis of rotation to the centerline of the hoist line or tackle with loads applied.
- The jib may be used for single line lifting crane service only.
- Operation is not intended nor approved for any conditions outside of the ones hereon.
- The power-telescoping boom sections are synchronized to extend each section equally. If the sections are not equally extended, extend or retract fully to resynchronize.
- The maximum load which may be telescoped is limited by hydraulic pressure, boom angle, boom lubrication, etc. It is safe to attempt to telescope any load within the limits of the rated lifting capacity chart.
- If actual boom length is between rated lengths shown, use lifting capacity for next longer rated length.
- For concrete bucket operation, weight of bucket and load must not exceed 90% of rated lifting capacities as indicated by warning light.
- Loads over 7500 lbs. must be handled only in low speed.
- Load block must be centered on boom for multiple reeving.
- Always lift load clear of ground with hoist as booming up is not protected against overloading.
- Load Moment Indicator and travel limit switches are to be used as an assistance to the operator and are not to be considered as a safety protection.



**General Crane Industries Ltd.**

670 INDUSTRIAL ROAD, LONDON, ONTARIO N5V 1V1  
 A Division of Grove Manufacturing Company