

■
 ○
 * V15.45

GRU A MONTAGGIO RAPIDO
GRUE A MONTAGE RAPIDE
GRUA DE RAPIDO MONTAJE
GRUA DE MONTAGEM RAPIDA
QUICK SELFERECTING CRANE
HYDRAULISCHER SCHNELLMONTAGEKRAN

DIN H1 - B3

Curve di carico – Courbes de charges – Load diagrams – LastKurven – Curvas de cargas

	<table border="1"> <tr><td>3</td><td>29</td><td>34</td><td>m</td></tr> <tr><td>800</td><td>800</td><td>800</td><td>kg</td></tr> </table>	3	29	34	m	800	800	800	kg	OP	<table border="1"> <tr><td>3</td><td>29</td><td>34</td><td>m</td></tr> <tr><td>1000</td><td>1000</td><td>1000</td><td>kg</td></tr> </table>	3	29	34	m	1000	1000	1000	kg												
3	29	34	m																												
800	800	800	kg																												
3	29	34	m																												
1000	1000	1000	kg																												
	<table border="1"> <tr><td>3</td><td>10.8</td><td>12</td><td>14</td><td>16</td><td>18</td><td>20</td><td>22</td><td>24</td><td>26</td><td>28</td><td>30</td><td>32</td><td>35</td><td>m</td></tr> <tr><td>4000</td><td>4000</td><td>3480</td><td>2880</td><td>2440</td><td>2110</td><td>1860</td><td>1650</td><td>1490</td><td>1350</td><td>1230</td><td>1130</td><td>1040</td><td>950</td><td>kg</td></tr> </table>	3	10.8	12	14	16	18	20	22	24	26	28	30	32	35	m	4000	4000	3480	2880	2440	2110	1860	1650	1490	1350	1230	1130	1040	950	kg
3	10.8	12	14	16	18	20	22	24	26	28	30	32	35	m																	
4000	4000	3480	2880	2440	2110	1860	1650	1490	1350	1230	1130	1040	950	kg																	
	<table border="1"> <tr><td>3</td><td>11.2</td><td>12</td><td>14</td><td>16</td><td>18</td><td>20</td><td>22</td><td>24</td><td>26</td><td>28</td><td>30</td><td>m</td></tr> <tr><td>4000</td><td>4000</td><td>3670</td><td>3030</td><td>2570</td><td>2230</td><td>1960</td><td>1750</td><td>1570</td><td>1420</td><td>1300</td><td>1200</td><td>kg</td></tr> </table>	3	11.2	12	14	16	18	20	22	24	26	28	30	m	4000	4000	3670	3030	2570	2230	1960	1750	1570	1420	1300	1200	kg				
3	11.2	12	14	16	18	20	22	24	26	28	30	m																			
4000	4000	3670	3030	2570	2230	1960	1750	1570	1420	1300	1200	kg																			
	<table border="1"> <tr><td>3</td><td>19.3</td><td>20</td><td>22</td><td>24</td><td>26</td><td>28</td><td>30</td><td>32</td><td>35</td><td>m</td></tr> <tr><td>2000</td><td>2000</td><td>1910</td><td>1700</td><td>1540</td><td>1400</td><td>1280</td><td>1180</td><td>1090</td><td>1000</td><td>kg</td></tr> </table>	3	19.3	20	22	24	26	28	30	32	35	m	2000	2000	1910	1700	1540	1400	1280	1180	1090	1000	kg								
3	19.3	20	22	24	26	28	30	32	35	m																					
2000	2000	1910	1700	1540	1400	1280	1180	1090	1000	kg																					
	<table border="1"> <tr><td>3</td><td>20.2</td><td>22</td><td>24</td><td>26</td><td>28</td><td>30</td><td>m</td></tr> <tr><td>2000</td><td>2000</td><td>1800</td><td>1650</td><td>1480</td><td>1350</td><td>1250</td><td>kg</td></tr> </table>	3	20.2	22	24	26	28	30	m	2000	2000	1800	1650	1480	1350	1250	kg														
3	20.2	22	24	26	28	30	m																								
2000	2000	1800	1650	1480	1350	1250	kg																								
	<table border="1"> <tr><td>3</td><td>16</td><td>18</td><td>20</td><td>22</td><td>24</td><td>26</td><td>28</td><td>30</td><td>32</td><td>35</td><td>m</td></tr> <tr><td>2500</td><td>2500</td><td>2110</td><td>1910</td><td>1700</td><td>1540</td><td>1400</td><td>1280</td><td>1180</td><td>1090</td><td>1000</td><td>kg</td></tr> </table>	3	16	18	20	22	24	26	28	30	32	35	m	2500	2500	2110	1910	1700	1540	1400	1280	1180	1090	1000	kg						
3	16	18	20	22	24	26	28	30	32	35	m																				
2500	2500	2110	1910	1700	1540	1400	1280	1180	1090	1000	kg																				
	<table border="1"> <tr><td>3</td><td>16</td><td>18</td><td>20</td><td>22</td><td>24</td><td>26</td><td>28</td><td>30</td><td>m</td></tr> <tr><td>2500</td><td>2500</td><td>2230</td><td>2000</td><td>1800</td><td>1650</td><td>1480</td><td>1350</td><td>1250</td><td>kg</td></tr> </table>	3	16	18	20	22	24	26	28	30	m	2500	2500	2230	2000	1800	1650	1480	1350	1250	kg										
3	16	18	20	22	24	26	28	30	m																						
2500	2500	2230	2000	1800	1650	1480	1350	1250	kg																						
	<table border="1"> <tr><td>3</td><td>11.2</td><td>14</td><td>m</td></tr> <tr><td>4000</td><td>4000</td><td>3000</td><td>kg</td></tr> </table>	3	11.2	14	m	4000	4000	3000	kg		<table border="1"> <tr><td>3</td><td>14</td><td>m</td></tr> <tr><td>2000</td><td>2000</td><td>kg</td></tr> </table>	3	14	m	2000	2000	kg														
3	11.2	14	m																												
4000	4000	3000	kg																												
3	14	m																													
2000	2000	kg																													

Reazioni – Reactions – Réactions – Eckdrücke – Reacciones – Reacções

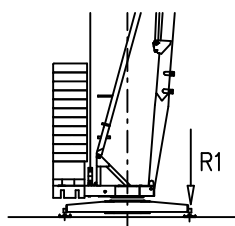

R1 ● 25 t ■ 17.5 t
 ▲ 15 t ○ 26.52 t

- | | | |
|-------------------------------|---------------------------------------|--------------------------------------|
| ● Reazioni in servizio | ● Reactions in service | ● Réactions en service |
| ■ Reazioni fuori servizio | ■ Reactions out of service | ■ Réactions hors service |
| ▲ Peso della gru senza assali | ▲ Dead weight without transport axles | ▲ Poids de construction sans essieux |
| ○ Peso zavorra rotante | ○ Ballast weight | ○ Poids du lest |
-
- | | | |
|--------------------------------------------|------------------------------------------|-------------------------------------------|
| ● Reaktionskräfte in betrieb | ● Reacciones en servicio | ● Em serviço |
| ■ Reaktionskräfte außer betrieb | ■ Reacciones fuera de servicio | ■ Fora de serviço |
| ▲ Konstruktionsgewicht ohne transportachse | ▲ Peso de la grua sin tren de transporte | ▲ Peso de la grua sem carro de transporte |
| ○ Ballastgewicht | ○ Peso de lastre | ○ Peso de lastre rotativo |

Montaggio – Montage – Erection – Montage – Montaje – Montagem

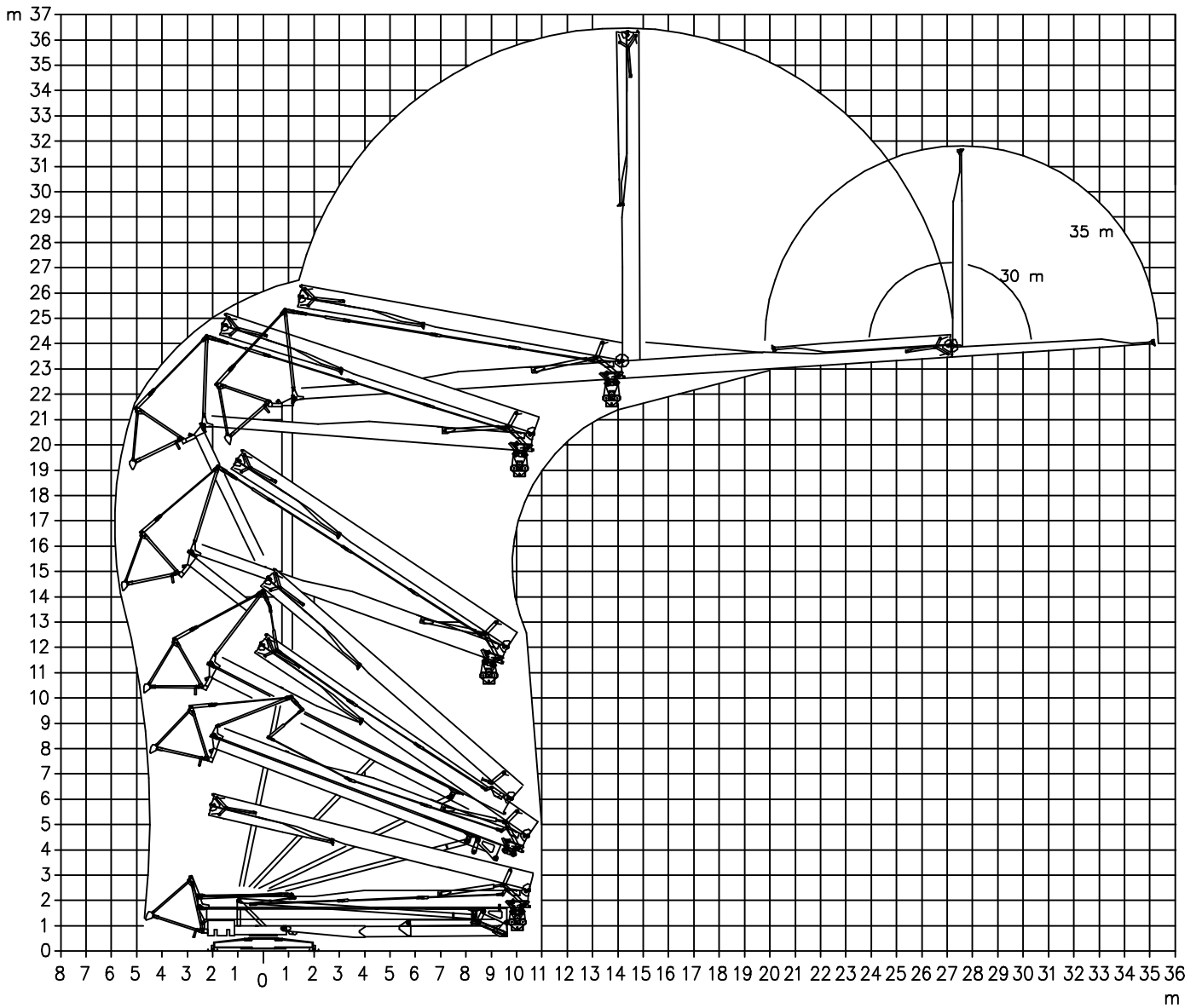



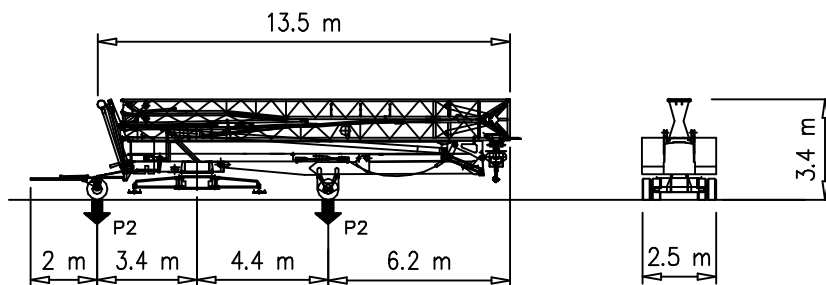



Trasporto – Transport – Transport – Transport – Transporte



P1	kg	9800
P2	kg	12380
Ptot	kg	22180

Meccanismi – Mechanisms – Mécanismes – Antriebe – Mecanismos

Sollevamento V12.40 Hoisting Levage Heben Elevaciòn Elevaçao	▲ ● ▼		1a	4 m/min	2000 kg	10 kW
			2a	20 m/min	2000 kg	
			3a	40 m/min	1000 kg	
			1a	2 m/min	4000 kg	
			2a	10 m/min	4000 kg	
			3a	20 m/min	2000 kg	
Sollevamento V15.45 Hoisting Levage Heben Elevaciòn Elevaçao			1a	4 m/min	2500 kg	11 kW
			2a	15 m/min	2500 kg	
			3a	25 m/min	2000 kg	
			4a	45 m/min	1000 kg	
Carrello Trolleying Distribution Katzfahren Distribuciòn Distribuiçao			1a	5 m/min	4000 kg	2.2 kW
			2a	17 m/min	4000 kg	
			3a	34 m/min	2000 kg	
Carrello Trolleying Distribution Katzfahren Distribuciòn Distribuiçao	◀■▶		1a	5 m/min	800 kg	2.2 kW
			2a	17 m/min	800 kg	
Carrello Trolleying Distribution Katzfahren Distribuciòn Distribuiçao			1a	5 m/min	1000 kg	3 kW
			2a	17 m/min	1000 kg	
Rotazione Slewing Orientation Schwenken Orientaciòn Rotaçao			1a	0 → 0.2	giri/min tr/min rp/min	2.2 kW
			2a	0 → 0.5		
			3a	0 → 0.8		

Rete elettrica – Réseau – Mains supply – Netzstrom – Red – Rede electrica	400V – 50 Hz
---------------------------------------------------------------------------	--------------

Potenza elettrica necessaria – Puissance électrique nécessaire Necessary electric power – Anschlusswert – Potencia electrica necesaria	V12.40 18 kVA V15.45 20 kVA
-------------------------------------------------------------------------------------------------------------------------------------------	--------------------------------

 FMgru s.r.l. via Emilia 11–29010 Pontenure PC ITALY tel. 0523/510446 ric.aut. fax 0523/510365 www.fmgru.com e-mail: info@fmgru.com	DIN 15018 2000/14/CE	
---------------------------------------------------------------------------------------------------------------------------------------------------------------------------------------------------------------------------------	-------------------------	--



Documento commerciale non contrattuale
Per tutte le informazioni tecniche riferirsi
alle corrispondenti istruzioni

Unverbindliches Vertriebsdokument.
Für technische Informationen, siehe die
entsprechenden Anweisungen.

This commercial document is not legally
binding. For any technical information, please
refer to the corresponding instructions.

Documento comercial no contractual
Para cualquier información técnica,
ver la noticia correspondiente.

Code: 15ICA37B80A0			
Ed.	Data	Rev	Data
1	05.06.03	1	13.12.05