

M440D TOWER CRANE

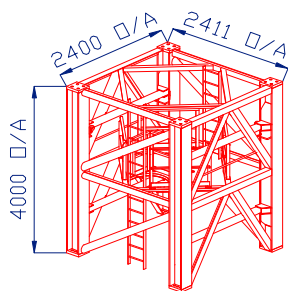

TOWER TYPE
392

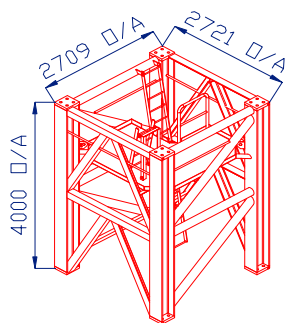

TOWER TYPE
442

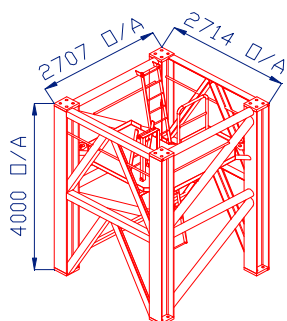

TOWER TYPE
441

TYPICAL LOADS	
LOAD (T)	RADIUS (m)
50	12.5
25	22.5
2.7	65
13.1	40

Technical Data Sheet

FAVELLE
FAVCO

M440D RADIUS AND CAPACITY



Boom Length (m)	Max Rad. for Max WLL (m)	Min Rad. (m)	WLL at Min Rad. (T)	1 FALL																			Max Rad. (m)	WLL at Max Rad. (T)	
				Radius (metres) & Capacity (tonnes)																					
				7.5	10.0	15.0	20.0	25.0	30.0	32.5	35.0	37.5	40.0	42.5	45.0	47.5	50.0	52.5	55.0	57.5	60.0	62.5			65.0
68.8	12.5	5.8	25.0	25.0	25.0	22.5	19.5	17.2	15.0	13.7	12.6	11.3	10.2	9.2	8.3	7.6	6.9	6.1	5.5	4.9	4.3	3.6	2.7	67.5	1.9
64.2	15.0	5.5	25.0	25.0	25.0	23.0	20.0	16.9	15.2	13.6	12.4	11.2	10.2	9.3	8.4	7.6	6.9	6.3	5.7	4.8	4.0	-	-	63.0	3.9
59.6	20.0	5.2	25.0	25.0	25.0	25.0	21.7	17.5	15.8	14.2	12.9	11.8	10.7	9.7	8.8	8.0	7.3	6.6	6.0	-	-	-	-	58.6	5.6
55.0	22.5	4.9	25.0	25.0	25.0	25.0	22.8	18.1	16.3	14.6	13.2	12.0	11.0	10.0	9.3	8.5	8.0	-	-	-	-	-	-	54.1	7.7
50.4	22.5	4.5	25.0	25.0	25.0	25.0	23.0	18.3	16.6	14.9	13.6	12.4	11.4	10.4	9.5	-	-	-	-	-	-	-	-	49.7	8.7
45.8	22.5	4.2	25.0	25.0	25.0	25.0	23.5	18.7	17.0	15.4	14.1	12.8	11.7	10.6	-	-	-	-	-	-	-	-	-	45.3	10.5
41.2	22.5	3.9	25.0	25.0	25.0	25.0	23.8	19.0	17.3	15.6	14.2	13.1	-	-	-	-	-	-	-	-	-	-	-	40.8	12.7
36.6	22.5	3.6	25.0	25.0	25.0	25.0	24.0	19.4	17.7	16.1	-	-	-	-	-	-	-	-	-	-	-	-	-	36.4	15.2
32.0	22.5	3.3	25.0	25.0	25.0	25.0	24.2	19.5	-	-	-	-	-	-	-	-	-	-	-	-	-	-	-	31.9	17.7

Boom Length (m)	Max Rad. for Max WLL (m)	Min Rad. (m)	WLL at Min Rad. (T)	2 FALL																			Max Rad. (m)	WLL at Max Rad. (T)	
				Radius (metres) & Capacity (tonnes)																					
				7.5	10.0	15.0	20.0	25.0	30.0	32.5	35.0	37.5	40.0	42.5	45.0	47.5	50.0	52.5	55.0	57.5	60.0	62.5			65.0
68.8	-	5.9	25.0	25.0	25.0	22.5	19.5	17.2	15.0	13.7	12.6	11.3	10.2	9.2	8.3	7.6	6.9	6.1	5.5	4.9	4.3	3.6	2.7	67.3	1.9
64.2	-	5.6	32.0	32.0	30.6	26.3	23.0	20.0	16.9	15.2	13.6	12.4	11.2	10.2	9.3	8.4	7.6	6.9	6.3	5.7	4.8	4.0	-	62.9	3.9
59.6	-	5.3	32.0	32.0	32.0	29.8	25.8	21.7	17.5	15.8	14.2	12.9	11.8	10.7	9.7	8.8	8.0	7.3	6.6	6.0	-	-	-	58.4	5.6
55.0	-	4.9	44.0	44.0	44.0	41.0	29.8	22.8	18.1	16.3	14.6	13.2	12.0	11.0	10.0	9.3	8.5	8.0	-	-	-	-	-	54.0	7.7
50.4	12.0	4.6	50.0	50.0	50.0	42.0	30.2	23.0	18.3	16.6	14.9	13.6	12.4	11.4	10.4	9.5	-	-	-	-	-	-	-	49.5	8.7
45.8	13.0	4.3	50.0	50.0	50.0	42.3	30.6	23.5	18.7	17.0	15.4	14.1	12.8	11.7	10.6	-	-	-	-	-	-	-	-	45.1	10.5
41.2	13.2	4.0	50.0	50.0	50.0	42.8	30.7	23.8	19.0	17.3	15.6	14.2	13.1	-	-	-	-	-	-	-	-	-	-	40.7	12.7
36.6	13.3	3.6	50.0	50.0	50.0	43.3	30.8	24.0	19.4	17.7	16.1	-	-	-	-	-	-	-	-	-	-	-	-	36.2	15.2
32.0	13.3	3.3	50.0	50.0	50.0	43.5	31.3	24.2	19.5	-	-	-	-	-	-	-	-	-	-	-	-	-	-	31.8	17.7

LOAD CHARTS

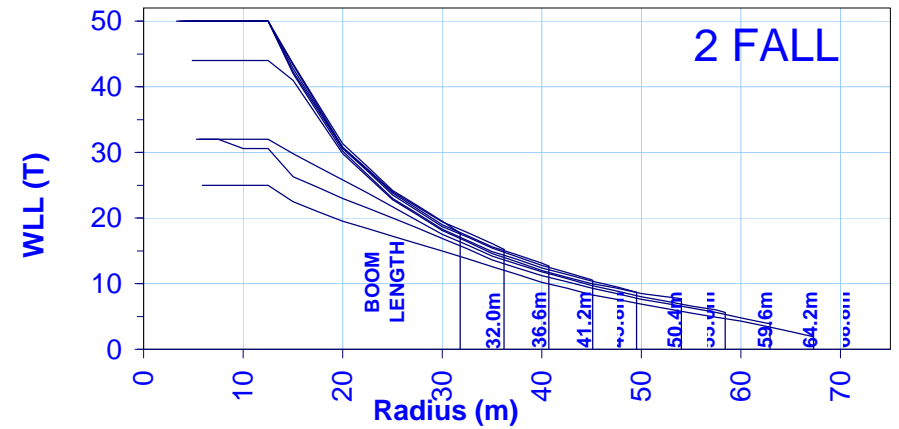
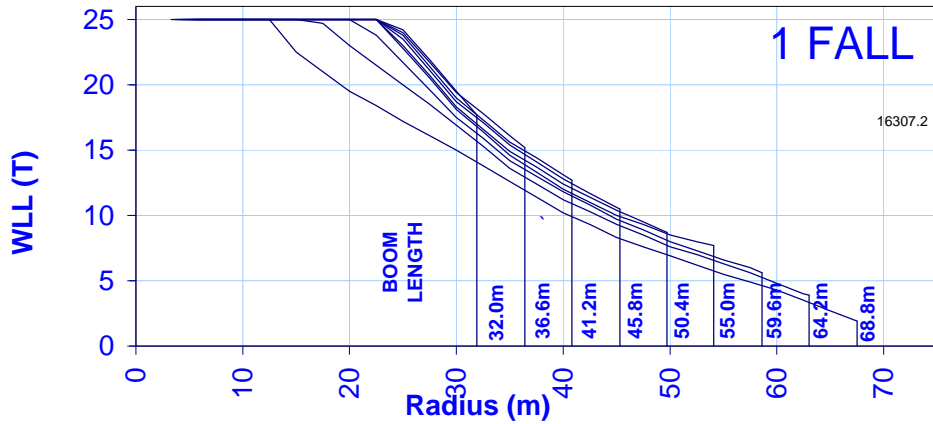

HOIST SPEEDS

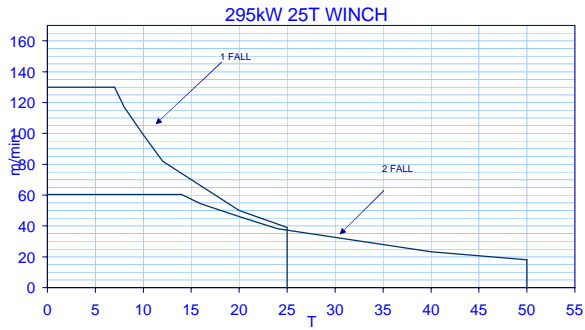

1 FALL	
TONNE	SPEED (m/s)
7	130
8	117
10	99
12	82
20	50
25	39

2 FALLS	
TONNE	SPEED (m/s)
14	60
16	54
20	46
24	38
40	23
50	18

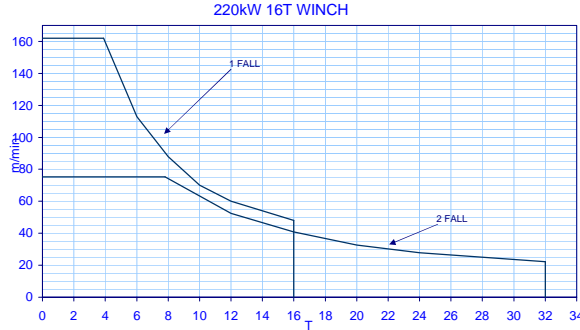

1 FALL	
TONNE	SPEED (m/s)
3.9	162
6	113
8	88
10	70
12	60
16	48

2 FALLS	
TONNE	SPEED (m/s)
7.8	75
12	53
16	41
20	33
24	28
32	22

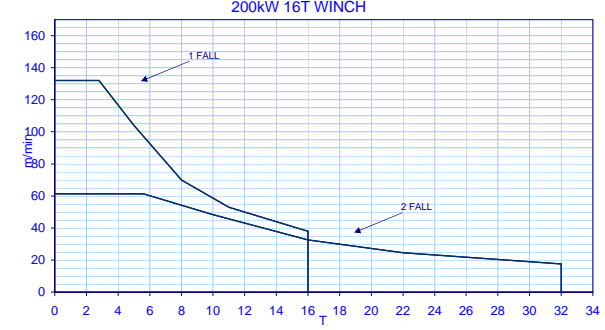

1 FALL	
TONNE	SPEED (m/s)
2.8	132
5	104
8	70
11	53
16	38

2 FALLS	
TONNE	SPEED (m/s)
5.6	61
10	48
16	33
22	25
32	18

LUFF AND SLEW SPEEDS

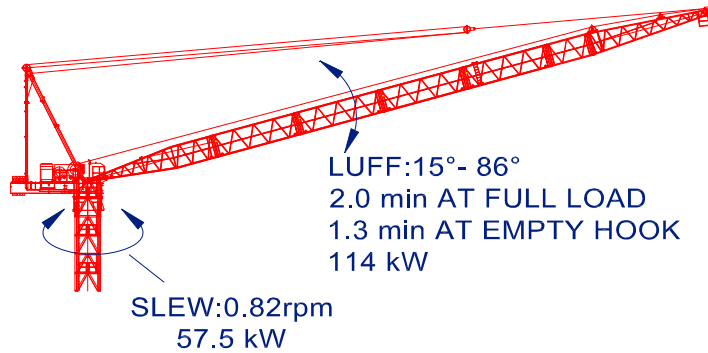

CRANE FREE-STANDING WITHOUT EXTERNAL CLIMBER

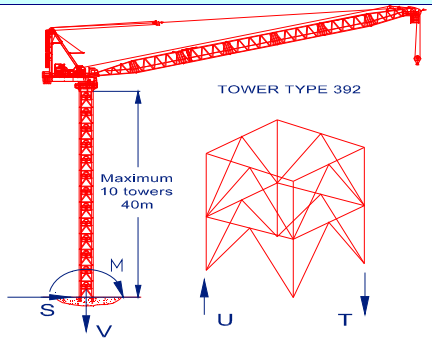

CRANE FREE-STANDING WITH EXTERNAL CLIMBER

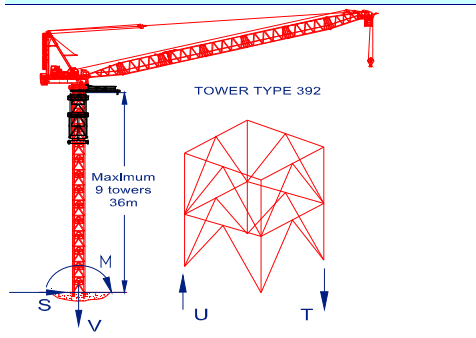

WITH CLIMBER- ONE TIE ABOVE THE BASE

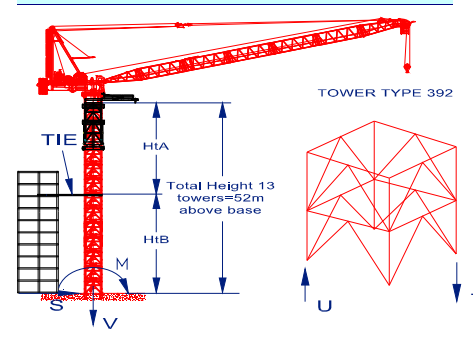

INTERNAL CLIMBER ON COLLARS

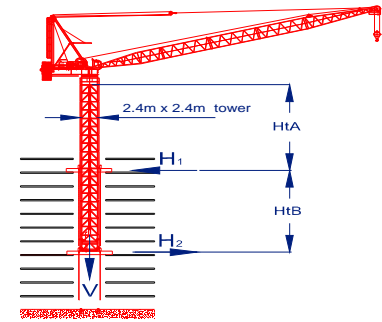

BUILDING REACTION

Design Load	I/S*	O/S†	Unit
NO. of Towers	10	10	-
M	847	854	mT
V	203	160	T
S	7	28	T
T	337	329	T
U	236	249	T
Ht _{Total}	40	40	m

BUILDING REACTION

Design Load	I/S*	O/S†	Unit
NO. of Towers	9	9	-
M	842	859	mT
V	213	170	T
S	7	31	T
T	338	333	T
U	232	248	T
Ht _{Total}	36	36	m

BUILDING REACTION

Design Load	I/S*	O/S†	Unit
NO. of Towers	13	13	-
TIE	63	79	T
M	403	342	mT
V	234	191	T
S	54	43	T
T	195	163	T
U	78	68	T
Ht _A	30	30	m
Ht _B	22	22	m
Ht _{Total}	52	52	m

BUILDING REACTION

Design Load	I/S*	O/S†	Unit
NO. of Towers	10	10	-
V	202	158	t
H ₁	91	101	t
H ₂	83	69	t
Ht _A	30	30	m
Ht _B	9.6	9.6	m

16307.2

*:IN SERVICE WIND=20 m/s

†:OUT OF SERVICE WIND= 42 m/s

Notes:

- Structure is designed using permissible stress method. These loads will vary by change of boom length, height and type of tower, actual site wind conditions, no of falls and change of wind speed.
- To calculate alternative options for M440D refer to Favelle Favco Design Sheet named "Crane Weight Wind Chart"

M440D GENERAL DIMENSIONS WITH 441 TYPE TOWERS (TYPICAL CASES AT 55.0m BOOM LENGTH)

CRANE FREE-STANDING WITHOUT EXTERNAL CLIMBER

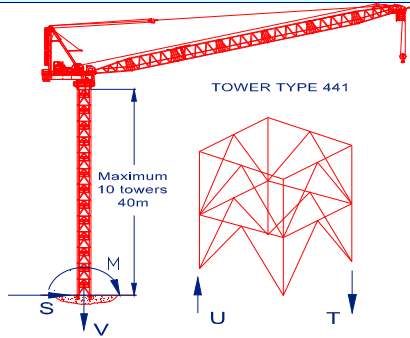

BUILDING REACTION			
Design Load	I/S*	O/S†	Unit
NO. of Towers	10	10	-
M	842	857	mT
V	196	153	T
S	7	28	T
T	297	291	T
U	199	214	T
Ht _{Total}	40	40	m

CRANE FREE-STANDING WITH EXTERNAL CLIMBER

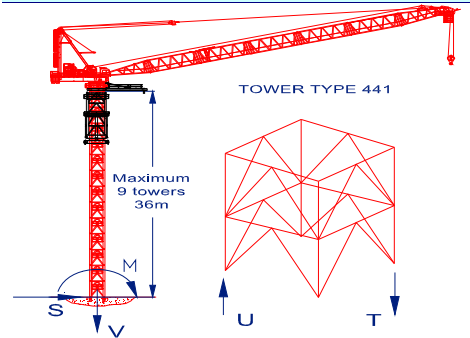

BUILDING REACTION			
Design Load	I/S*	O/S†	Unit
NO. of Towers	9	9	-
M	827	808	mT
V	206	162	T
S	7	30	T
T	295	278	T
U	192	198	T
Ht _{Total}	36	36	m

WITH CLIMBER- ONE TIE ABOVE THE BASE

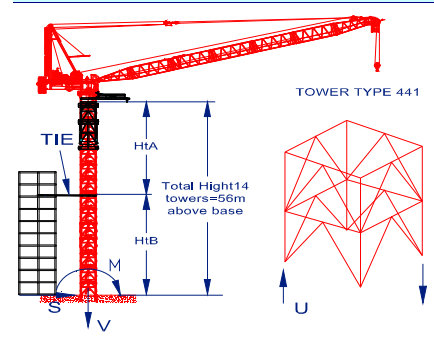

BUILDING REACTION			
Design Load	I/S*	O/S†	Unit
NO. of Towers	14	14	-
TIE	65	89	T
M	420	405	mT
V	229	186	T
S	56	52	T
T	181	166	T
U	67	73	T
Ht _A	34	34	m
Ht _B	22	22	m
Ht _{Total}	56	56	m

INTERNAL CLIMBER ON COLLARS

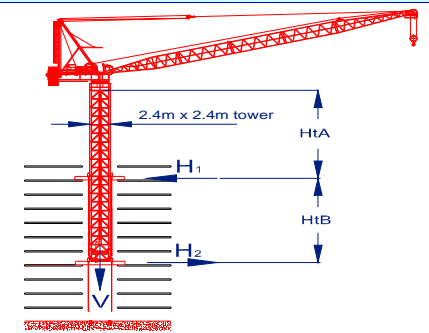

BUILDING REACTION			
Design Load	I/S*	O/S†	Unit
NO. of Towers	10	10	-
V	196	153	t
H ₁	90	101	t
H ₂	82	69	t
Ht _A	30	30	m
Ht _B	9.6	9.6	m

*:IN SERVICE WIND=20 m/s

†:OUT OF SERVICE WIND= 42 m/s

Notes:

1. Structure is designed using permissible stress method. These loads will vary by change of boom length, height and type of tower, actual site wind conditions, no of falls and change of wind speed.
2. To calculate alternative options for M440D refer to Favelle Favco Design Sheet named 'Crane Weight Wind Chart'

M440D GENERAL DIMENSIONS WITH 442 TYPE TOWERS (TYPICAL CASES AT 55.0m BOOM LENGTH)

CRANE FREE-STANDING WITHOUT EXTERNAL CLIMBER

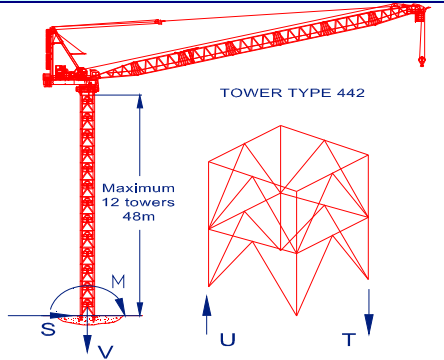

CRANE FREE-STANDING WITH EXTERNAL CLIMBER

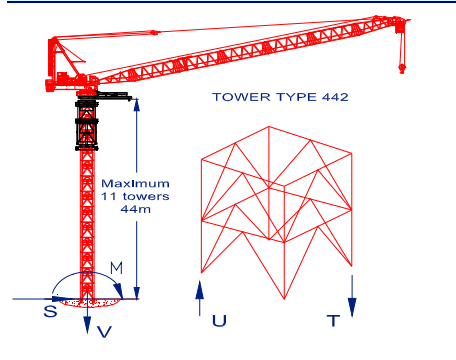

WITH CLIMBER- ONE TIE ABOVE THE BASE

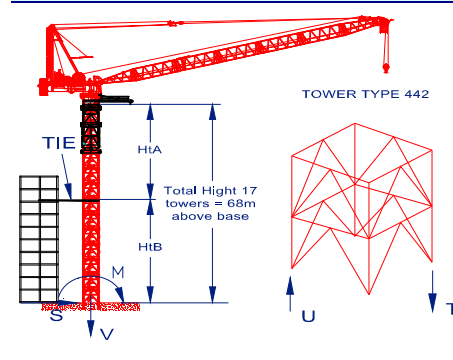

INTERNAL CLIMBER ON COLLARS

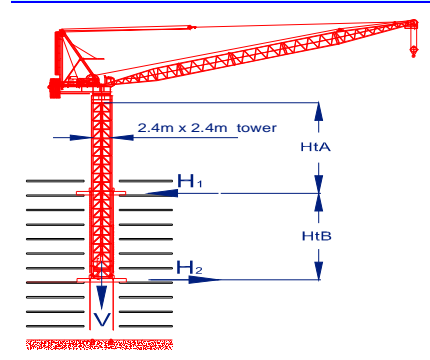

BUILDING REACTION

Design Load	I/S*	O/S†	Unit
NO. of Towers	12	12	-
M	915	1108	mT
V	209	166	T
S	7	31	T
T	322	368	T
U	217	285	T
Ht _{Total}	48	48	m

BUILDING REACTION

Design Load	I/S*	O/S†	Unit
NO. of Towers	11	11	-
M	915	1136	mT
V	219	176	T
S	8	34	T
T	325	379	T
U	215	291	T
Ht _{Total}	44	44	m

BUILDING REACTION

Design Load	I/S*	O/S†	Unit
NO. of Towers	17	17	-
TIE	53	84	T
M	440	472	mT
V	249	206	T
S	43	42	T
T	192	191	T
U	67	88	T
Ht _A	38	38	m
Ht _B	30	30	m
Ht _{Total}	68	68	m

BUILDING REACTION

Design Load	I/S*	O/S†	Unit
NO. of Towers	12	12	-
V	209	166	t
H ₁	98	131	t
H ₂	90	96	t
Ht _A	38	38	m
Ht _B	9.6	10	m

*:IN SERVICE WIND=20 m/s

†:OUT OF SERVICE WIND= 42 m/s

Notes:

1. Structure is designed using permissible stress method. These loads will vary by change of boom length, height and type of tower, actual site wind conditions, no of falls and change of wind speed.
2. To calculate alternative options for M440D refer to Favalle Favco Design Sheet named 'Crane Weight Wind Chart'

MACHINERY DECK ASSEMBLY

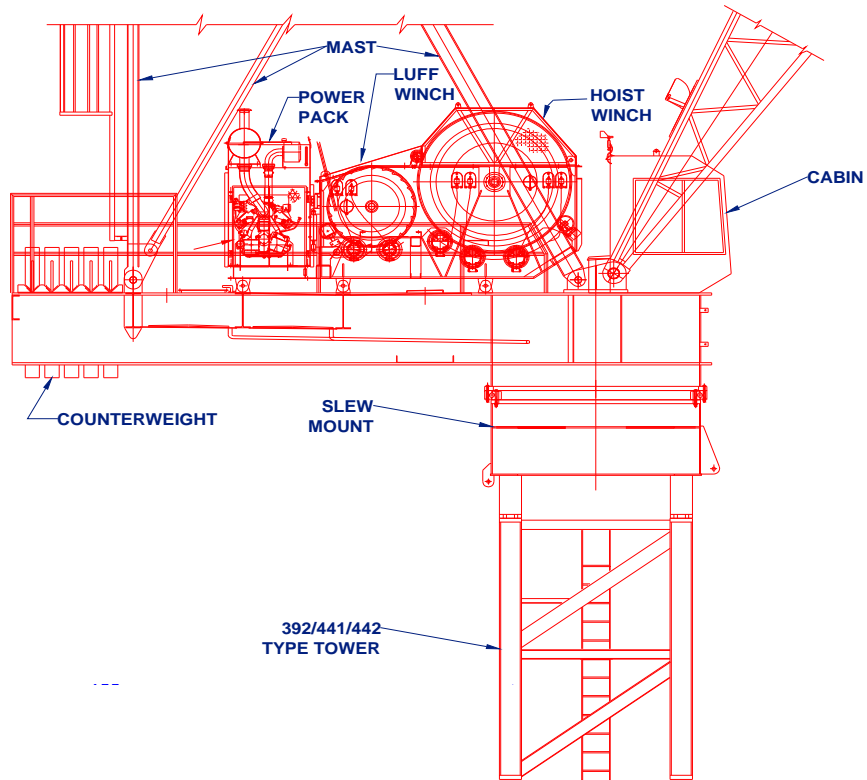

EXTERNAL CLIMBING
INSTALLATION CLEARANCE

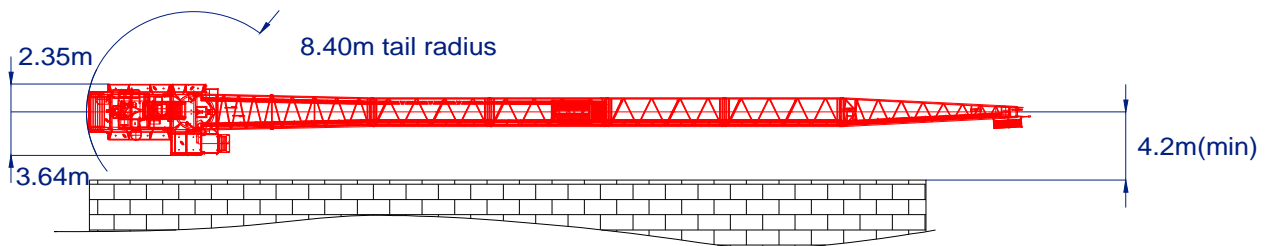

OUT OF SERVICE CONFIGURATION

Boom Length (m)	RECCOMENDED OUT OF SERVICE PARKED RADIUS	
	Radius (m)	Angle (°)
68.8	19	74
64.2	20	72
59.6	22	69
55.0	23	66
50.4	25	61
45.8	24	53
41.2	21	60
36.6	18	61
32.0	15	62

*:MAX OUT OF SERVICE WIND SPEED = 42 m/s

ITEM	QTY	DESCRIPTION		LENGTH L (mm)	HEIGHT H (mm)	WIDTH W (mm)	WEIGHT PER ITEM (kg)
1	1	SPLIT DECK-FRONT (INCL. SLEW DRIVE, PINS, PLATFORMS & HANDRAILS)		3590	1964	3430	7901
2	1	SPLIT DECK-REAR (INCL. PLATFORMS & HANDRAILS)		6625	1430	3340	8694
3	2	MAST FRONT LEG		12850	483	305	1267EA
	1	MAST HEAD		981	922	795	565
	2	MAST BACK LEG		11672	154	237	425EA
	1	BUFFER		3660	231	2859	381
		MAST ASSEMBLY (INC. SHEAVES, HEAD PIN, LADDERS, BUFFER AND PLATFORMS)					6553
4	1	CABIN & PLATFORM ASSEMBLY		4076	2308	1710	1448
5	1	25T POWER PACK HOIST AND LUFF ASSY (NO ROPE) (INCL 1125L OF OIL)		5709	3851	3130	15334 (16270)
6	1	25T DRUM (NO ROPE)		1560	2170		4937
7	1	16T POWER PACK HOIST AND LUFF ASSY (NO ROPE) (INCL 750L OF OIL)		5085	2704	2753	12920 (13544)
8	1	16T DRUM (NO ROPE)		1468	1710		3522
9	1	BOOM BOTTOM 13.7m (INC. WALKWAY&PINS)		13913	2416	3052	2493
10	1	BOOM TOP 13.7m (INC. DEFLECTOR, SHEAVES & PINS) (PENDANT & PLATFORM)		14319	3698	2416	2905
11	5	BOOM EXTENSION 9.2m (BRIDLE PLATFORM 203 kg)		9316	2624	2414	1398 (1665)
12	1	BRIDLE		1610	1061	1160	620
13	1	SLEW MOUNT (INCL. PLATFORMS 725Kg)		3419	1928	3310	6796
	1	SLEW RING (INCL. BOLTS)		3120 DIA.	232		2348
		Total					9511
14	1	EXTERNAL CLIMBER		14343	4435	4435	17680
15	1	MONORAIL		7430	1271	600	1839
16	10	COUNTER WEIGHT		3100	2070	1227	4160
17	1	HOOK - 2/1 FALL (50/25T)		2505	505	1242	1102
18	1	TOWER SECTION 392 (INC.LADDER,HAND RAIL,PLATFORM)		2400	4000	2411	5136
19	1	TOWER SECTION 441 (INC.LADDER,HAND RAIL,PLATFORM)		2707	4000	2714	4680
20	1	TOWER SECTION 442 (INC.LADDER,HAND RAIL,PLATFORM)		2709	4000	2721	5152
21	1	HOIST ROPE 25T (36mm) @ 6.5kg/m		600m			4056
22	1	HOIST ROPE 16T (32mm) @ 5.01kg/m		600m			3126
23	1	LUFF ROPE (32mm) @ 4.9kg/m		150m			764
24	1	PENDANT ROPE (44mm) @ 9.4kg/m		104m			1017