

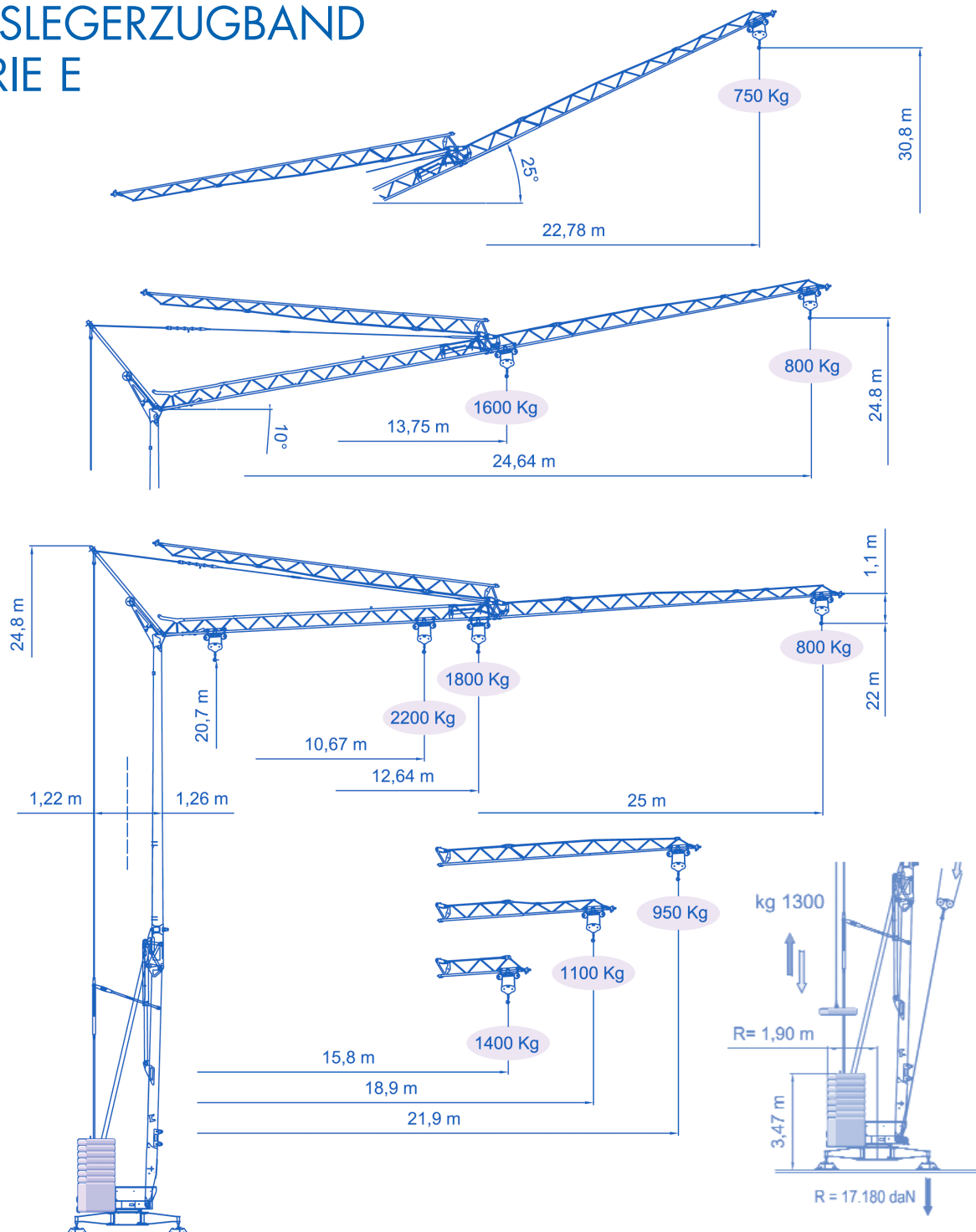

### UNTENDREHER AUSLEGERZUGBAND SERIE E



|  |       |      |      |      |      |     |     |     |
|--|-------|------|------|------|------|-----|-----|-----|
|  Kg | 2200  | 1738 | 1468 | 1266 | 1110 | 986 | 884 | 800 |
|  m  | 10,67 | 13   | 15   | 17   | 19   | 21  | 23  | 25  |

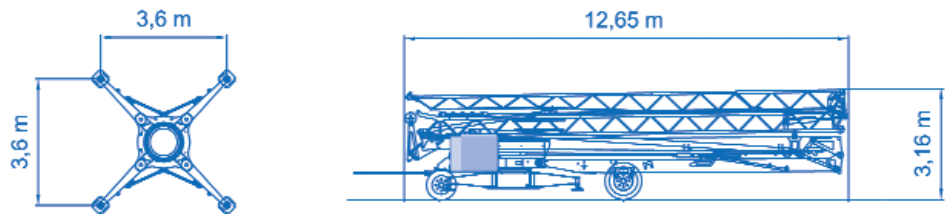
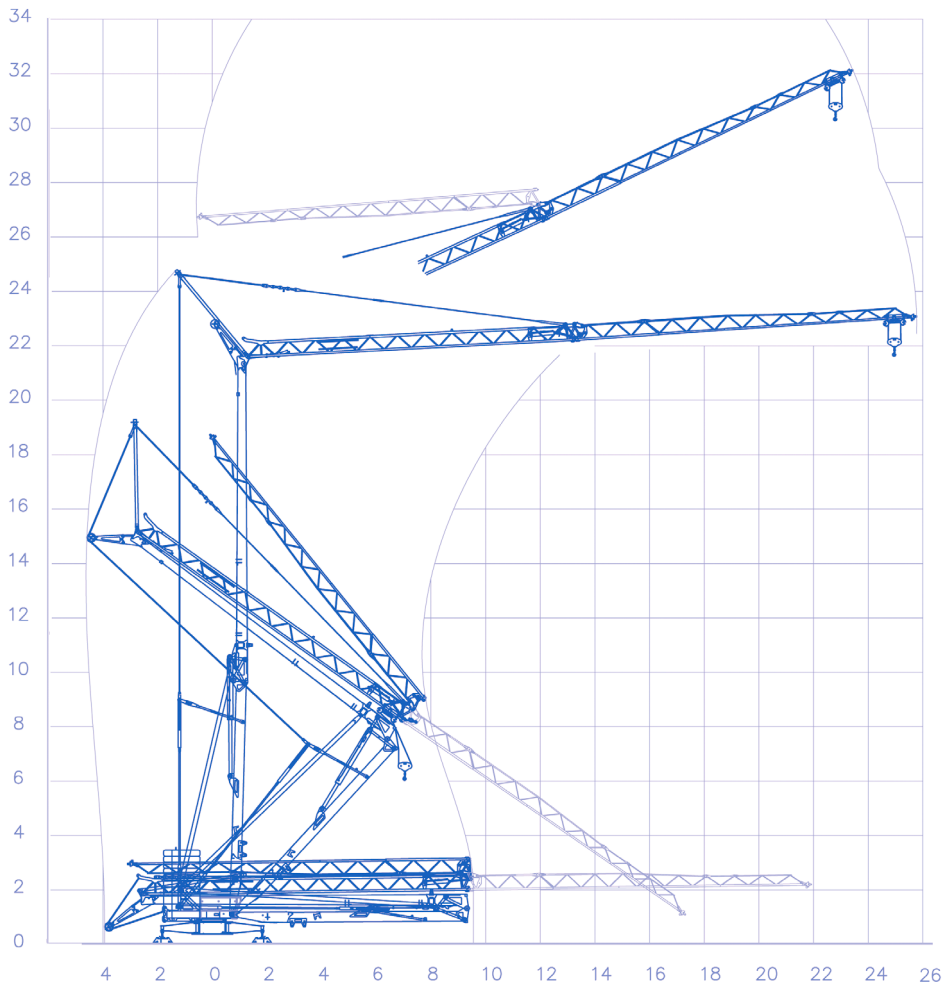

|  |             |      |     |              |
|--|-------------|------|-----|--------------|
|  | m/min       | kg   | kw  | MONOFASE     |
|  | 5           | 2200 | 3   | MONOFASICA   |
|  | 15          | 2200 | 4,5 | MONOPHASEC   |
|  | 22          | 1000 | 8   | ONE-PHASE    |
|  | 42          | 850  |     | WECHSELSTROM |
|  | m/min       |      | kw  | v            |
|  | 0 - 1       |      | 1,5 | 230          |
|  | m/min       |      | kw  | MAX. POWER   |
|  | 17,6        |      | 3   | KVA 6        |
|  | 28,6        |      |     |              |
|  | 39,3 / 53,5 |      |     |              |

# EUROGRU®

Am Dornbusch 10, 64390 Erzhausen

Telefon +49 6150 13440

Fax +49 6150 7002