

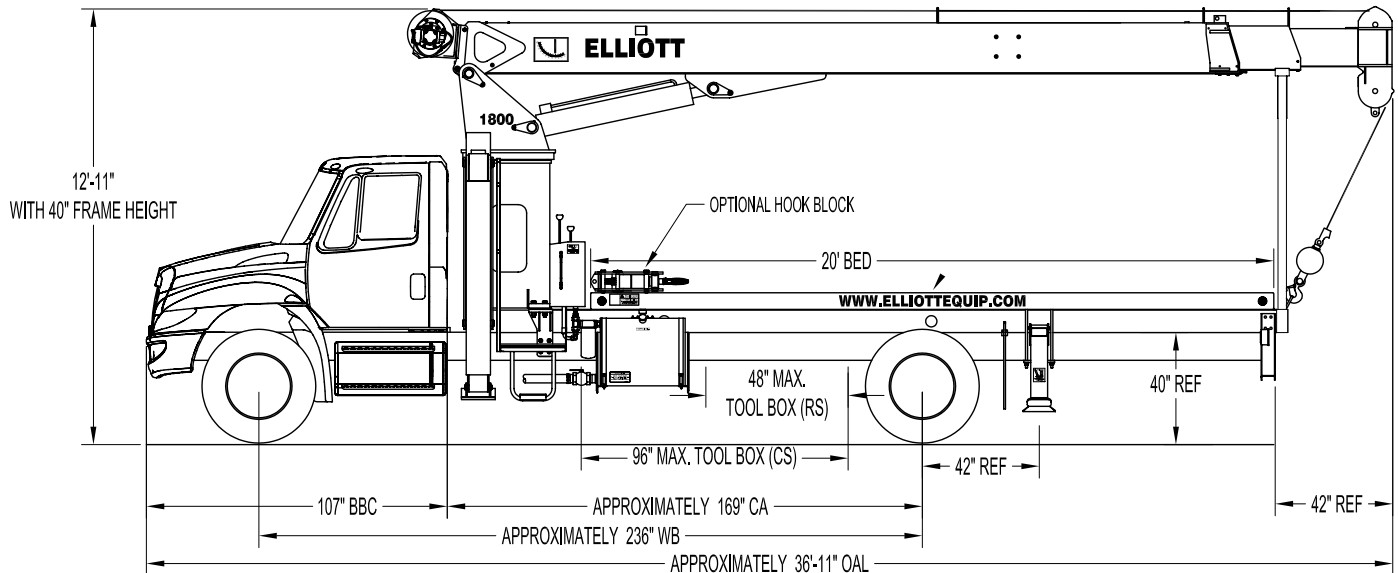

1860F SIDE VIEW DIAGRAM



- | | | | |
|---------------------------------|-------------------------------------|---------------------------------|-----------------------|
| • Maximum Vertical Reach | 90'/27,4 m | • Powered Boom Sections | 3 |
| • Working Area | 180 Degrees Standard (360 Optional) | • Overall Height | 12'11"/3,9 m |
| • Lifting Capacity | 36,000 lbs/16 329 kg | • Operator Controls | Dual Operator Standup |
| • Boom Length | 60'/18,3 m | • Outrigger Type Front | A-Frame |
| • Crane Weight (Dry) | 14,845 lbs/6734 kg | • Outrigger Spread Front | 20'10"/6,3 m |
| • Jib Lengths | 20'/6,1 m | • Outrigger Type Rear | A-Underslung |
| • Winch Bare Drum Pull | 12,800 lbs/5806 kg | • Outrigger Spread Rear | 10'4"/3,1 m |

TECHNICAL SPECIFICATIONS

Crane Capacity: 36,000 lbs at five feet load radius.

Maximum Tip Height: 70' height (90' with optional 20' jib)

Control Console: Dual operator standup control stations equipped with four single axis control levers for the main crane controls. Operator station includes LMI display, bubble level gauge, engine start/stop switch, signal horn button, variable speed foot throttle, lifting capacity chart, range diagram chart, boom angle indicator, system pressure gauge, 12V DC power source, and cup holder. Outrigger lever controls at control consoles.

Boom: Three-section fully proportional, high strength steel plated rectangular tube sections. A maximum boom tip height of 70' mounted on a truck. The boom nose contains one floating upper sheave and two lower sheaves. Assembly includes heavy-duty cylinder fittings, pivot pins, and replaceable wear pads.

Winch: Mounted at the base of the boom for a long fleet angle and flat level spooling of cable. Winch is driven by a planetary reducer and powered by a hydraulic motor. Burst-of-speed winch provides increased line speed. The winch brake is spring applied, pressure release design. Supplied with 275' of 9/16" wire rope with a single line pull of 9,600 pounds, and a downhaul ball with swivel hook for single part line.

Load Moment Indicator System:

System senses hoist cylinder pressures, boom length and boom angle with hydraulic function lockout. The display console is equipped with a bar graph showing crane utilization, boom angle or boom length, a mode select controls for main boom and jib operation, and an anti-two block with an audio/visual warning and shut-off functions to limit hook-boom point contact.

Outriggers: One set of "A" Frame main outriggers with 20'10" span, and

one set of underslung "A" auxiliary outriggers with a 10'4" span.

Frame: Full length, all welded rigid 4-plate design sub-frame. Sub-frame allows for bolt-on addition of 18' bed.

Turret: Reverse offset turret is one-piece weldment. Turret rotates on large diameter ball bearing.

Rotation: Hydraulic motor drives turret through double reduction planetary swing drive for 372-degree non-continuous rotation. The swing drive system has a spring applied, pressure release brake.

Lift: One double-acting long stroke cylinder provides smooth and stable boom elevation. Holding valve prevents boom from falling in event of hose failure.

Boom Extension: Incorporates a single-stage hydraulic extension cylinder, attached to the largest boom section, with a proportional cable extension system driving the outermost section.

Hoses: All high pressure hoses are wire braid reinforced with a minimum safety factor of 4 to 1.

Cylinders: All cylinders use microhoned cylinder tubing, chrome shafts, top grade packing and protective rod wipers. Cylinder-mounted holding valves provided on all load-holding cylinders.

Hydraulic System: Equipped with cable-shift PTO, three-section gear pump, SAE O-ring face seals on pressure lines, and a 10-micron return line filter. The control valve distributes all flow to hoist system, swing circuit, and other crane functions. System is open center type.

Oil Tank Capacity: 70 gallon mounted to truck frame on roadside.

Cab Equipment: PTO cable with indicator lights installed in truck cab. U/L approved 5:BC dry chemical fire extinguisher installed in truck cab.

Operators Manual & Video: Two CD copies and one hard copy of operation, maintenance, safety and parts manual provided with each unit. Operational and safety video provided at delivery.

Installation: Unit installed on chassis, painted, system and tank filled with oil, tested, inspected, and ready to operate.

Standard Paint: Paint turret and boom white, outriggers red, and bed and boxes black.

Bumper: Bureau of Motor Carrier Safety rear bumper.

Weight: Approximately 14,845 lbs. with 18' steel-floor bed less truck.

Truck Chassis Required: Approx. 168" C.A. RBM 1,463,000 in-lb. per rail, 13,000 lb. front axle and 33,000 lb. GVWR required. Trucks must have front frame extension, 12V electrical system with high capacity alternator, cab clearance stop/tail/backup lights, and I.D. lamps. Recommended GVWR is minimum for BOOMTRUCK with flatbed only. Contact factory when additional equipment is to be added.

Options:

20' Fixed Jib.

Radio Remote Controls.

Superlink Short Jack Outriggers.

Gravity Leveled Steel Basket.

Front Jack for 360 Degree Area of Operation.

Hydraulic Tool Circuits on Bed.

Much more...

Elliott Equipment Company reserves the right to change the specification of any unit at any time without prior notice. This brochure is only a statement of general specifications on the date of this publication. For more detailed info on specific Elliott trucks go to www.elliottequip.com

MAXIMUM LIFTING CAPABILITIES

MAIN BOOM LOAD RATINGS WITH FULLY EXTENDED OUTRIGGERS

MAIN BOOM LOAD RATINGS											JIB LOAD RATINGS		
LOAD RATINGS IN LBS. WITH OUTRIGGERS AND STABILIZERS EXTENDED													
LOAD RADIUS (feet)	LOADED BOOM ANGLE	24 ft	LOADED BOOM ANGLE	A 33 ft	LOADED BOOM ANGLE	B 42 ft	LOADED BOOM ANGLE	C 51 ft	LOADED BOOM ANGLE	D 60 ft	LOAD RADIUS (feet)	LOADED BOOM ANGLE	JIB 20 ft
5	76	36,000									15	78	4,700
10	63	21,400	71	17,800	75	17,100	78	15,900			20	74	3,700
15	48	15,300	61	12,900	68	12,400	73	11,700	75	11,500	25	70.5	3,000
20	27	11,600	51	10,200	61	9,700	67	9,200	70	8,900	30	66.5	2,400
25			39	8,400	53	8,000	60	7,500	65	7,300	35	62.5	2,100
30			21	6,650	43	6,700	53	6,400	60	6,100	40	58.5	1,700
35					32	5,550	46	5,450	54	5,300	45	54	1,400
40					13	4,150	37	4,650	48	4,600	50	49.5	1,300
45							26	3,800	41	3,550	55	45	1,200
50									32	3,100	60	39.5	1,000
55									27	2,650	65	33.5	800
	0	7,200	0	4,700	0	3,300	0	2,400	0	1,800			
		350		250		200		150		150	DEDUCTIONS FOR STOWED FIXED LENGTH JIB		





NOTICE

- DO NOT DEADHEAD LINE BLOCK AGAINST BOOM TIP WHEN EXTENDING BOOM

- KEEP AT LEAST 5 WRAPS OF LOADLINE ON THE WINCH DRUM AT ALL TIMES

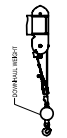
- USE ONLY 9/16" DIAMETER WIRE ROPE, AS SPECIFIED BELOW, WITH THE PROPER BREAKING STRENGTHS LISTED

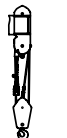
- ANTI-TWO-BLOCK SYSTEM MUST BE IN GOOD OPERATING CONDITION BEFORE OPERATING CRANE. SEE OPERATION & SAFETY MANUAL

1-PART LINE	2-PART LINE	3-PART LINE	4-PART LINE	ELLIOTT EQUIPMENT CO. SUPPLIED LOADLINE EQUIPMENT DEDUCTIONS:
				DOWNHAUL WEIGHT180 lbs ONE SHEAVE BLOCK.....375 lbs TWO SHEAVE BLOCK.....640 lbs
MAX PULL: 9,600 lbs	19,200 lbs	28,800 lbs	36,000 lbs	9/16" - 6 x 37 IWRC (3.5:1 S.F.) 33,600-lbs. BREAKING STRENGTH
MAX PULL: 9,060 lbs	18,120 lbs	27,180 lbs	36,000 lbs	9/16" - SPIN RESISTANT (5:1 S.F.) 45,300-lbs. BREAKING STRENGTH
MAX PULL: 7,680 lbs	15,360 lbs	23,040 lbs	30,720 lbs	9/16" - SPIN RESISTANT (5:1 S.F.) 38,400-lbs. BREAKING STRENGTH



Elliott Equipment Company
4427 South 76th Circle
Omaha, NE 68127
Phone: 402-592-4500
Fax: 402-592-4553
Email: sales@elliottequip.com

Built for You.
www.elliottequip.com

MAXIMUM RANGE CAPABILITIES

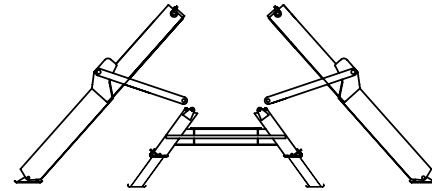

OUTRIGGERS AT FULL EXTENSION

RANGE DIAGRAM

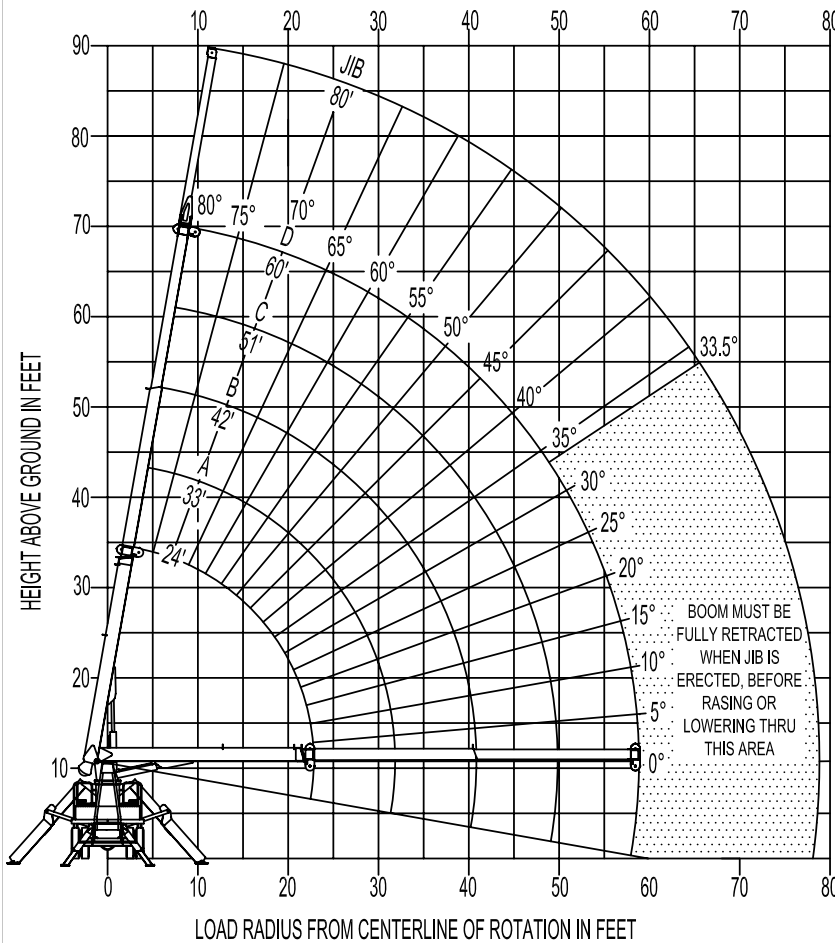

NOTE:

1. Operate jib by radius when main boom is full extended. Increase boom angle if necessary to maintain load radius.
2. When boom is retracted, operate jib by boom angles. Do not exceed any rated jib capacities at reduced boom lengths.
3. Capacities do not exceed 85% stability.
4. Load ratings above bold line are structurally limited.
5. Personnel handling is allowed only with full span outriggers.
6. Boom load ratings are based on loaded boom radius. Loaded boom angles are given as reference only.

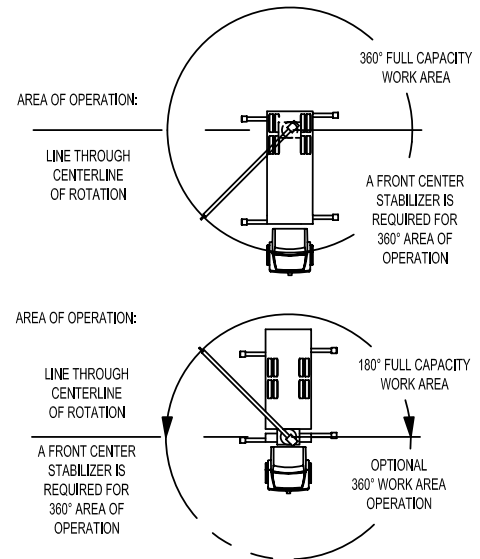

CHASSIS SPECIFICATIONS

	1860F BoomTruck
Wheelbase (WB)	236" / 599 cm
Cab to Axle (CA)	168" / 427 cm
Cab to End of Frame (EOF)	271" / 688 cm
Frame Section Modulus	13.3 in3-110,000 psi / 758,428 kPa
Front Axle Gross Weight Rating	13,000 lb / 5896 kg
Rear Axle Gross Weight Rating	20,000 lb / 9072 kg
Integral Front Frame Rails	Required for Front Stabilizer

Chassis data is minimum general requirements-not for engineering.
 Actual dimensions and truck data will depend on truck selection and axle configuration.
 *Minimum chassis weight is required to meet 85% stability requirements.

OPTIONS



Radio Remote Control

Interference protected radio remotes let you get closer to your work and have full control over your machine.

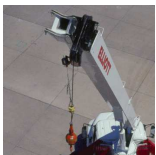

Pin-On Jib Attachment

One piece fixed jib that stows on the side of the boom and pins on the boom tip for easy placement while on the worksite.



Continuous Boom Rotation

Add the convenience of 360 degree area of operation by adding a special boom rotation bearing for swinging without stops.



Superlink Short Jack Outriggers

Reduce your outrigger spread with Elliott's patented Superlink outriggers that allow straight down outrigger deployment on one side and full crane operation on the other.



Tool Boxes

Optional tool boxes and bed storage can accommodate any storage need for tools, work materials and more.



Hook Block for Multi-Part Line

Elliott can install a 2-3 part hook block or a 4 part-hook block to improve lifting capabilities. The block can be stored at the rear of the bed.



Gravity Levelled Basket

Elliott's pin-on work platform pins onto the boom for easy installation and removal. Gravity leveling and mechanical rotation makes it a great accessory for any worksite.



Body Mounted Hose Reels and Circuits

Let us work with you to customize your tool compatibility by adding hose reels or hydraulic circuits to the crane bed.