

EFFER

RAISE THE VALUE



685



685

The 685 crane is the ultimate evolution of the medium – large truck cranes mountable on 26 ton trucks. A careful design optimisation of all components makes it possible to get excellent lifting performances, together with an extremely low weight. The introduction of the PROGRESS electronic control system has also made it possible to reach these results.

La gru 685 rappresenta la massima evoluzione delle gru medie grandi per autocarri anche da 26 ton. Una progettazione attenta all'ottimizzazione di tutti i componenti ha permesso di ottenere eccellenti prestazioni di sollevamento, unitamente ad un peso estremamente basso. I risultati ottenuti sono frutto anche dell'introduzione del sistema di controllo elettronico PROGRESS.

Kran 685 stellt die maximale Evolution im Segment der mittel-großen Ladekrane für Fahrzeuge bis 26 T zulässiges Gesamtgewicht dar. Eine sorgfältige Projektierung aller Komponenten hat es ermöglicht, ausgezeichnete Hubwerte zu erreichen, kombiniert mit einem sehr geringen Eigengewicht. Durch die Anwendung der PROGRESS Steuerung konnten diese Ergebnisse weiter optimiert werden.

La grue 685 est l'évolution technique ultime parmi les grues de grandes et moyennes dimensions équipant les camions jusqu'à 26T. L'optimisation et la conception minutieuse de tous les composants a permis d'obtenir des excellentes performances de levage et un poids extrêmement bas. Les résultats obtenus sont également le fruit de l'introduction du système de contrôle électronique PROGRESS.

La grúa 685 representa la máxima evolución de las grúas de la gama medio-pesada para camiones de hasta 26 t. Una proyección cuidadosa de todos los componentes ha permitido obtener excelentes prestaciones de elevación junto con un peso extremadamente bajo. Los resultados obtenidos son también fruto de la introducción del sistema de control electrónico PROGRESS.

5S

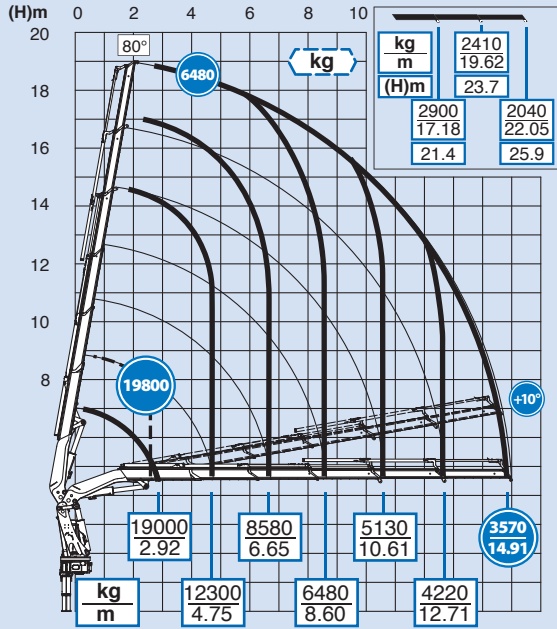

6S

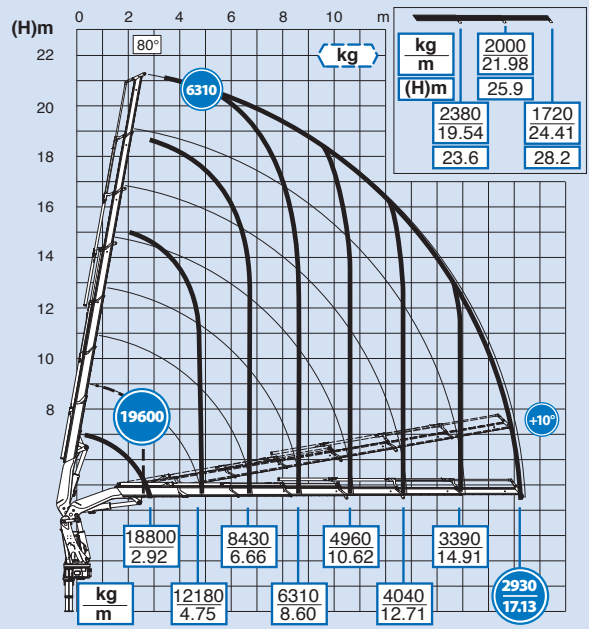

8S

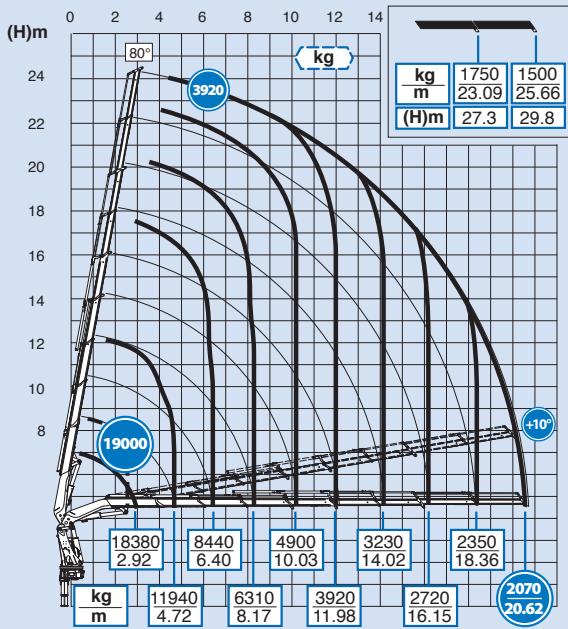

9S

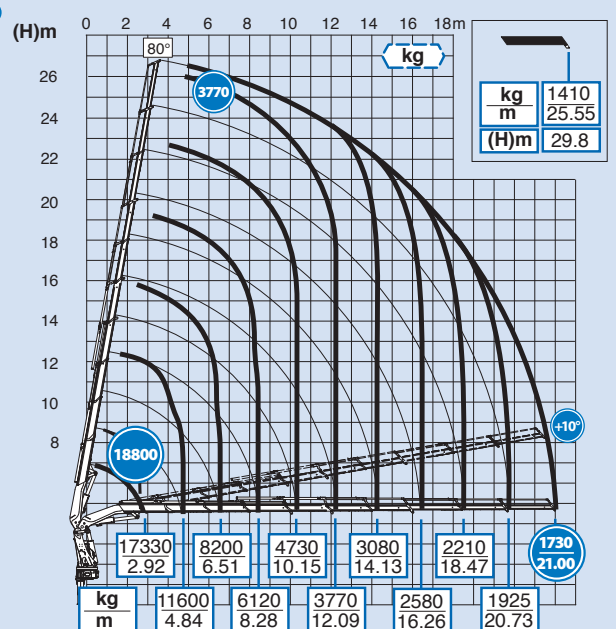

6S + JIB 6S light

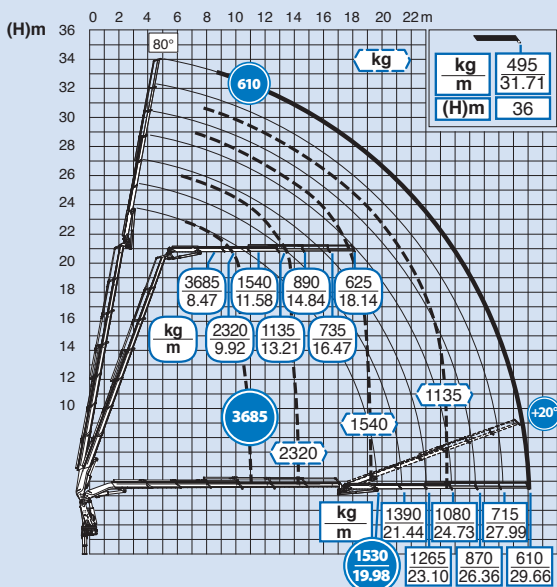

6S + JIB 4S heavy duty

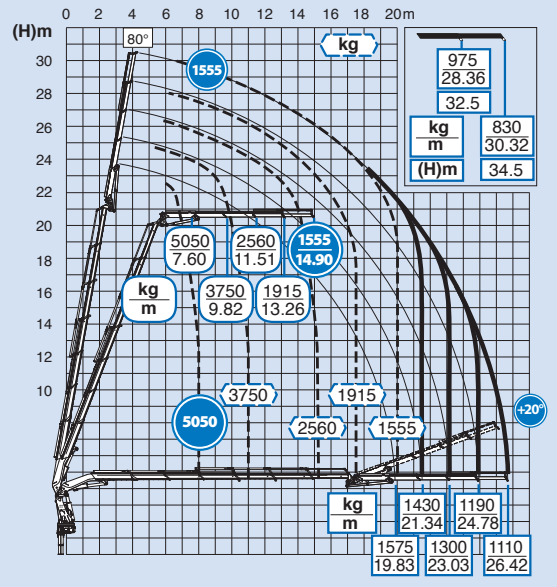

6S + JIB 6S heavy duty

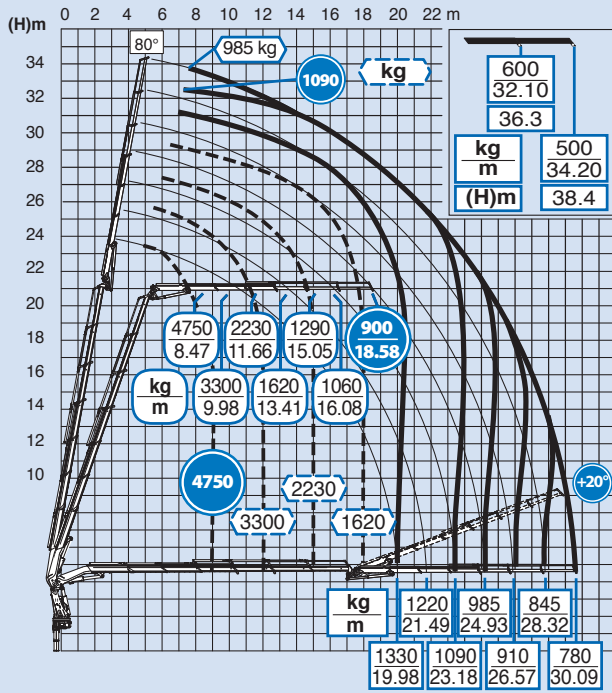

8S + JIB 4S

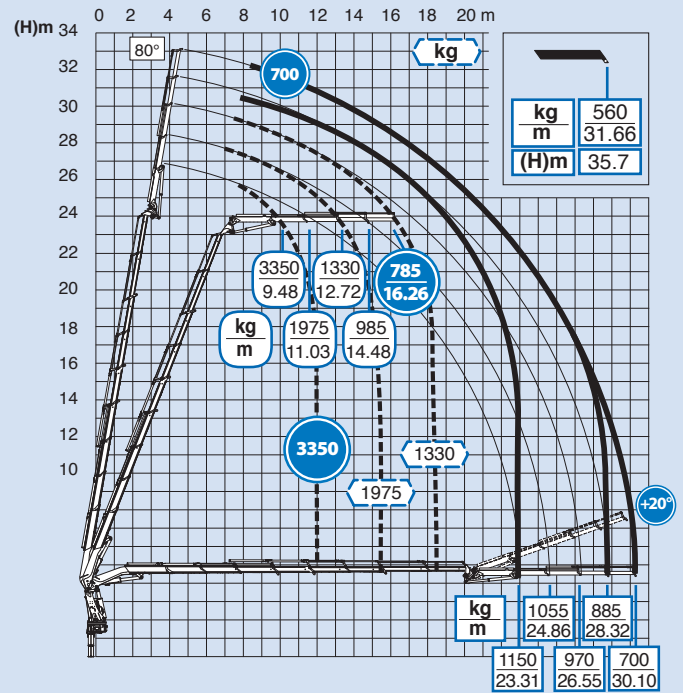

3S/4S/5S/6S/8S/9S

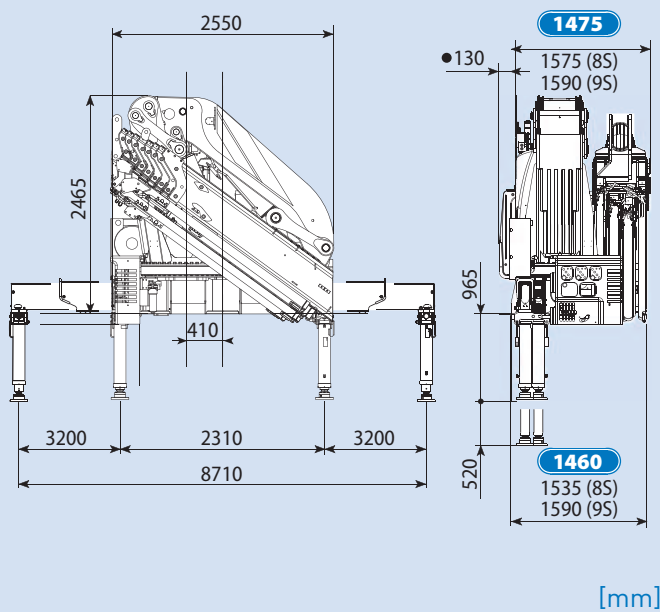

4S/5S/6S/8S + JIB

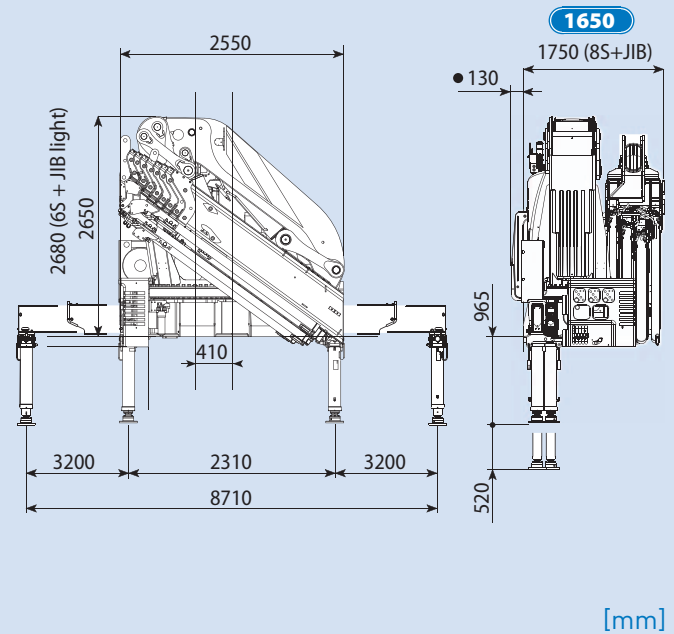

● Fitted tank size (optional, it fits within slewing dimensions) - Ingombro serbatoio installato (opzionale, rientra nell'ingombro di rotazione) - Abmessungen installierten Behälters (auf Wunsch, in dem Drehbereich enthalten) - Dimensions réservoir monté (optionnel, il est inclu dans l'encombrement de rotation) - Medidas exteriores máximas referidas al tanque instalado (opcional, se queda dentro del espacio de rotación).

STANDARD



OPTIONAL



» FOR MORE INFO AND TECHNICAL DETAILS GO TO **EFFER PRODUCT GUIDE**

| DESCRIPTION | UNIT OF MEASURE | 3S | 4S | 5S | 6S | 8S | 9S |
|--|-----------------|--|-------|-------|-------|-------|-------|
| Max. hydraulic outreach Massimo sbraccio idraulico orizzontale Max. hydraulische Reichweite waagrecht Portée hydraulique horizontale maxi. Máximo alcance hidráulico horizontal | m | 10,55 | 12,74 | 15,15 | 17,37 | 20,86 | 23,24 |
| Max. lifting moment (+25°) Momento massimo di sollevamento (+25°) Max. Hubmoment (+25°) Moment de levage maxi. (+25°) Momento máximo de elevación (+25°) | kgm | 60210 | 59020 | 58370 | 57870 | 56360 | 56140 |
| | kNm | 590,7 | 579 | 572,6 | 567,7 | 552,9 | 550,7 |
| Slewing arc Angolo di rotazione Schwenkbereich Angle de rotation Ángulo de giro | (°) | endless / continua / endlos / sans fin / sin fin | | | | | |
| Slewing Capacity - Max slope Capacità di rotazione - Massima pendenza Rotationskapazität - Maximale Neigung Capacité de rotation - Pente Maxi Capacidad de rotación - Máxima inclinación | % | 8,7 | | | | | |
| Working pressure Pressione d'esercizio Betriebsdruck Pression de travail Presión de trabajo | bar | 350 | | | | | |
| Recommended oil delivery Portata d'olio consigliata Empfohlene Ölfördermenge Débit d'huile recommandé Caudal de aceite aconsejado | l/min | 100 | | | | | |
| Oil tank capacity Capacità serbatoio olio Öltankkapazität Capacité du réservoir d'huile Capacidad tanque de aceite | l | 260 | | | | | |
| Weight of the standard crane (± 2%) Peso gru standard (± 2%) Gewicht des Standardkranes (± 2%) Poids propre de la grue standard (± 2%) Peso grúa estandar (± 2%) | kg | 5635 | 5940 | 6215 | 6500 | 6980 | 7195 |



CRANE DESIGNED ACCORDING TO STANDARDS UNI EN 12999 HC1 S1 HD5

The configurations and figures contained in the brochure are illustrative. For information on the complete offer and for more technical details, ask your Effer dealer or consult the website www.effer.com. The above data are subject to change. Lifting capacity is based on the maximum lifting power of the crane. The stability of the truck may require a reduction of lifting capacity.

GRU PROGETTATA SECONDO NORME UNI EN 12999 HC1 S1 HD5

Le configurazioni e le immagini riportati nel depliant sono esemplificativi. Per conoscere l'offerta completa e per maggiori dettagli tecnici, rivolgersi al concessionario EFFER di zona e consultare il sito www.effer.com. I dati indicati possono subire modifiche. Capacità di sollevamento secondo potenza massima della gru. La stabilità dell'autocarro può richiedere il declassamento.

KRAN ENTWICKELT GEMÄSS UNI EN 12999 S1 HC1 S1 HD5

Die in der Broschüre enthaltenen Ausstattungen und Bilder dienen als Beispiel. Um das komplette Angebot zu kennen und für weitere technischen Informationen, wenden Sie sich an Ihren Händler EFFER und besuchen Sie unsere Homepage www.effer.com. Die geschriebenen Angaben können Änderungen vorsehen. Tragkraft gemäss maximale Kranleistung. Die Stabilität des Lastwagens kann die Deklassierung erfordern.

GRUE PROJETEE SELON LES NORMES UNI EN 12999 HC1 S1 HD5

Les configurations et les images contenues dans les dépliants sont exemplificatives. Pour connaître l'offre complète et les détails techniques, veuillez contacter votre revendeur EFFER et consulter le site www.effer.com. Les données indiquées peuvent subir des modifications. Capacité de levage selon la puissance maximum de la grue. La stabilité du véhicule peut nécessiter le déclassement.

GRÚA DISEÑADA SEGÚN LAS NORMAS UNI EN 12999 HC1 S1 HD5

Las configuraciones y las imágenes incluidas en el folleto se proporcionan a modo de ejemplo. Para conocer la oferta completa y para más detalles técnicos, consultar con el concesionario EFFER local y visitar el sitio web www.effer.com. Los datos indicados pueden sufrir modificaciones. Capacidad de elevación según la potencia máxima de la grúa. La estabilidad del camión puede requerir el desclasamiento.



EFFER S.p.A.

Via IV Novembre, 12 | 40061 Minerbio (BO) - Italy
Tel. +39 051 4181211 | Fax. +39 051 4181491
S.P. 40 ex Vicinale Accetta Grande | 74010 Statte (TA) - Italy
Tel +39 099 4700191 | Fax +39 09 9 4700189
www.effer.com | info@effer.it



Azienda certificata
Certificato n°
LRC 0160162/QMS