

DTA(S)-35/38/40

TELESCOPIC ARTICULATING AERIAL LIFT | INSULATED OR NON-INSULATED

DUR-A-LIFT

CATEGORIES
D & E
NOW AVAILABLE
TO MEET NEW
ANSI A92.2
STANDARDS



DTA-35 SHOWN WITH 11' BODY.



DTA-38 SHOWN WITH 11' BODY.



DTA-40 SHOWN WITH 11' BODY.

**DTA-38
FEATURES
SHORTER
STOWED
LENGTH
FOR USE
WITH A
9' OR 11'
BODY**



Working heights up to
45 FEET
AND SIDE REACH UP TO 29'6"

**SUPERIOR WORKING
HEIGHTS AND SIDE REACH**

**COMPACT DESIGN
AND STOWING**



sales@dur-a-lift.com
www.dur-a-lift.com

Dur-A-Lift Inc., P.O. Box 31, George, Iowa 51237
(877) 4-DURALIFT (877) 438-7254 | Fax: (712) 475-2809

DTA(S)-35/38/40

TELESCOPIC ARTICULATING AERIAL LIFT

SPECIFICATIONS

	DTA(S)-35	DTA(S)-38	DTA(S)-40
Height to bottom of platform	35'	38'	40'
Working height	40'	43'	45'
Side reach (SIDE HUNG)	25' 6"	25' 6"	27' 6"
Side reach (END HUNG)	27' 6"	27' 6"	29' 6"
Stowed travel height	10'	10'	10'
Basket capacity (SIDE HUNG)	400#	400#	400#
Basket capacity (END HUNG)	350#	350#	350#
Approximate weight	2400#	2615#	2750#
Articulating arm travel	-2 to 81	0 to 82	0 to 82
Main boom travel	-25 to 78	-25 to 78	-25 to 78
Extension travel	110.5"	110.5"	122.5"

Minimum GVWR will change significantly depending on make of chassis and stabilizer option. Dur-A-Lift Inc. reserves the right to improve models and change specifications without notice or obligation. Dur-A-Lift equipment meets or exceeds all applicable ANSI Standards as of the date of manufacture.

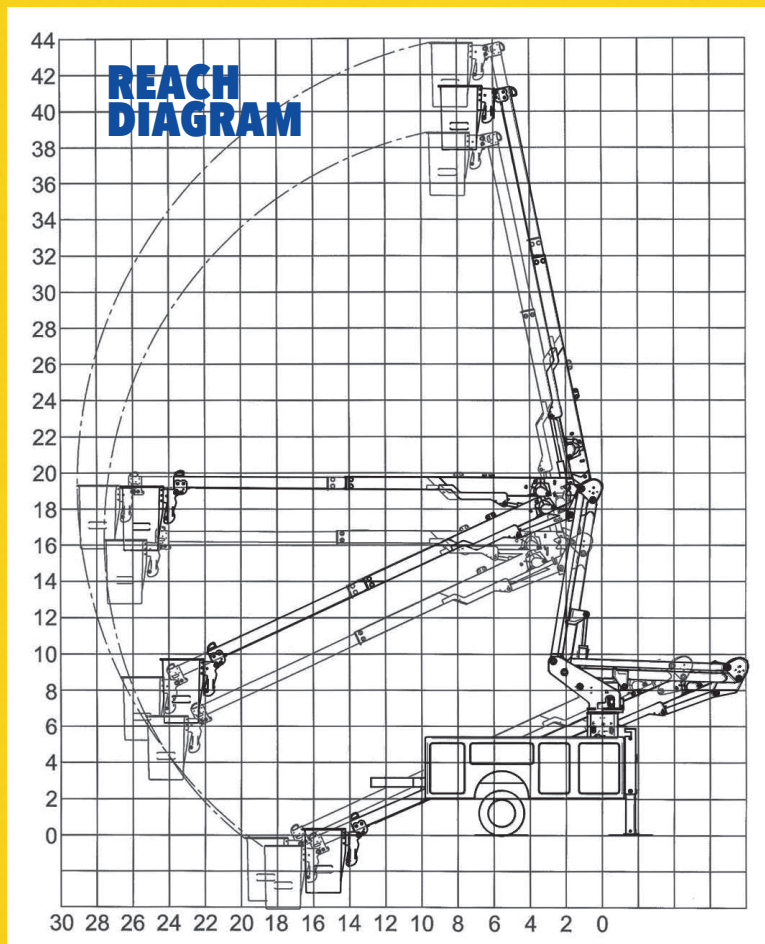

Basket shown in end hung position

CONTROLS

- Proportional controls
- Non-proportional controls **DTAS-35/38TS**
- Lower controls with override
- **Engine start/stop from the basket**
- Individual control levers

HYDRAULIC SYSTEM

- Rated pressure is 2200 PSI
- Operating pressure is 2000 PSI
- Open center hydraulic system

MECHANICAL SYSTEM

- **Telescoping articulating boom action**
- **Offset main boom reduces travel height**
- Shear ball rotation driven
- Fully enclosed worm gear box
- Non-continuous rotation
- Insulated extension boom **DTA**
- 24"x24"x42" basket
- Side hung basket

OPTIONS

- **Single hand joystick upper control**
- Outrigger or torsion bars
- 12v D.C. backup
- **End hung basket**
- Basket offered in various sizes and configurations
- Basket liner **DTA**
- Basket cover
- Continuous rotation **FULL PRESSURE SYSTEM**
- Tool trays of various sizes
- Tool circuits
- Tail shelf with walkup steps
- Main boom fiberglass insert **DTA**
- Articulating arm fiberglass insert **DTA**
- Paint color
- **Insulated option available** **DTAS**

This aerial lift is sold and serviced by:



sales@dur-a-lift.com
www.dur-a-lift.com

Dur-A-Lift Inc., P.O. Box 31, George, Iowa 51237
(877) 4-DURALIFT (877) 438-7254 | Fax: (712) 475-2809