



TECHNICAL SPECIFICATIONS

Pneumatic Diesel Forklift Trucks

D110/130/160S-5

25,000 lb to 36,000 lb Capacity

PRO5
SERIES



25,000/29,000/36,000 lb Capacities Engine Powered Forklift Trucks

Pneumatic Tire, Diesel

MAIN VEHICLE SPECIFICATIONS

	25,000	29,000	36,000	25,000	29,000	36,000	
CHARACTERISTICS	1	Manufacture		DOOSAN	DOOSAN	DOOSAN	
	2	Model		D110S-5	D130S-5	D160S-5	
	3	Load Capacity	at rated load center	in(kg)	25,000 (11,000)	29,000 (13,000)	36,000 (16,000)
	4	Load Center		in(mm)	24 (600)	24 (600)	24 (600)
	5	Power Type	Elec, Diesel, LPG, Gasoline		Diesel	Diesel	Diesel
	6	Operator Type			driver seated	driver seated	driver seated
	7	Tire Type	P: Pnu, E: Solid Soft, C: Cush		P	P	P
	8	Wheels (x=Driven)	Front / Rear		2 x 2 / 2	2 x 2 / 2	2 x 2 / 2
DIMENSIONS	9	Max. Fork Height	with STD 2-stage mast	in(mm)	118.0(3,000)	118.0(3,000)	118.0(3,000)
	10	Free Lift		in(mm)	0	0	0
	12	Fork Carriage	ISO Class		-	-	-
	13	Forks	Length x Width x Thickness	in(mm)	53.1 x 7.87 x 2.7 (1350 x 200 x 70)	53.1 x 7.87 x 3.3 (1350 x 200 x 85)	53.1 x 7.87 x 3.3 (1350 x 200 x 85)
			Fork Spacing(Min x Max)	in(mm)	18.5 x 84.2 (470 x 2,140)	18.5 x 84.2 (470 x 2,140)	18.5 x 90.2 (470 x 2,290)
	14	Tilt of Mast	Forward/Backward	deg	15 / 12	15 / 12	15 / 12
	15	Overall Dimensions	Length to Fork Face	in(mm)	170.9 (4,340)	170.9 (4,340)	187.0 (4,750)
	16		Overall Width	in(mm)	92.5 (2,350)	92.5 (2,350)	98.0 (2,490)
	17		Mast Lowered Height	in(mm)	117.0 (2,970)	117.0 (2,970)	124.8 (3,170)
	18		Mast Extended Height	in(mm)	176.0 (4,470)	176.0 (4,470)	183.9 (4,670)
	19		Overhead Guard Height	in(mm)	108.9 (2,765)	108.9 (2,765)	115.2 (2,928)
	20		Seat Height	in(mm)	65.4 (1,660)	65.4 (1,660)	71.6 (1,820)
	21	Turning Radius	Minimum outside	in(mm)	159.0 (4,040)	159.0 (4,040)	173.2 (4,400)
	22	Load Moment Center		in(mm)	29.7 (755)	29.9 (760)	32.0 (815)
	23	Aisle 90 degree stacking(add load length & clearance)		in(mm)	188.6 (4790)	188.6 (4790)	204.5 (5195)
PERFORMANCE	24	Travel Speed	Loaded/Unloaded	mph(km/h)	20.5/ 22.3 (33.0 / 36.0)	20.5/ 22.3 (33.0 / 36.0)	18.0 / 20.5 (29.0 / 33.0)
	25	Lifting Speed	Loaded/Unloaded	fpm(mm/s)	81 / 95 (410 / 480)	79 / 95 (400 / 480)	73 / 87 (370 / 440)
	26	Lowering Speed	Loaded/ Unloaded	fpm(mm/s)	94.5 / 84.6 (480 / 430)	94.5 / 84.6 (480 / 430)	84.6 / 80.7 (430 / 410)
	28	Max. drawbar pull	Loaded at 1.0 mph(1.6 km/h)	lb(kg)	17,813 (8,080)	17,813 (8,080)	22,928 (10,400)
	30	Max. gradeability	Loaded at 1.0 mph(1.6 km/h)	%	33.0	29.5	28.5
WEIGHT	32	Total Service Weight , Unloaded		lb(kg)	33,180 (15,050)	36,220 (16,430)	42,330 (19,200)
	33	Axle Load	Loaded, Front / Rear	lb(kg)	52,979/ 5,210 (23,490 / 2,560)	59,375/ 5,845 (26,660 / 2,770)	71,885 / 6,445 (31,870 / 3,330)
	34		Unloaded, Front / Rear	lb(kg)	16,005 / 17,175 (7,260 / 7,790)	16,445 / 19,775 (7,460 / 8,970)	19,135 / 23,195 (8,680 / 10,520)
CHASSIS	Tires	Number of wheels (F/R)		4 / 2	4 / 2	4 / 2	
		Size , Front		10.00 x 20 - 16PR	10.00 x 20 - 16PR	12.00 x 20 - 18PR	
		Size , Rear		10.00 x 20 - 16PR	10.00 x 20 - 16PR	12.00 x 20 - 18PR	
	Wheel Base	Distance	in(mm)	112.2 (2,850)	112.2 (2,850)	124.0 (3,150)	
	Tread Width	Front / Rear	in(mm)	67.8 / 73.2 (1,724 / 1,860)	67.8 / 73.2 (1,724 / 1,860)	71.8 / 75.2 (1,825 / 1,910)	
	Ground Clearance	Loaded at the lowest point	in(mm)	10.6 (270)	10.6 (270)	8.8 (224)	
		Loaded at center of wheelbase	in(mm)	14.2 (360)	14.2 (360)	14.3 (363)	
	Brakes	Service			Foot / Air	Foot / Air	Foot / Air
Parking				Hand / Air	Hand / Air	Hand / Air	
POWER TRAIN	Battery	Voltage / Ampere	V/AH	24(12 x 2) / 100	24(12 x 2) / 100	24(12 x 2) / 100	
	Engine	Manufacturer / Model		Doosan / DL06	Doosan / DL06	Doosan / DL06	
		Rated Power (DIN)	HP(PS)/rpm		138.0(140) / 2,100	138.0(140) / 2,100	157.8(160) / 2,100
			kW/rpm		103 / 2,100	103 / 2,100	117.8 / 2,100
		Maximum Torque	lb-ft/rpm		427.8 / 1,400	427.8 / 1,400	485.9 / 1,400
			kg-m/rpm		59.0 / 1,400	59.0 / 1,400	67.0 / 1400
	Transmission	Cylinders/ Displacements	in ³ (CC)	6 / 359.3 (5,890)	6 / 359.3 (5,890)	6 / 359.3 (5,890)	
		Type		Full Autoshift	Full Autoshift	Full Autoshift	
	Hydraulic Pressure	Number of Speed (Fwd/Rev)		3 / 3	3 / 3	3 / 3	
System		psi(bar)	2,755 (190)	2,755 (190)	3,045 (210)		
	Attachment	psi(bar)	2,030 (140)	2,030 (140)	2,030 (140)		

Note: Specification values quoted in this specification sheet has been rounded. Performance may vary due to operation conditions.

Products and specifications are subject to improvement and change without prior notices.

DIMENSIONAL DRAWING

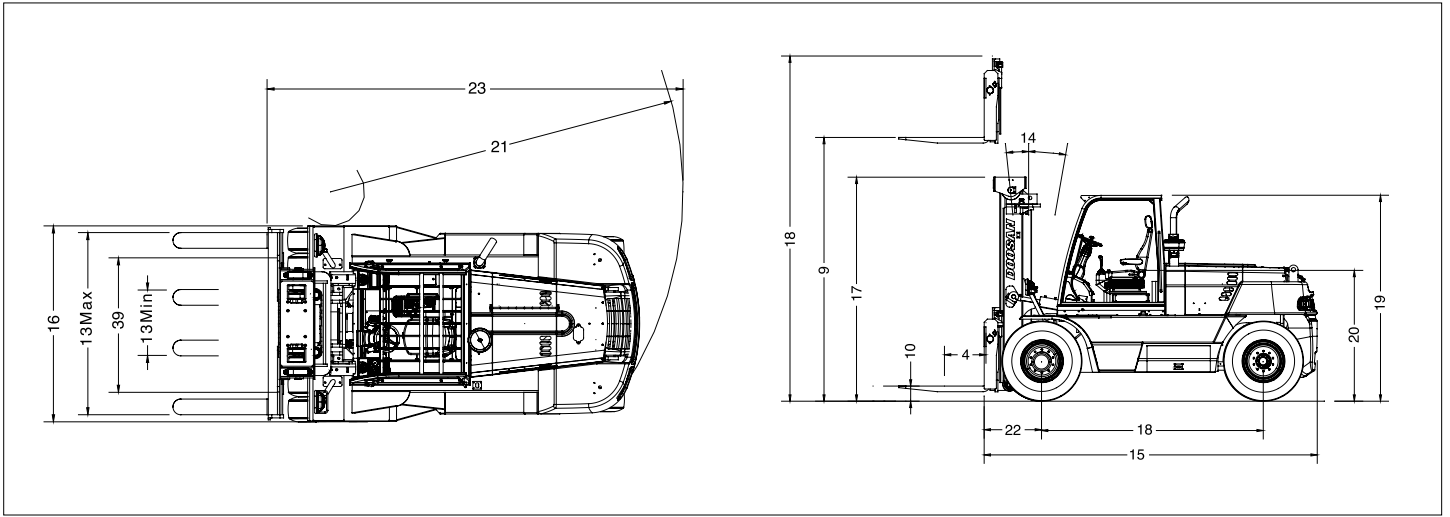

MAST SPECIFICATIONS and RATED CAPACITIES

Model	Mast Type	Maximum Fork Height		Fully Lowered Height		Fully Extended Height		Free Lift		Rated Load Capacities			
		mm	in	mm	in	With Load Backrest		With Load Backrest		Tilt Angle		LC 600mm kg	LC 24 in lb
						mm	in	mm	in	FWD deg	BWD deg		
D110S-5	STD	3000	118	2965	117	4465	176	0	0	15	12	11000	25000
		3500	138	3215	127	4965	195	0	0	15	12	11000	25000
		4000	157	3465	136	5465	215	0	0	15	12	11000	25000
		4500	177	3715	146	5965	235	0	0	15	12	11000	25000
		5000	197	4165	164	6665	262	0	0	15	12	11000	25000
		5500	217	4415	174	7165	282	0	0	15	12	10500	23850
		6000	236	4665	184	7665	302	0	0	15	12	9500	21600
D130S-5	STD	3000	118	2965	117	4465	176	0	0	15	12	13000	29000
		3500	138	3215	127	4965	195	0	0	15	12	13000	29000
		4000	157	3465	136	5465	215	0	0	15	12	13000	29000
		4500	177	3715	146	5965	235	0	0	15	12	13000	29000
		5000	197	4165	164	6665	262	0	0	15	12	13000	29000
		5500	217	4415	174	7165	282	0	0	15	12	12000	26750
		6000	236	4665	184	7665	302	0	0	15	12	11000	24550
D160S-5	STD	2900	114	2950	116	4400	173	0	0	15	12	16000	36000
		3000	118	3170	125	4670	184	0	0	15	12	16000	36000
		3500	138	3420	135	5170	204	0	0	15	12	16000	36000
		4000	157	3670	144	5670	223	0	0	15	12	16000	36000
		4500	177	3920	154	6170	243	0	0	15	12	16000	36000
		5000	197	4370	172	6870	270	0	0	15	12	16000	36000
		5500	217	4620	182	7370	290	0	0	15	12	15000	33750
		6000	236	4870	192	7870	310	0	0	15	12	14000	31500
	FFT	3700	146	2930	115	5335	210	1380	54	15	10	15000	33750
		4000	157	3030	119	5635	222	1480	58	15	10	15000	33750
		4500	177	3195	126	6130	241	1645	65	15	10	15000	33750
		5000	197	3360	132	6635	261	1815	71	15	10	15000	33750
		5500	217	3530	139	7135	281	1980	78	15	10	14400	32400
		6000	236	3695	145	7630	300	2145	84	15	10	13400	30150

Note: Mast specifications & Rated Capacities are based on standard chassis with pneumatic tire and without sideshifter.

● Standard Equipment

- Chassis with Doosan DL06 5.9 liter, Turbo-intercooler (Air Cooler), electric governed diesel Engine.
- 3 Speeds full autoshift transmission and inching system
- Fully hydraulic power steering with load sensing
- Integrated Instrument Panel
- Fully air actuated parking brake and service brake
- Deluxe suspension seat with retractable seat belt
- 2 front and rear flood lights and combination lamps
- Reinforced anisometric overhead guard rail for cabin
- Pilot operated lift/ tilt locking 2 spool hydraulic Valve
- High visibility 2 stage 3000 mm(118 in) Mast
- Dual element air cleaner
- 15. Forward / 12. Backward tilt cylinders.
- 1350 mm (53 in) length forks

● Mast

- Doosan forklift trucks offer a full range of wide view masts;
- STD double mast : 3.0m(118 in) ~ 6.0m(236 in)
 - FFT triple full free mast : 3.7m(145 in) ~ 6.0m(246 in) ;
Suitable for stacking applications in areas with limited height clearance but where maximum lift is also required.
(Available on D160S-5 only)
- All masts are steel weldment uprights with rigid cross members for strength and reliability. Secondary lift cylinders have cushioning valves to ensure smooth and silent staging during lifting and lowering.

● Carriage

D110/130/160S-5 series is equipped with high tensile shaft mounting type carriage. An optional integrated sidershifter and fork mover is also available.

● Full Range Electric Governed Turbocharger Doosan DL06 5.9 liter Diesel Engine

The powerful and reliable 6 cylinder Doosan DL06 5.9 liter diesel engine provides excellent performance for even the toughest applications. Doosan DL06 diesel engine complies with EPA Tier III and Euro Stage 3 emission regulation. High fuel injection system pressure, 4 valves per cylinder and CAC(Charged Air Cooler) turbocharger maximizes engine performance with low fuel consumption rates. The ECU(Engine Control Unit) controls basic engine output functions, such as proper and optimum AFR(Air to Fuel Ratio), engine torque and speeds. The ECU also protects the engine from abnormal engine conditions, such as 'High Engine Coolant Temp' and 'Low Engine Oil Pressure'.

● Full Autoshift Transmission and Electric Inching System

The electric control module of the transmission automatically changes truck travel speed based on the engine speed and the load on the drive wheels. With its advanced electric control system, operator is free from the inconvenience of gear shifting while driving. Also operator can select various operating modes, such as manual shifting, starting at low speed gear shifting or at high speed gear shifting depending on application needs. The self-diagnostics and easy check-up functions will reduce the time to troubleshoot any problems.

The electric inching system permits even massive loads to be moved with great precision. It is controlled by selection switch

activated by the operator.

● Rugged Drive Axle

Planetary gear drive axle consists of four pinion and hypoid differential gears and radial sun and ring gears with steel housing, hardened load bearing spindle and full-floating axle shaft to protect from high impact shock loading. Gears and bearings are positively lubricated by oil flow.

● Air Shoe Brakes

Large diameter and self-adjusting non-asbestos shoe brakes are provided as standard equipment. The fully air-actuated shoe brakes are boosted by large double air- compressed chambers. S-cam type mechanism provides secure brake force with low brake pedal effort. For operating safety this brake system adopts power-off system, self-lock brake system, which activates the air-parking brake in case of brake line malfunction.

● Side Tiltable Operator Compartment and Cab

Easy access to powertrain components is facilitated by activating the side tiltable operator compartment or optional cab at the touch of a button . The hydraulic actuated cylinder tilts operator compartment or cab to right side about 65 degrees for easy service access.

● Operator Area

Large, anti-skid open steps and long hand grips welded on overhead guard strut provide easy operator access to and from the seat. Infinitely adjustable tilt steer column, and deck-mounted pilot operated hydraulic control levers, ensure operator comfort and reduced fatigue. 6 direction adjustable, operator weight adjustment full-suspension deluxe seat provides comfortable working positions for all sizes of operators. The integrated easy-to-read instrument panel alerts the operator to all truck conditions at a glance from their seated position.

● Optional Equipment

- Solid Soft Tires
- Tiltable Operator Compartment and Deluxe Operator Cab
- Operator Comfort Features with Operator Cab
 - Air Conditioner / Heater
 - Sound Suppression Package
 - CD Player & Radio for Cabin
- Pilot Operated 3/4/5 Spools Hydraulic Control Valve
- Integral Sidershifter or Integral Sideshifting Fork Positioner
- 4 Working Lights
- 2 Front Lights on Fender
- Rear Strobe Lamp / Spark Arrestor
- Catalytic Muffler
- Battery Isolated Switch
- Lockable Fuel Cap

