

TH357D, TH408D, TH3510D

Ag Handler Telehandlers



Part of the All New Cat® Ag Product Range

	TH357D		TH408D		TH3510D	
Engine Power						
Gross Power @ 2,200 rpm	83 kW	111 hp	83 kW	111 hp	83 kW	112 hp
	92.6 kW	124 hp	92.6 kW	124 hp	93 kW	124 hp
			106 kW	142 hp	106 kW	142 hp
Lift and Reach						
Maximum Lift Height	7.0 m		7.6 m		9.8 m	
Maximum Forward Reach	3.65 m		4.3 m		6.6 m	
Lift Capacity						
Rated Load Capacity	3500 kg		4000 kg		3500 kg	
Capacity at Maximum Height	2250 kg		2025 kg		770 kg	
Capacity at Maximum Reach	1500 kg		1400 kg		500 kg	

Configured for Success

Whether you are lifting at height or working in low buildings, Cat® Telehandlers offer a size class to suit your application.

Work Made Easy

Get work done faster and safer with class leading cycle times and all-around visibility. Proportional controls and adjustable hydraulic speeds ensure precision as well as speed.

Enjoy All Day Comfort

Enjoy outstanding comfort and convenience in the D Series cab as well as one of the smoothest rides on the farm.

Efficiently Powerful

Experience outstanding fuel efficiency and power, giving you responsive hydraulics and lift capacity only when you need it. The accessible diesel exhaust fluid (DEF) refill point ensures after-treatment services are as simple as possible.

Safe and Secure

Feel secure in one of the most stable telehandlers in the market, with built in stability sensors. Excellent visibility as well as optional reversing sensors and rear-view camera act as an extra pair of eyes. The anti-theft system helps protect your machine when left unattended.

Contents

Configured for Success4

Customize Your Experience.....6

Efficiently Powerful.....8

Work Made Easy.....9

Handle the Toughest Terrain10

Safe and Secure.....11

Enjoy All Day Comfort.....12

Multi Function Display Screen.....13

Ride Control and Boom Float13

Defiantly Durable14

Customer Support.....15

Specifications.....16

Standard and Optional Equipment28

Notes.....30





Since the 1980s Caterpillar has been producing high quality Telehandlers, beginning with the RT Series, and always designed with the operator in mind. Providing reliability, competitive performance and a high quality operator environment, Cat Telehandlers are truly the work horse of any farm. Over 25 years of progress have produced the outstanding quality found only in Cat TH D Series Telehandlers.

Configured for Success

Providing a solution to any task.



TH357D



TH408D

Maximum Lift Height
Rated Load Capacity

7.0 m
3500 kg

7.6 m
4000 kg



TH3510D

9.8 m

3500 kg

Versatility

Our Cat Telehandler range is designed to provide operators with a number of machine choices, selecting the size class best suited to getting the job done. Each machine has been precision engineered to handle a range of tasks, offering stability, maneuverability, speed and power in any application.

Offering a Complete Solution

In addition to couplers and work tools, there are numerous tire options to help protect against wear and provide maximum traction on different surfaces. Caterpillar also provides an array of towing hitches. Within the cab you can customize seating, controls such as F-N-R positioning and various additions such as a display screen, reversing camera and sunblinds.

The Right Tool for the Job

Whether you need to stack bales or load trailers, Cat Telehandlers have an attachment to get the job done. Bale grabs, buckets, pallet forks, manure forks and lifting tools can be attached to a manual or hydraulic coupler. For customers with an existing range of work tools, a coupler can be fitted to match your interface requirements. Utilizing a Z-bar linkage to improve coupler rotation and breakout force, Cat Telehandlers help you get the job done quicker.

Customize Your Experience

Tailored to your farm.



Reversing Camera

The reversing camera option automatically displays a live image from behind the machine, integrated into the multi function display, when reversing. Whether parking, checking your surroundings or squeezing through a narrow gap, the reversing camera acts as an extra pair of eyes on-site. In addition, an optional reversing sensor can be fitted, creating an audible warning the closer you get to objects, similar to those fitted in modern cars.



New Multi Function Joystick

The multi function joystick features F-N-R and hydraulic functions, including auxiliaries and gear shift. Simultaneous hydraulic and power train operation has never been easier.

Optimize Your Work Space

Optional steering column-mounted F-N-R, customizable hydraulic speed, lockable travel speed and a range of cab options including seating and radio ready cabs make the Cat Telehandler cab a seat that is truly your own. Dash board features an ergonomic control layout as well as a new LED dash display featuring fuel and speed readings.

Adjustable Settings

The ability to adjust settings such as hydraulic speed helps operators of all levels work comfortably. Operator preference settings in the cab mean that the hydraulic controls can be adjusted for quicker or slower response.



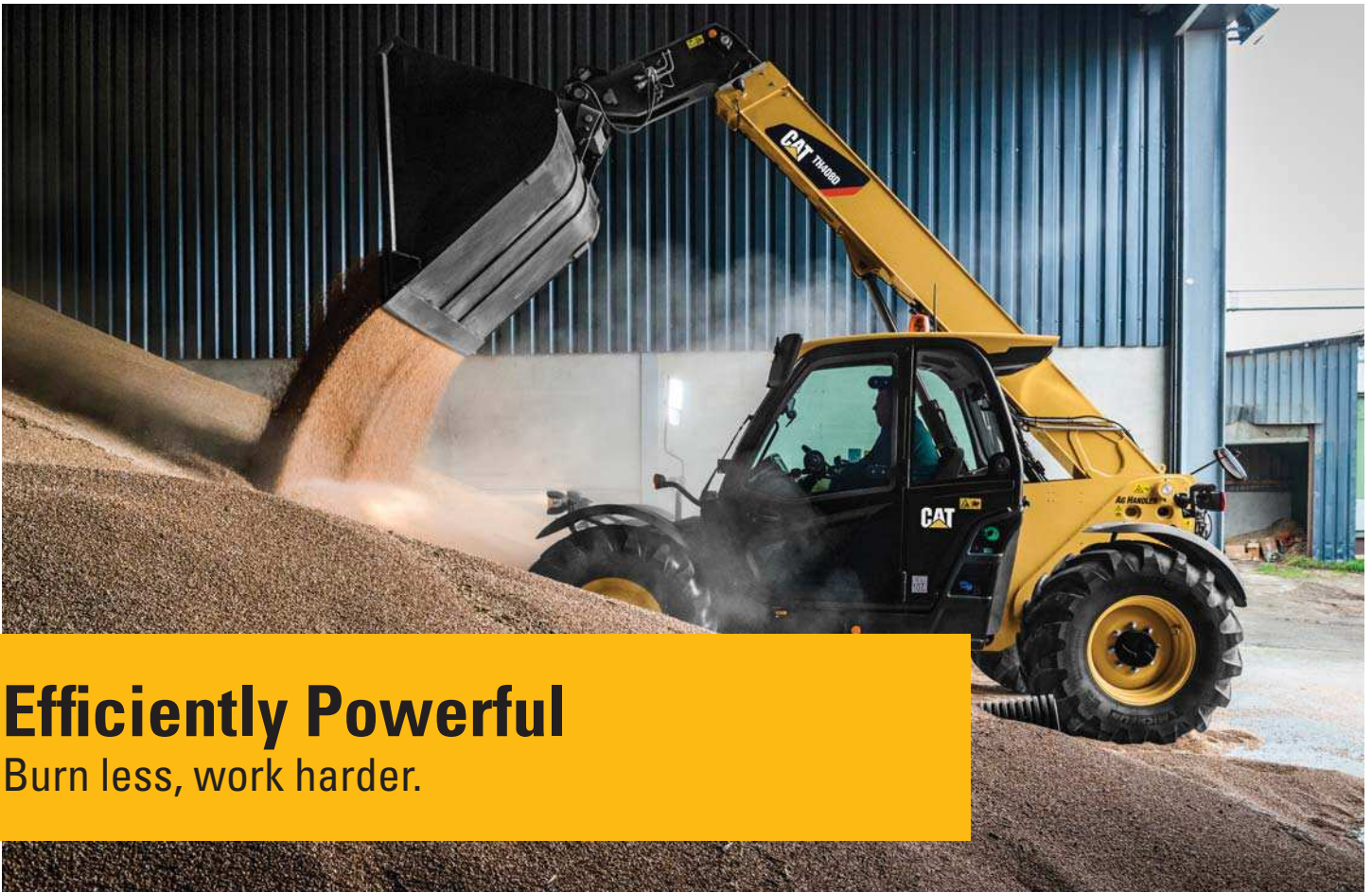

Efficiently Powerful

Burn less, work harder.

Emissions

The engines meet EU Stage IV emission standards, utilizing DOC/SCR aftertreatment. No diesel particulate filter (DPF) is required. Maintenance is easy, simply refill the diesel exhaust fluid and continue working.

Power on Demand

Due to the load sensing hydraulics, the Cat Telehandler only burns fluids when required and has excellent hydraulic flow at low idle, meaning you only consume fluids when truly needed.

Breathing Clean

Available both on demand via an in-cab switch and at customizable scheduled intervals, the hydraulic reverse demand fan will blow dust and debris away from the cooling package, decreasing servicing requirements.

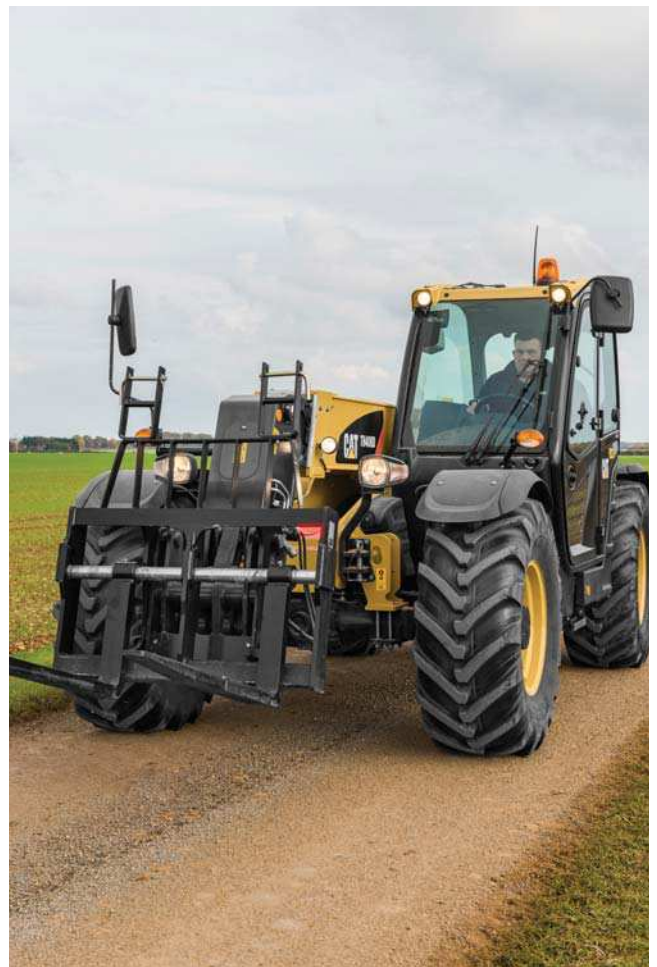

Work Made Easy

Power and precision when you need it most.



Optimized Z-Bar Linkage

The optimized Z-bar linkage combines precision lifting capability with excellent coupler rotation and fast bucket speeds, perfect for a wide range of bucket work applications. Providing strong breakout force and excellent tilt angles, the Z-bar linkage is ideal for a range of agricultural applications.

Work Faster

Class leading cycle times and fast hydraulics help you get the job done faster. Flow sharing valves and a variable displacement pump on the TH357D, TH408D and TH3510D models ensure rapid hydraulics even at low idle, meaning simple and quick hydraulics.

Passive and Active Stability System

Cat Telehandlers are fitted with a longitudinal stability indicator (LSI) designed to warn operators and prevent tipping. Our unique system responds to the application allowing the operator to get the most out of the machine. When the boom is fully retracted, the park brake is off, and the transmission is in forward or reverse, the machine LSI enters 'passive mode.' This means the hydraulics will not lock out, only a visual and audible warning is displayed. This feature is perfect for driving into piled material, allowing for faster bucket work and more productive operation.

Comfortable Softened Hydraulics

Our cylinder snubbing design ensures the last section of retracting and lowering the boom is softened, providing comfort and less wear on the boom.

Handle the Toughest Terrain

The traction and braking for any conditions.



Tackle Any Obstacle

Take advantage of unrivalled stability, ensuring comfort and stable load carrying even on unlevel ground. Limited slip differential, excellent ground clearance and permanent four wheel drive allow you to conquer even the most difficult terrain. Uneven ground and piled material such as silage are easy to handle. Dual axle braking further improves safety for operators on steep gradients and in poor conditions (on TH357D, TH408D, and TH3510D only).

Maneuverability and Raw Power

The TH357D, TH408D and TH3510D offer powerful hydraulics and excellent towing ability, making them the perfect machines for any job on the farm.

Keep Moving

Cat Telehandlers feature joystick-mounted F-N-R, allowing rapid change from forward to neutral and reverse. Tight turning angles of the wheels result in a competitive turning circle, in addition to class leading stability.

Smooth and Secure Towing

The stability of bales and other loads on a trailer is critical, as is the comfort and stability of the machine you drive. Cat Telehandlers feature a short rear axle to hitch distance meaning less instability when towing a trailer.



"The TH408D has plenty of power when using a bucket and piling material. The stability and power when towing helps us to move trailers around the farm easily."

– Newark, United Kingdom

Safe and Secure

Stability, reliability and protection.



Longitudinal Stability Indicator

The longitudinal stability indicator (LSI) warns you when a load is potentially threatening to the stability of the machine, stopping the boom functionality when reached, allowing you to safely bring the load in.

Reliable and Safe

With the ability to run diagnostics checks on the machine, the multi function display screen makes regular maintenance simple. The reversing camera option also provides an added range of visibility, helping you judge your distance with 1.5 m (5 ft) and 4.5 m (15 ft) line markings.

Settings and Options

The D Series machines give the operator more control than ever, with selectable driving modes and scheduled intervals for the reversing hydraulic demand fan. Guards for the roof and windscreen help protect from external objects or hazards.

Anti-Theft Protection

Programmable codes provide an added layer of protection on the farm. You can have piece of mind that your machine is well secured from potential theft.

Enjoy All Day Comfort

A quiet, comfortable, convenient operator environment.

Sit Back and Experience:

- **A Quiet, Spacious Operator Environment** featuring ergonomic controls. In-cab noise levels reach only 75 dB(A), a comfortable working volume even during long days.
- **The Smoothest Ride on the Farm** while travelling and operating. The ride control feature combined with class leading stability, due to a long wheel base, ensures a smooth driving experience. Rough terrain and long distances are hardly felt from the comfort of the cab.
- **An Adjustable Armrest** that allows operators to customize their operating position, improving comfort and seating position throughout the day.
- **Superior Visibility** to the rear and right hand side of the machine from a lowered boom pivot point and raised cab height. An optional reversing camera provides great all around visibility.
- **Enhanced Air Conditioning and Heating** in both power and heating or cooling range. From inside the cab you can remain comfortable, no matter what the conditions outside are like.



Multi Function Display Screen

Diagnostics, load charts and reversing camera.

Operators who select the multi function display screen option have access to a multitude of information, right at their fingertips. Load charts, maintenance schedules and the reversing camera image are all available to the operator. The display also allows for customization of the reversing fan intervals and selections such as hydraulic speed and default gear.



Ride Control and Boom Float

The most comfortable seat on the farm.



When travelling over uneven ground or at speed (5 kph/3 mph or above) the ride control feature acts to improve boom control, improving operator comfort and control, as well as machine load retention, particularly with a bucket or when carrying loose material. The boom float feature enables the attachment to follow the contours of the ground, while the operator has free movement of the boom lift and lower functions.

Defiantly Durable

Simple servicing, reduced maintenance.



Daily Service Points

To help you service your machine quickly and easily, daily service points are all within easy access. Fill points, air cleaner, washer bottles, etc. are accessible from ground level.

Cooling Pack

Designed to meet the needs of the agricultural industry, the large cooling pack on Cat Telehandlers also features a hydraulic reverse demand fan to help reduce maintenance costs.

Cat Filters

Cat filters are vertically mounted for spill-free servicing and reduced oil contamination. These low micron filters remove microscopic particles from the oil. Vertical mounting on filters also makes them easy to remove and access.

Extended Intervals

To reduce service time and maximize uptime our hydraulic oil service intervals have been increased by 500 hours, making sure you get the most out of your machine, and keep maintenance costs down.

Product Link™

Machines can be Product Link ready to facilitate PL641 dealer installation, with a subscription to VisionLink® available to help track machine location and trigger servicing intervals.

Reduced Maintenance

Ensure servicing time and costs at a minimum with extended filter cleaning intervals, a reversing fan to cleanse the engine, large and vertically spaced cooling package and easy to access parallel mounted engine.



Customer Support

Dealer services and solutions.

Customer Support Agreements

Your Cat dealer can offer a comprehensive range of Customer Support Agreements that can be individually tailored to suit your finances and requirements. Dealers can offer a range of options from a basic service to a full preventative maintenance solution. Protect your valuable investment and know exactly what your monthly payments will be to help you run your business.

Finance

Have you explored the range of options available from your dealer to finance your machine? They can offer a selection of attractive packages tailored to suit your every requirement.

Machine Selection

Your dealer can help you with your machine purchase decision based on your requirements and help keep operating costs to a minimum. Work tools and options can all be discussed with your local dealer.

Training and Support

Speak to your Cat dealer about additional support they can offer. They can advise you on operating techniques for your machine that will minimize wear and tear, maximize productivity, lower owning and operating costs and help you make the most of the fantastic features offered on Cat Telehandlers.

TH357D Ag Handler Telehandler Specifications

Engine

	Standard	
Model*	Cat C3.4B	
Gross Power	83 kW	111 hp/bhp
Maximum Torque	460 N·m	
Bore	99 mm	
Stroke	110 mm	
Displacement	3.4 L	

	Option 1	
Model*	Cat C4.4 ACERT™	
Gross Power	92.6 kW	124 hp/bhp
Maximum Torque	530 N·m	
Bore	105 mm	
Stroke	127 mm	
Displacement	4.4 L	

*Meets EU Stage IV emission standards.

Air Conditioning System

The air conditioning system on this machine contains the fluorinated greenhouse gas refrigerant R134a (Global Warming Potential = 1430). The system contains 1.2 kg of refrigerant which has a CO₂ equivalent 1.575 metric tonne.

Weights

Operating Weight with Carriage and Forks* 7785 kg

*Represents machine configuration of 83 kW (111 hp/bhp) engine on standard 15.5/80-24 16 ply tires.

Operating Specifications

Rated Load Capacity	3500 kg
Maximum Lift Height	7.0 m
Capacity at Maximum Lift Height	2250 kg
Maximum Forward Reach	3.65 m
Capacity at Maximum Forward Reach	1500 kg
Outside Turning Radius over Tires	3.85 m
Outside Turning Radius over Forks	3.95 m

Service Refill Capacities

Fuel Tank	148 L
Diesel Exhaust Fluid	19 L
Hydraulic Tank	120 L

Brakes

Service Brakes	Boost assisted oil immersed multi disc on both axles
Parking Brake	Mechanically actuated on front axle service brakes

Transmission

Type	4 speed power shift
Forward	
1	5.8 km/h
2	8.6 km/h
3	11.3 km/h
4	16.7 km/h
5	25.4 km/h
6	40 km/h*
Reverse	
1	5.8 km/h
2	11.3 km/h
3	25.4 km/h

*Maximum speed subject to machine configuration.

Electrical

Battery	1 × 12V 1,000 CCA Battery
Alternator Output	12V/150A

Hydraulic System

System Type	Load Sensing, Closed Center
Pump Type	Variable Flow, Axial Piston
Maximum Pump Capacity	140 L/min
System Pressure	260 bar
Auxiliary Hydraulic Pressure	245 bar
Auxiliary Hydraulic Flow	
Boom Head – Intermittent	95 L/min
Boom Head – Continuous	95 L/min
Machine Rear	80 L/min

TH357D Ag Handler Telehandler Specifications

Boom Performance

Boom Up	6.5 sec
Boom Down	5.8 sec
Tele Out	5.5 sec
Tele In	5.5 sec
Crowd Forward (Dump)	3 sec
Crowd Backward	3 sec
Combined – Up and Out	10.2 sec
Combined – Down and In	8.2 sec

Axles

Front Axle	High bias, planetary reduction hubs with limited slip differential
Rear Axle	Open differential with planetary reduction hubs

Tires

Standard	Mitas 15.5/80-24 16 ply
Options	Michelin 15.5 R25 XHA Michelin 460/70 R24 XMCL Michelin 500/70 R24 XMCL Michelin 440/80 24 Power CL Michelin 400/80 24 Power CL Michelin 460/70 R24 Bibload Firestone Duraforce 13 × 24 Solid Tires

Performance

Drawbar Pull	
83 kW/111 hp Engine	92 kN
93 kW/124 hp Engine	88 kN
Boom Breakout Force	50 kN
Bucket Breakout Force	72 kN
Quick Coupler Rotation	152°
Noise Levels	
In Cab	74 dB(A)
External	106 dB(A)
Towable Mass	
Hydraulically Braked	12 000 kg

TH408D Ag Handler Telehandler Specifications

Engine

	Standard	Option 1	Option 2
Model*	Cat C3.4B	Cat C4.4 ACERT	Cat C4.4 ACERT
Gross Power	83 kW 111 hp/bhp	92.6 kW 124 hp/bhp	106 kW 142 hp/bhp
Maximum Torque	460 N·m	530 N·m	560 N·m
Bore	99 mm	105 mm	105 mm
Stroke	110 mm	127 mm	127 mm
Displacement	3.4 L	4.4 L	4.4 L

*Meets EU Stage IV emission standards.

Air Conditioning System

The air conditioning system on this machine contains the fluorinated greenhouse gas refrigerant R134a (Global Warming Potential = 1430). The system contains 1.2 kg of refrigerant which has a CO₂ equivalent 1.575 metric tonne.

Weights

Operating Weight with Carriage and Forks* 8526 kg

*Represents machine configuration of 106 kW (142 hp/bhp) engine on standard 15.5/80-24 16 ply tires.

Operating Specifications

Rated Load Capacity	4000 kg
Maximum Lift Height	7.6 m
Capacity at Maximum Lift Height	2025 kg
Maximum Forward Reach	4.3 m
Capacity at Maximum Forward Reach	1400 kg
Outside Turning Radius over Tires	3.85 m
Outside Turning Radius over Forks	4.53 m

Service Refill Capacities

Fuel Tank	148 L
Diesel Exhaust Fluid	19 L
Hydraulic Tank	120 L

Brakes

Service Brakes	Boost assisted oil immersed multi disc on both axles
Parking Brake	Mechanically actuated on front axle service brakes

Transmission

Type	Cat PG124 6 speed power shift
Forward	
1	5.8 km/h
2	8.6 km/h
3	11.3 km/h
4	16.7 km/h
5	25.4 km/h
6	40 km/h*
Reverse	
1	5.8 km/h
2	11.3 km/h
3	25.4 km/h

*Maximum speed subject to machine configuration.

Electrical

Battery	1 × 12V 1,000 CCA Battery
Alternator Output	12V/150A

Hydraulic System

System Type	Load Sensing, Closed Center
Pump Type	Variable Flow, Axial Piston
Maximum Pump Capacity	140 L/min
System Pressure	260 bar
Auxiliary Hydraulic Pressure	245 bar
Auxiliary Hydraulic Flow	
Boom Head – Intermittent	95 L/min
Boom Head – Continuous	95 L/min
Machine Rear	80 L/min

TH408D Ag Handler Telehandler Specifications

Boom Performance

Boom Up	7.2 sec
Boom Down	5.5 sec
Tele Out	6 sec
Tele In	5.3 sec
Crowd Forward (Dump)	3.5 sec
Crowd Backward	2.9 sec
Combined – Up and Out	10.7 sec
Combined – Down and In	8.7 sec

Axles

Front Axle	High bias, planetary reduction hubs with limited slip differential
Rear Axle	Open differential with planetary reduction hubs

Tires

Standard	Mitas 15.5/80-24 16 ply
Options	Michelin 15.5 R25 XHA Michelin 460/70 R24 XMCL Michelin 500/70 R24 XMCL Michelin 440/80 24 Power CL Michelin 400/80 24 Power CL Michelin 460/70 R24 Bibload Firestone Duraforce 13 × 24 Solid Tires

Performance

Drawbar Pull	
83 kW/111 hp Engine	92 kN
93 kW/124 hp Engine	88 kN
106 kW/142 hp Engine	97 kN
Boom Breakout Force	46 kN
Bucket Breakout Force	72 kN
Quick Coupler Rotation	152°
Noise Levels	
In Cab	74 dB(A)
External	106 dB(A)
Towable Mass	
Hydraulically Braked	12 000 kg

TH3510D Ag Handler Telehandler Specifications

Engine

	Standard	Option 1	Option 2
Model*	Cat C3.4B	Cat C4.4 ACERT	Cat C4.4 ACERT
Gross Power	83 kW 112 hp/bhp	93 kW 124 hp/bhp	106 kW 142 hp/bhp
Maximum Torque	460 N·m	530 N·m	560 N·m
Bore	99 mm	105 mm	105 mm
Stroke	110 mm	127 mm	127 mm
Displacement	3.4 L	4.4 L	4.4 L

*Meets EU Stage IV emission standards.

Air Conditioning System

The air conditioning system on this machine contains the fluorinated greenhouse gas refrigerant R134a (Global Warming Potential = 1430). The system contains 1.2 kg of refrigerant which has a CO₂ equivalent 1.575 metric tonne.

Weights

Operating Weight with Carriage and Forks* 9149 kg

*Represents machine configuration of 106 kW (144 hp/bhp) engine on standard 15.5/80-24 16 ply tires.

Operating Specifications

Rated Load Capacity	3500 kg
Maximum Lift Height	9.8 m
Capacity at Maximum Lift Height	770 kg
Maximum Forward Reach	6.6 m
Capacity at Maximum Forward Reach	500 kg
Outside Turning Radius over Tires	3.85 m
Outside Turning Radius over Forks	4.88 m

Service Refill Capacities

Fuel Tank	148 L
Diesel Exhaust Fluid	19 L
Hydraulic Tank	120 L

Brakes

Service Brakes	Boosted on front and rear brakes
Parking Brake	Mechanical lever on front axle

Transmission

Type	Cat PG124 6 speed power shift
Forward	
1	5.7 km/h
2	8.6 km/h
3	11.2 km/h
4	16.6 km/h
5	25.3 km/h
6	40 km/h*
Reverse	
1	5.7 km/h
2	11.2 km/h
3	25.3 km/h

*Maximum speed subject to machine configuration.

Electrical

Battery	1 × 12V 1,000 CCA Battery
Alternator Output	12V/150A

Hydraulic System

System Type	Load Sensing, Closed Center
Pump Type	Variable Flow, Axial Piston
Maximum Pump Capacity	140 L/min
System Pressure	260 bar
Auxiliary Hydraulic Pressure	245 bar
Auxiliary Hydraulic Flow	
Boom Head – Intermittent	95 L/min
Boom Head – Continuous	95 L/min
Machine Rear	80 L/min

TH3510D Ag Handler Telehandler Specifications

Boom Performance

Boom Up	8 sec
Boom Down	6.5 sec
Tele Out	11 sec
Tele In	10.5 sec
Crowd Forward (Dump)	3 sec
Crowd Backward	3.5 sec
Combined – Up and Out	24 sec
Combined – Down and In	12.8 sec

Axles

Front Axle	High bias, planetary reduction hubs with limited slip differential
Rear Axle	Open differential with planetary reduction hubs

Tires

Standard	Mitas 15.5/80-24 16 ply
Options	Michelin 15.5 R25 XHA Michelin 460/70 R24 XMCL Michelin 500/70 R24 XMCL Michelin 440/80 24 Power CL Michelin 400/80 24 Power CL Michelin 460/70 R24 Bibload Firestone Duraforce 13 × 24 Solid Tires

Performance

Drawbar Pull	
83 kW/111.3 hp Engine	92 kN
93 kW/124.1 hp Engine	88 kN
106 kW/142.1 hp Engine	97 kN
Boom Breakout Force	41 kN
Bucket Breakout Force	62 kN
Quick Coupler Rotation	152°
Noise Levels	
In Cab	74 dB(A)
External	106 dB(A)
Towable Mass	
Hydraulically Braked	12 000 kg

TH357D, TH408D, TH3510D Ag Handler Telehandlers Specifications

Dimensions

All dimensions are approximate.

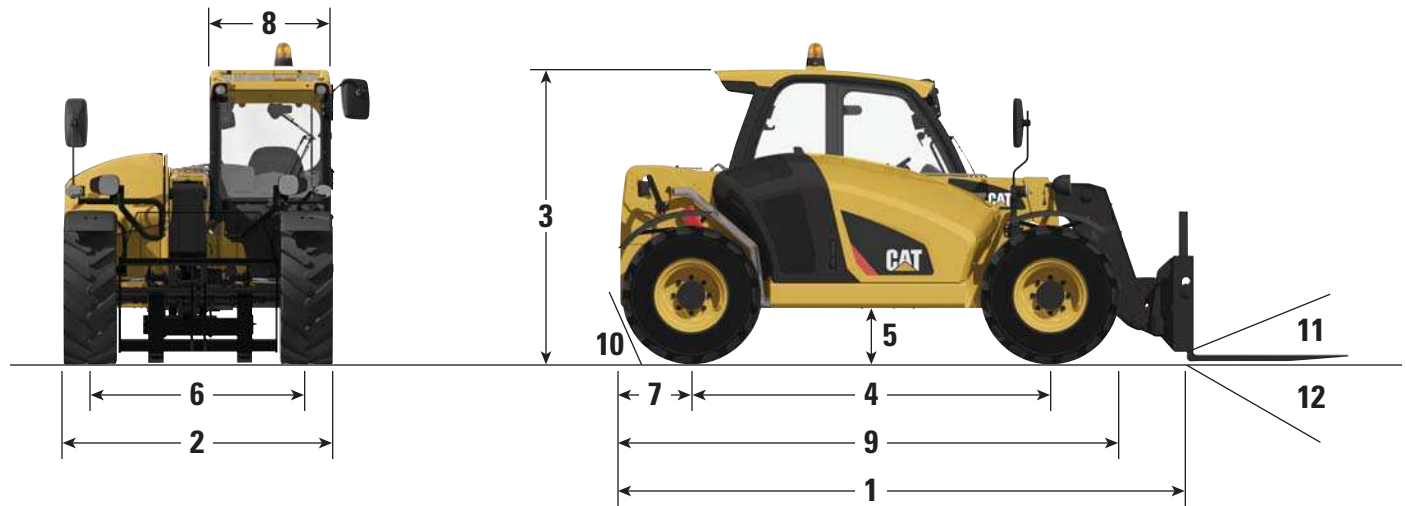

	TH357D	TH408D	TH3510D
1 Overall Length to Front of Carriage	5000 mm	5286 mm	5300 mm
2 Overall Width (standard tires)	2382 mm	2382 mm	2382 mm
3 Overall Height (standard tires)*	2475 mm	2475 mm	2475 mm
4 Wheelbase	3165 mm	3165 mm	3165 mm
5 Ground Clearance	430 mm	430 mm	430 mm
6 Track	1988 mm	1988 mm	1988 mm
7 Overhang	1000 mm	1000 mm	1000 mm
8 Cab Width	900 mm	900 mm	900 mm
9 Machine Length	5000 mm	5260 mm	5260 mm
10 Departure Angle	60°	60°	60°
11 Maximum Fork Crowd Angle	24°	24°	24°
12 Maximum Fork Dump Angle	128°	128°	128°

*Add 200 mm for beacon.
Add 40 mm for top guard.

TH357D Ag Handler Telehandlers Specifications

Load Charts

TH357D Ag Handler

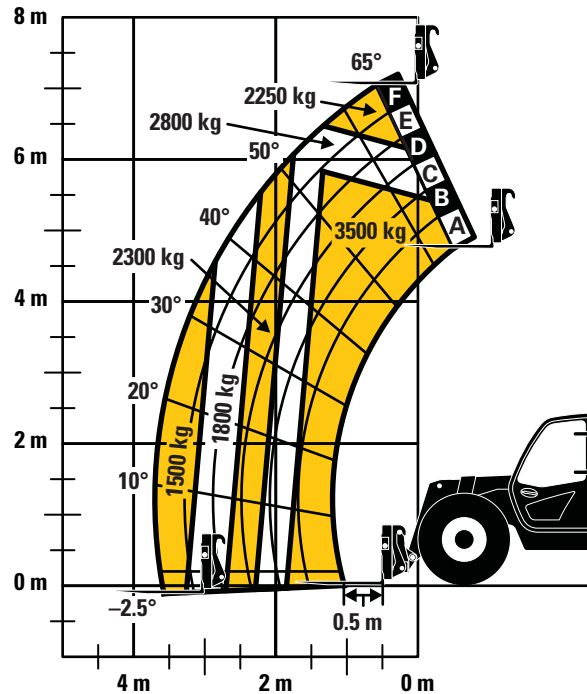

IMPORTANT

Rated lift capacities shown are with machine equipped with carriage and pallet forks. The machine must be level on a firm surface with undamaged, properly inflated tires. Machine specifications and stability are based on rated lift capacities at specific boom angles and boom lengths. (If specifications are critical, the proposed application should be discussed with your dealer.)

DO NOT exceed rated lift capacity loads, as unstable and dangerous machine conditions will result.

DO NOT tip the machine forward to determine the allowable load.

Use only approved attachments with proper material handler model/attachment load capacity charts displayed in the operator's cab.

Due to continuous product improvements, machine specifications and/or equipment changes may be made without prior notification.

TH408D, TH3510D Ag Handler Telehandlers Specifications

Load Charts

TH408D Ag Handler

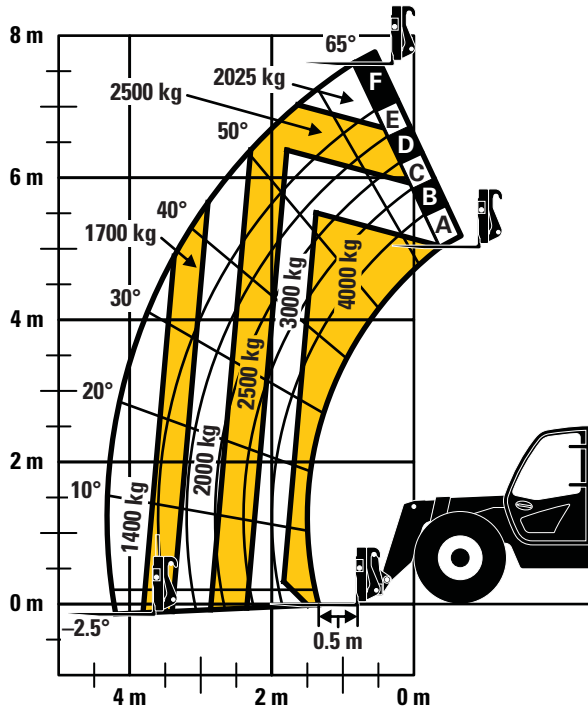

TH3510D Ag Handler

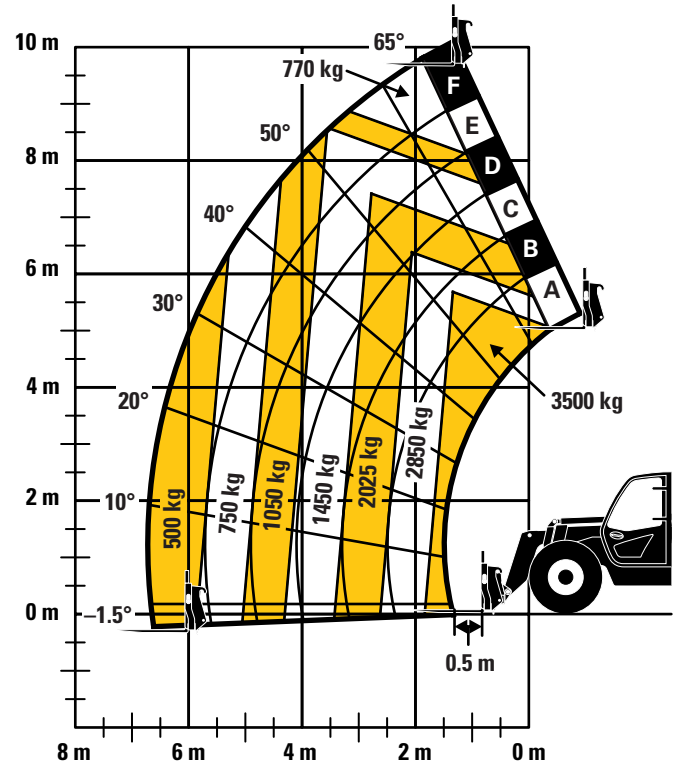

IMPORTANT

Rated lift capacities shown are with machine equipped with carriage and pallet forks. The machine must be level on a firm surface with undamaged, properly inflated tires. Machine specifications and stability are based on rated lift capacities at specific boom angles and boom lengths. (If specifications are critical, the proposed application should be discussed with your dealer.)

DO NOT exceed rated lift capacity loads, as unstable and dangerous machine conditions will result.

DO NOT tip the machine forward to determine the allowable load.

Use only approved attachments with proper material handler model/attachment load capacity charts displayed in the operator's cab.

Due to continuous product improvements, machine specifications and/or equipment changes may be made without prior notification.

TH357D, TH408D, TH3510D Specifications



Work Tool Attachments



Attachments	Pallet Forks				Lumber Forks		
Size	1219 mm		1524 mm		1524 mm		1830 mm
Weight (per fork)	68 kg	75 kg	93.6 kg	124 kg	111 kg	118 kg	119 kg
Capacity	1720 kg	2485 kg	3100 kg	3700 kg	1633 kg	2450 kg	2563 kg
Hydraulic Supply Requirement	No	No	No	No	No	No	No
Product Description	Adaptable to a range of tasks, including moving and placing palletized loads such as produce crates, lifting bags and moving stable objects. Pallet forks can be used in numerous applications and the varied size and lift capacities provide a range of options.				Designed to lift and transport loose material, lumber forks are intended to pick and place wood or debris, making site maintenance and management simple.		

Attachments	Bale Handler	Manure Fork
Size	1219 mm	2290 mm
Weight (per fork)	552 kg	597 kg
Capacity	1000 kg	1.90 m ³
Hydraulic Supply Requirement	Yes	Yes
Product Description	The hydraulically operated Bale Handler work tool is designed to lift and place single round bales for agricultural work. Utilizing either pressed arms or spikes, the grab can be used on both wrapped and unwrapped bales.	The light duty manure fork and grab is designed for loading and handling loosely-packed manure and silage in farming and agricultural applications. The grab is ideal for grasping manure and bedding materials and provides superior load penetration and reduced spillage.

TH357D, TH408D, TH3510D Specifications

Work Tool Attachments

Attachments	General Purpose Bucket			Light Material Bucket			
							
Size	1 m ³	1.33 m ³	1.5 m ³	1.5 m ³	2 m ³	2.5 m ³	3 m ³
Weight	457 kg	500 kg	868 kg	550 kg	500 kg	526 kg	599 kg
Width	2413 mm	2438 mm	2590 mm	1061 mm	1067 mm	1219 mm	1321 mm
Hydraulic Supply Requirement	No	No	No	No	No	No	No
Product Description	The general purpose bucket is designed for a range of loading and lifting applications, able to hold different density and types of material such as sand, light rock, earth, mulch and mulch.			Light material buckets are the largest volume capacity buckets available for Cat Telehandlers, designed for loading light and loose materials such as grain, hay, mulch and fertilizer.			



Attachments	Grapple Bucket	Material Handling Bucket
		
Size	1.3 m ³	1.49 m ³
Weight	1025 kg	480 kg
Width	2438 mm	2413 mm
Hydraulic Supply Requirement	Yes	No
Product Description	Providing a solution to clamping loose material within a bucket and grasping bulky, irregular shaped objects, the grapple bucket is critical to a range of farm applications.	Used mainly as a bulk loading and dumping bucket, the material handling bucket can handle general site clean up, back filling and carrying tasks.





TH357D, TH408D, TH3510D Specifications

Full List of Attachments

- Pallet Forks
- Lumber Forks
- Block Forks
- Manure Forks
- General Purpose Bucket
- Light Material Bucket
- Grapple Bucket
- Material Handling Bucket
- Multi-Purpose Bucket
- Lifting Hooks
- Material Handling Arm
- Truss Boom
- Bale Grab
- Winch
- Auger
- Trash Hopper
- Sweeper

Tire Options

Tire Type	Air	Air
Tire Name	460/70 R24 XMCL	500/70 R24 XMCL
		
Manufacturer	Michelin	Michelin
Description	A radial tire with excellent traction on all surfaces, particularly soft agricultural surfaces. Features good wear and service life.	
TH357D, TH408D, TH3510D Applicable	●	●

Tire Type	Air	Air	Air	Air
Tire Name	400/80 24 Power CL	440/80 24 Power CL	460/70 R24 Bibload	Duraforce
				
Manufacturer	Michelin	Michelin	Michelin	Firestone
Description	A bias ply tire with directional tread and advanced rubber sidewall. Features multiple casing piles and protective thick rubber.		The bibload tire offers outstanding service life and traction on hard surfaces such as concrete and roads. Allows higher speed and reduced wear when roading, with a reinforced side wall and multi-directional tread for enhanced stability.	Non-directional tread pattern and self-cleaning design to tackle difficult terrain. Low profile sidewall for longer lifespan. A larger footprint for excellent stability and traction and even wear.
TH357D, TH408D, TH3510D Applicable	●	●	●	●

TH357D, TH408D, TH3510D Standard and Optional Equipment

Standard and Optional Equipment

Standard and Optional equipment may vary. Consult your Cat dealer for details.

	Standard	Optional		Standard	Optional
Cab ROPS and FOPS			Electrical		
Longitudinal Stability Indicator	✓	—	1 × 12V 1,000 CCA Battery	✓	—
Reversing Camera	—	✓	2 × 12V 815 CCA Batteries	—	✓
Reversing Sensors	—	✓	Block Heater 240 Volt	—	✓
Electronic Multi function display screen	—	✓	Work Lights, 4 × Cab Mounted (2 front, 2 rear) 2 × Boom Mounted	✓	—
Sunscreen	✓	—	Product Link Ready, Version 641	—	✓
Mechanical Suspension Seat with Seat Belt	✓	—	Seven (7) Pin Trailer Service	—	✓
Air Suspension Seat with Seat Belt	—	✓	Reverse Alarm	✓	—
Heated Air Suspension Seat with Seat Belt	—	✓	Rotating Beacon	—	✓
Roof Wiper	✓	—	Other Equipment		
Screen Guard	—	✓	Boom Brushes	✓	—
Roof Guard	—	✓	Ride Control with Boom Float	—	✓
Heater/De-mister	✓	—	Single Auxiliary Service to Boom Head	✓	—
Air Conditioning	—	✓	2 nd Auxiliary Service to Boom Head	—	✓
Engine Speed Set	✓	—	Auxiliary Service to Rear	—	✓
Multi Function Joystick Controller with FNR	✓	—	Rear Hitch Mirror, Flat	—	✓
Column Mounted FNR Lever	—	✓	Rear Hitch Mirror, Convex	—	✓
Front and Rear Windscreen Wipers	✓	—	Tool Box	—	✓
Mechanical Parking Brake	✓	—	Boom Safety Brace	—	✓
SAHR Parking Brake	—	✓			

(continued on next page)

TH357D, TH408D, TH3510D Standard and Optional Equipment

Standard and Optional Equipment (continued)

Standard and Optional equipment may vary. Consult your Cat dealer for details.

	Standard	Optional		Standard	Optional
Tires			Quick Couplers		
Mitas 15.5/80-24 16 ply	✓	—	Manual Cat “IT” Interface	✓	—
Michelin 460/70 R24 XMCL	—	✓	Hydraulic Cat “IT” Interface	—	✓
Michelin 500/70 R24 XMCL	—	✓	• Competitive couplers are available, please consult your Cat dealer for details.		
Michelin 400/80 24 Power CL	—	✓	Work Tools		
Michelin 440/80 24 Power CL	—	✓	Floating Fork Carriage	—	✓
Michelin 460/70 R24 Bibload	—	✓	ISO Class 3 Fixed Fork Carriage	—	✓
Michelin 15.5 R25 XHA	—	✓	Side Shift Carriage	—	✓
Firestone Duraforce	—	✓	1 m ³ General Purpose Bucket	—	✓
13 × 24 Solid Tires	—	✓	1.5 m ³ Rehandling Bucket	—	✓
Tow Hitches			1.0 m ³ Multi Purpose Bucket	—	✓
Retrieval Hitch	—	✓	2.0 m ³ Grain Bucket	—	✓
Hydraulic Pick Up Hitch	—	✓	2.5 m ³ Grain Bucket	—	✓
EEC Manual Hitch	—	✓	3.0 m ³ Grain Bucket	—	✓
EEC Automatic Hitch	—	✓	1225 mm Bale Fork	—	✓
EEC Automatic Hitch with Piton	—	✓	Grapple Bucket	—	✓
Trailer Braking Valve	—	✓	Muck Fork and Grapple	—	✓
			Bale Handler	—	✓
			Sweeper Collector	—	✓

For more complete information on Cat products, dealer services, and industry solutions, visit us on the web at www.cat.com

© 2018 Caterpillar
All rights reserved

Materials and specifications are subject to change without notice. Featured machines in photos may include additional equipment. See your Cat dealer for available options.

CAT, CATERPILLAR, SAFETY.CAT.COM, their respective logos, "Caterpillar Yellow" and the "Power Edge" trade dress, as well as corporate and product identity used herein, are trademarks of Caterpillar and may not be used without permission.

VisionLink is a trademark of Trimble Navigation Limited, registered in the United States and in other countries.

AEHQ7954-02 (02-2018)
Replaces AEHQ7954-01
(EU)



Courtesy of CraneMarket.com