



*Technical Manual*  
**EHC-4**  
HW/FM  
20FT. BOOM



Serial No. \_\_\_\_\_

404240015-1217-A

Mailing Address:  
P.O. Box 580697  
Tulsa, OK 74158

Phone: 1-800-777-2760  
Fax: (918) 269-6688  
<http://www.autocrane.com>

Physical Address:  
4707 N. Mingo Rd.  
Tulsa, OK 74117-5904



At the time of publishing this manual is accurate to the best of our knowledge. Auto Crane reserves the right to change any or all items, components and parts, necessary for any reason. This right does not obligate Auto Crane to immediately update the manual. If in doubt, please call your local Auto Crane distributor for the most up-to-date information.

Auto Crane Company issues a limited warranty with each unit sold. See warranty pages at the end of the manual.



# Table of Contents

---

SECTION		PAGE
<b>1</b>	<b>Safety Tips And Precautions</b> .....	6
<b>2</b>	<b>Introduction</b> .....	7
<b>3</b>	<b>General Specifications</b> .....	9
	3.1 Dimensions .....	9
	3.2 Capacity .....	9
	3.3 Reach .....	9
	3.4 Cable .....	9
	3.5 Chassis And Mounting Requirements .....	9
	3.6 Electrical System Requirements .....	9
	3.7 Rotation .....	9
<b>4</b>	<b>Load Chart</b> .....	10
<b>5</b>	<b>Qualifications And Operating Practices</b> .....	11
	5.1 Operators .....	11
	5.2 Qualifications For Operators .....	11
	5.3 Conduct For Operators .....	12
	5.4 Operating Practices/Handling Of The Load .....	12
	5.5 Operating Near Electrical Power Lines .....	13
	5.6 Preparing The Crane For Operation .....	15
<b>6</b>	<b>8 Function Pendant with ON/OFF</b> .....	17
<b>7</b>	<b>FM Control Transmitter</b> .....	19
<b>8</b>	<b>FM Control Transmitter Diagnostics</b> .....	22
<b>9</b>	<b>FM Control Transmitter Troubleshooting</b> .....	25
<b>10</b>	<b>FM Control Transmitter ID Code Programming</b> .....	28
<b>11</b>	<b>Maintenance</b> .....	31
	11.1 Inspection Requirements .....	31
	11.2 Inspection Classification .....	31
	11.3 Frequent Inspection .....	31
	11.4 Periodic Inspection .....	32
	11.5 Cranes Not In Regular Use .....	33
	11.6 Inspection Records .....	33
	11.7 Testing Requirements .....	33
	11.8 General Repairs and Maintenance .....	34
	11.9 Maintenance Precautions .....	34
	11.10 Adjustments and Repairs .....	34
	11.11 Lubrication .....	35
	11.12 Rope Replacement .....	35
	11.13 Rope Installation and Maintenance .....	35
	11.14 Paint Finish Maintenance .....	36
	11.15 Lubrication and Maintenance Schedule .....	37

---

# Table of Contents

---

SECTION	PAGE
11.16	Lubrication Points ..... 38
11.17	Adjusting Oil Cooled Worm Brake ..... 39
11.18	Brake Adjustment ..... 39
11.19	Rotation Bearing Replacement Guidelines - 2003-4004 ..... 40
<b>12</b>	<b>Crane Mounting And Installation ..... 41</b>
12.1	Stability Chart Installation ..... 42
12.2	Emergency Crane Operation ..... 44
12.3	Grounding Instructions ..... 45
<b>13</b>	<b>General Dimensions ..... 47</b>
<b>14</b>	<b>Decal Layout ..... 48</b>
<b>15</b>	<b>General Assembly HW ..... 50</b>
<b>16</b>	<b>General Assembly FM ..... 52</b>
<b>17</b>	<b>Pedestal Assembly ..... 54</b>
<b>18</b>	<b>Hoist Assembly ..... 58</b>
<b>19</b>	<b>Hoist Actuator ..... 59</b>
<b>20</b>	<b>Boom Assembly ..... 62</b>
<b>21</b>	<b>Traveling Block Assembly ..... 64</b>
<b>22</b>	<b>TWECO with Switch Mount ..... 65</b>
<b>23</b>	<b>Hydraulic Power Unit ..... 66</b>
<b>24</b>	<b>Hydraulic Control Valve ..... 67</b>
<b>25</b>	<b>Relay Panel ..... 69</b>



# 1 Safety Tips and Precautions

---

## DANGER

Indicates a hazardous situation which, if not avoided, will result in death or serious injury.

## WARNING

Indicates a hazardous situation which, if not avoided, could result in death or serious injury.

## CAUTION

Indicates a hazardous situation which, if not avoided, could result in minor or moderate injury.

## NOTICE

Indicates information considered important, but not hazard-related.

---

## WARNING

Federal law (49 cfr part 571) requires that the Final Stage Manufacturer of a vehicle certify that the vehicle complies with all applicable federal regulations. Any modifications performed on the vehicle prior to the final state are also considered intermediate stage manufacturing and must be certified as to compliance. The installer of this crane and body is considered one of the manufacturers of the vehicle. As such a manufacturer, the installer is responsible for compliance with all applicable federal and state regulations, and is required to certify that the vehicle is in compliance.

## WARNING

It is the further responsibility of the installer to comply with the OSHA Truck Crane Stability Requirements as specified by 29 CFR part 1910.180 (C) (1). In applications, where the rotation of the load is hazardous, a tag or restraint line should be used, (ref. OSHA 1910.180(h)(3)(xvi)). To reduce the potential for the load to rotate or rope twist, operate at minimal boom angles and extension.

## WARNING

Do not attempt to lift or drag a load from the side! The boom can fail far below its rated capacity.

## WARNING

Do not weld, modify, or use unauthorized components on any Auto Crane unit! This will void any warranty or liability. Also failure of the crane may result.

## WARNING

Failure to correctly plumb and wire crane can cause inadvertent operation and damage to crane and/or personnel!

## WARNING

Auto Crane Company remote controlled cranes are not designed or intended for use for any applications involving the lifting or moving of personnel. Any such use is considered to be improper and the seller shall not be responsible for any claims arising from such use. This sale is made with the express understanding there is no warranty the goods are fit for the purpose of lifting or moving persons or other improper use. There is no implied warranty or responsibility for such uses.

---



### NOTICE

Keep this manual with the crane at all times.

Auto Crane products are designed to provide many years of safe, trouble-free, dependable service when properly used and maintained.

To assist you in obtaining the best service from your crane and to avoid untimely crane and/or vehicle failure, this manual provides the following operating and service instructions. It is specifically recommended that all operating and service personnel consider this manual as mandatory material for reading and study before operating or servicing Auto Crane products. It is highly recommended crane owners, equipment managers, and supervisors also read this manual.

Auto Crane has incorporated several safety features in the crane for your protection.

For your convenience the overall dimensions of the crane are included on the General Dimension Drawing. Rotation and turning radius are also listed on that drawing.

Remember, the crane adds weight to the vehicle. Adding weight may change the driving and riding characteristics of the vehicle unless the appropriate overload spring(s) are installed on the truck. The payload of the vehicle is reduced by the weight of the crane. The operator should exercise care when loading the vehicle. Distributing the payload on the vehicle evenly will greatly improve the driving and riding characteristics of the vehicle.

Auto Crane Company issues a limited warranty certificate with each unit sold. See last page for warranty.

The cranes are attached to your 12-volt truck electrical system through the vsu provided. The crane is another highly efficient Auto Crane product. The use of a maintenance-free battery is not recommended on any Auto Crane product. The recommended alternator and battery that will give the longest life with the most useful duty cycle is a 60-amp alternator with a 500 cold cranking amp battery. These specifications should be considered minimum.

It has always been Auto Crane Company policy to handle all warranty claims we receive as promptly as possible. If a warranty claim involves discrepant material or workmanship, Auto Crane will take immediate corrective action. It is understandable that Auto Crane Company cannot assume responsibility of liability when it is obvious that our products have been abused, misused, overloaded or otherwise damaged by inexperienced persons trying to operate the equipment without reading the manual.

## 2 Introduction

---

### NOTICE

Auto Crane will not assume responsibility or liability for any modifications or changes made to unit, or installation of component parts without authorization.

Auto Crane maintains a strong distributor network and a knowledgeable Customer Service Department. In most cases, an equipment problem is solved via phone conversation with our customer service department. The customer service department also has the ability to bring a local distributor, a regional sales manager, or a factory serviceman into the solution of an equipment problem.

If, through no fault of Auto Crane Company, it is necessary to send an experienced factory serviceman on a field service call the rates stated in the Auto Crane Distributor's Flat Rate Manual will apply.

Auto Crane Company's extensive Research and Development Program allow our customers to use the best equipment on the market. Our Engineering Staff and our knowledgeable sales people are always available to our customers in solving crane and winch-type application problems. When in doubt, call the Auto Crane factory.

Should you require any assistance not given in this manual, we recommend that you consult your nearest Auto Crane Distributor. Our distributors sell authorized parts and have service departments that can solve almost any needed repair. This manual does not cover all maintenance, operating, or repair instructions pertinent to all possible situations.

If you require additional information, please contact the Auto Crane Company at the following telephone number: **1-800-777-2760**

The information contained in the manual is in effect at the time of this printing. Auto Crane Company reserves the right to update this material without notice or obligation.

## 3.1 DIMENSIONS

- Width: 1 ft. 10 in. (.56 m)
- Height: 2 ft. 3 in. (.69 m)
- Length: 11 ft. 11 in. (3.63 m), stored length.
- Weight: 1,077 lb (488.5 kg)

## 3.2 CAPACITY

- 16,000 ft-lbs (2.2 ton-m)
- Ft-lbs = horizontal distance from center line of rotation to free hanging weight (feet) x amount of weight (pounds).

## 3.3 REACH

- Second boom reach: 10 ft. 4 in. to 16 ft. 4 in.
- Third boom reach: 16 ft. 4 in. to 20 ft. 4 in.

## 3.4 CABLE

- 80 ft. (24.4 m) of 5/16 in. (8 mm) diameter aircraft quality cable. This cable has a single line breaking strength of 9,800 lbs. (4,445 kg).

## 3.5 CHASSIS AND MOUNTING REQUIREMENTS

- 10,500 lbs. (4,763 kg) GVWR minimum.
- 210,600 in-lbs. Resistive Bending Moment (RBM)
- 3/4", Grade 8-UNF Bolts. Tightened to 335 ft. lbs.
- 9" Mounting hole to run electrical lines to the crane from the body.

## 3.6 ELECTRICAL SYSTEM REQUIREMENTS

- Voltage: 12 VDC
- Alternator: 75 amps minimum
- Battery: 130 minute reserve capacity minimum. Maintenance Type battery

## 3.7 ROTATION

- 360° continuous rotation

# 4 Load Chart

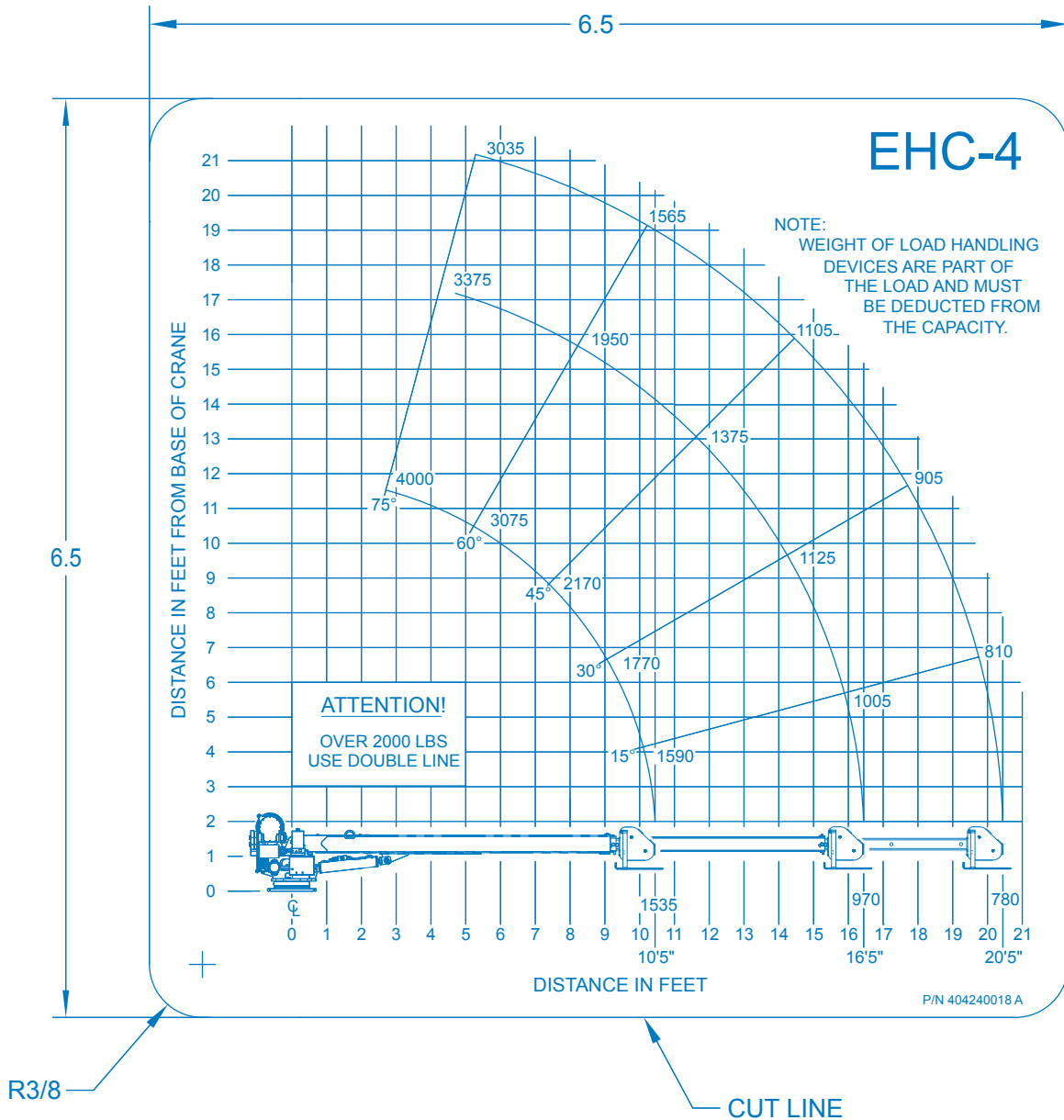

**WARNING**

All load ratings are based on crane capacity, not the vehicle stability. When lifting a heavy load, the weight can create enough tipping moment to overturn the vehicle. **DO NOT USE** the overload shutdown device to determine maximum rated loads, if the crane is equipped with this type of device.

**WARNING**

Always comply with load chart capacities.

# Qualifications and Operating Practices 5

---

THIS IS ONLY AN OVERVIEW OF ALL APPLICABLE QUALIFICATION REQUIREMENTS. REFERENCE ASME B30.5A AND OSHA 1910.180 FOR COMPLETE QUALIFICATION REQUIREMENTS.

## 5.1 OPERATORS

1. Crane operation shall be limited to personnel with the following minimum qualifications:
  - A. Designated persons.
  - B. Trainees under the direct supervision of a designated person.
  - C. Maintenance and test personnel (when it is necessary in the performance of their duties).
  - D. Inspectors (crane).
2. No one other than the personnel specified above shall enter the operating area of a crane with the exception of persons such as oilers, supervisors, and those specified persons authorized by supervisors whose duties require them to do so and then only in the performance of their duties and with the knowledge of the operator or other persons.

## 5.2 QUALIFICATIONS FOR OPERATORS

1. Operators shall be required by the employer to pass a practical operating examination.
2. Qualifications shall be limited to the specific type of equipment for which examined.
3. Operators and operator trainees shall meet the following physical qualifications:
  - A. Vision of at least 20/30 Snellen in one eye and 20/50 in the other, with or without corrective lenses.
  - B. Ability to distinguish colors, regardless of position, if color differentiation is required for operation.
  - C. Adequate hearing with or without hearing aid for the specific operation.
4. Evidence of physical defects or emotional instability, which render a hazard to operator or others, which in the opinion of the examiner could interfere with the operator's performance, may be sufficient cause for disqualification. In such cases, specialized clinical or medical judgment and tests may be required.
5. Evidence that operator is subject to seizures or loss of physical control shall be sufficient reason for disqualification. Specialized medical Tests may be required to determine these conditions.
6. Operators and operator trainees should have normal depth perception, coordination, and no tendencies to dizziness or similar undesirable characteristics.
7. In addition to the above listed requirements, the operator shall:
  - A. Demonstrate the ability to comprehend and interpret all labels, operator's manuals, safety codes, and other information pertinent to correct crane operations.
  - B. Possess the knowledge of emergency procedures and implement it.
  - C. Demonstrate to the employer the ability to operate the specific type of equipment.
  - D. Be familiar with the applicable safety regulations.
  - E. Understand the operating procedures as outlined by the Auto Crane.
  - F. Be thoroughly familiar with the crane and its control functions.

# 5 Qualifications and Operating Practices

---

## 5.3 CONDUCT OF OPERATORS

1. The operator shall not engage in any practice, which will divert his attention while actually operating the crane.
2. Each operator shall be responsible for those operations under the operator's direct control. Whenever there is any doubt as to safety, the operator shall consult with the supervisor before handling the loads.
3. The operator should not leave a suspended load unattended unless specific precautions have been instituted and are in place.
4. If there is a warning sign on the switch or engine starting controls, the operator shall not close the switch or start the engine until the warning sign has been removed by the appointed person.
5. Before closing the switch or starting the engine, the operator shall see that all controls are in the "OFF" or neutral position and all personnel are in the clear.
6. If power fails during operation, the operator shall:
  - A. Move power controls to the "OFF" or neutral position.
  - B. Land the suspended load and boom, if practical.
7. The operator shall be familiar with the equipment and its proper care. If adjustments or repairs are necessary, the operator shall report the same promptly to the appointed person, and shall also notify the next operator.
8. The operator at the start of each shift shall test all controls. If any controls do not operate properly, they shall be adjusted or repaired before operations are begun.
9. Stabilizers shall be visible to the operator while extending or setting unless a signal person assists operator.

## 5.4 OPERATING PRACTICES/HANDLING THE LOAD



### CAUTION

Never use two cranes to support a load too large for either crane.

1. Size of load.
  - A. No crane shall be loaded beyond the rated load except for test purposes
  - B. The load to be lifted is to be within the rated load of the crane and its existing configuration.
  - C. Know the weight of the rigging and deduct from the load rating to prevent overloading the crane.
  - D. When loads that are not accurately known are to be lifted, the person responsible for the job shall determine the weight of the load does not exceed the crane rated load at the radius at which the load is to be lifted.
2. Attaching the load.
  - A. Ensure the load is properly attached to the hook by means of slings or other devices of sufficient capacity.
  - B. Ensure the vehicle is in a level position when loading or unloading.
  - C. Hoist rope shall not be wrapped around the load.
3. The operator shall determine that:
  - A. The crane is level and, where necessary, the vehicle/carrier is blocked properly.
  - B. The load is well secured and balanced in the sling or lifting device before it is lifted more than a few inches.
  - C. Means are provided to hold the vehicle stationary while operating the crane.
  - D. Before starting to lift, the hook shall be positioned over the load in such a manner as to minimize swinging.
4. During lifting care shall be taken that:
  - A. There is no sudden acceleration or deceleration of the moving load.

# Qualifications and Operating Practices 5

- B. When rotating the crane, sudden starts and stops shall be avoided. Rotational speed shall be such that the load does not swing out beyond the radius at which it can be controlled.
  - C. Load, boom or other parts of the crane do not contact any obstruction.
  - D. Cranes shall not be used for dragging loads sideways.
  - E. This standard recognizes that telescopic boom cranes are designed and intended for handling materials. They do not meet personnel lift or elevator requirements. Therefore, no lifting, lowering, swinging or traveling shall be done while a person is on the hook or load. Hook attached suspended work platforms (baskets) shall not be used with cranes covered by this standard.
  - F. The operator should avoid carrying loads over people.
5. When the crane is so equipped, the stabilizers shall be fully extended and set. Blocking under stabilizers shall meet the requirements as follows:
- A. Strong enough to prevent crushing.
  - B. Of such thickness, width and length as to completely support the stabilizer pad.
  - C. Firm footing under all tires, or individual stabilizer pads should be level. Where such a footing is not otherwise supplied, timbers, cribbing, or other structural members to distribute the load so as to not exceed allowable bearing capacity or the underlying material should provide it.
6. In transit, the boom shall be carried in stowed position.
7. The crane shall not be transported with a load on the hook.

## 5.5 OPERATING NEAR ELECTRICAL POWER LINES



**DANGER**

Never operate the crane near electrical lines or in the danger zone area.

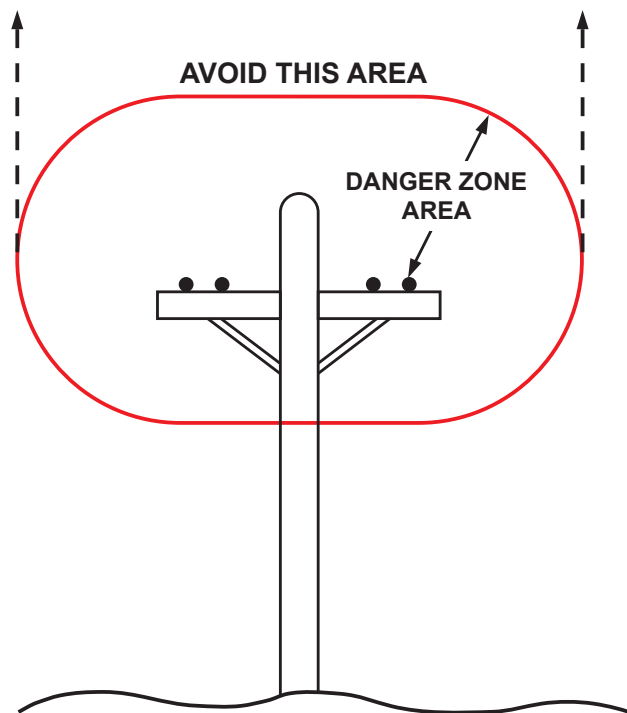

# 5 Qualifications and Operating Practices

1. Do not place any part of the crane or load inside the Danger Zone.

**EXCEPTIONS:**

- A. The Danger Zone may be entered after confirmation by an appointed person the electrical distribution and transmission lines are de-energized and visibly grounded at the point work.
- B. The Danger Zone may be entered if insulating barriers are erected to prevent physical contact with the lines. These can't be a part of or attached to the crane.

2. For the minimum safe distance between electrical lines and any part of the crane or load (including handling appendages), or while in the transit with the boom stowed, see below Table Safe Operating Distance.

3. Exercise caution when working near overhead lines. They can move horizontally and vertically due to wind, shifting the location of the Danger Zone.

4. Assign a qualified, signal person observe the clearance and warn the crane operator before approaching the Safe Operating Distance limits.

- A. Treat all overhead wires as energized until the person or utility owning the line verifies it is not energized.
- B. Exceptions ensuring equivalent protection are allowed, if approved by the administrative or regulatory authority in writing.
- C. Install durable signs at the operator's station and on the outside of the crane, warning that electrocution or serious bodily injury may occur if the Table 1. Safe Operating Distance limits aren't adhered to.

<b>Safe Operating Distance for Cranes Near Electrical Lines</b>		
<b>When operating near high voltage power lines</b>		
Normal Voltage, kV - (phase to phase)	Minimum Required Clearance	
	Ft.	(m)
0 - 50	10	(3.5)
50 - 200	15	(4.6)
200 - 350	20	(6.1)
350 - 500	25	(7.62)
500 - 750	35	(10.67)
750 - 1000	45	(13.72)
<b>When in transit with no load and boom stowed</b>		
0 - 0.75	4	(1.22)
0.75 - 50	6	(1.83)
50 - 345	10	(3.83)
345 - 750	16	(4.87)
750 - 1000	20	(6.1)



# Qualifications and Operating Practices 5

---

## 5.6 PREPARING THE CRANE FOR OPERATION

1. Ensure the manual has been thoroughly read by all crane operating and maintenance personnel and supervisors.
2. Perform a routine inspection of the crane before operation each day. Correct any defects immediately.
3. At the job site, position the vehicle so the crane can reach the load within the rated capacity (center line of rotation to hoist hook).
4. Keep the vehicle as level as possible during operation.

### NOTICE

At a 10° slope, all crane functions are limited to 50% speed. At a 15° slope, all crane functions are disabled.

5. Allow the vehicle engine to warm up before operation.
6. For Auto Crane units using only electric operation:
  - A. Engage the emergency brake.
  - B. Leave the ignition on with the transmission in neutral (or park for automatic transmissions).
  - C. Activate any crane power switches.
7. For Auto Crane units using electric and hydraulic operation:
  - A. Engage the emergency brake.
  - B. Place the transmission in neutral.
  - C. Press the clutch in.
  - D. Activate PTO (Power Take Off).
  - E. Release the clutch.
  - F. Allow sufficient time for the hydraulic fluid to warm up.
  - G. Set the throttle control to the proper engine speed.
8. For all outrigger usage:
  - A. Always extend the outriggers from the vehicle to the ground before crane operation. Ensure they are firmly positioned on solid ground.
  - B. Stand clear of outriggers while being extended.
  - C. If a curb or other object prevents the outrigger from being fully extended, shorten the bearing or fulcrum point and reduce the maximum load accordingly.
  - D. If an outrigger will not reach the ground because of holes or grades, block up the outrigger pad to provide level and firm support to the vehicle.
  - E. If working in soft ground, use wide pads under the outrigger feet to prevent sinking.
  - F. Always store the outriggers before transportation.
    - i. For Auto Crane units with Manual Outriggers:
      1. Pull the lock pins to release the jackleg or drop down outrigger. Move to the outermost lock position.
      2. Ensure lock pins are reinstalled properly.
      3. Lower the Outrigger pad to firm ground and adjust the foot to remove slack.
    - ii. For Auto Crane units with Hydraulic Outriggers:
      1. Shift the diverter valve to the Outrigger position.
      2. Extend the Outriggers to their horizontal limit.
      3. Extend the Outriggers vertically until they make solid contact with the ground with the ground and the truck is approximately level side-to-side.
      4. With the Outriggers properly positioned, return the diverter valve to the Crane position.

## 5 Qualifications and Operating Practices

---

9. Remove the remote control from the cab or storage area. Power the remote control on. Detach the hook from the dead man.
10. The crane is now ready for operation.

### **DURING OPERATION**

1. Always boom up before rotating so the boom will clear the boom support.
2. Always maintain clearance between the boom crown and the traveling block or hook hoist during boom extension. Always observe all relevant safe policies and procedures during crane operation.
4. Always use slow and smooth movements with the crane to avoid causing the load to swing like a pendulum.

### **AFTER OPERATION**

1. After completing the lifting operations, return the boom to the stowed position on the boom support.
2. Replace remote control to its storage location.
3. Return the Outriggers to the stowed position. Ensure they are pinned in place or jack legs are returned to the storage compartment.
4. Always store the crane in its stowed position for transportation.
5. Release the throttle control, press the clutch in, and disengage the PTO. Deactivate any crane power switches.
6. Check vehicle surroundings before moving.
7. Record any unusual occurrence during crane operation which may indicate required maintenance or repair.

# 8 Function Pendant with ON/OFF P/N: 680179000 6

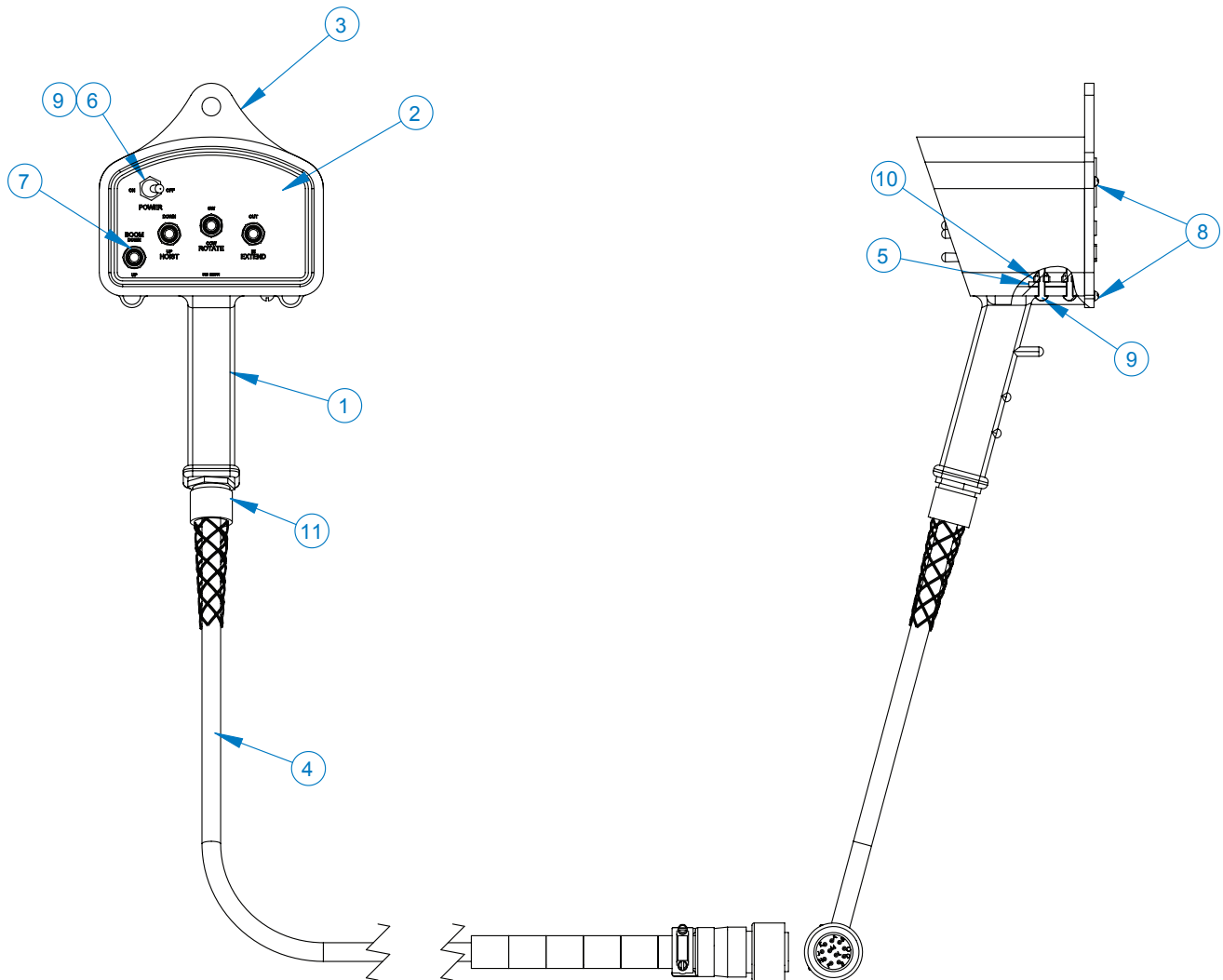

ITEM NO.	QTY	PART NO.	DESCRIPTION
1	1	480501000	PENDANT HOUSING
2	1	366719000	DECAL, PENDANT 8F UNC W/PWR
3	1	480504000	PENDANT BACK PLATE
4	1	680179001	PENDANT CABLE, 11 PIN BAYONET
5	1	480598000	COVER TRIGGER OPENING
6	1	750090000	TOGGLE SWITCH, 1 POLE, 2 POSITION
7	4	634200000	TOGGLE SWITCH KIT
8	4	001004000	SCREW PN HD #6 X 3/4 LG
9	2	002607000	SCREW RD HD #10-24 UNC X 3/4 LG CP
10	2	015801000	NUT HX NYLK #10-24 UNC ZP
11	1	600820000	CORD GRIP, 3/4 NPT, .50-.625" CORD

# 6 8 Function Pendant with ON/OFF P/N: 680179000

## PENDANT WIRING SCHEMATIC

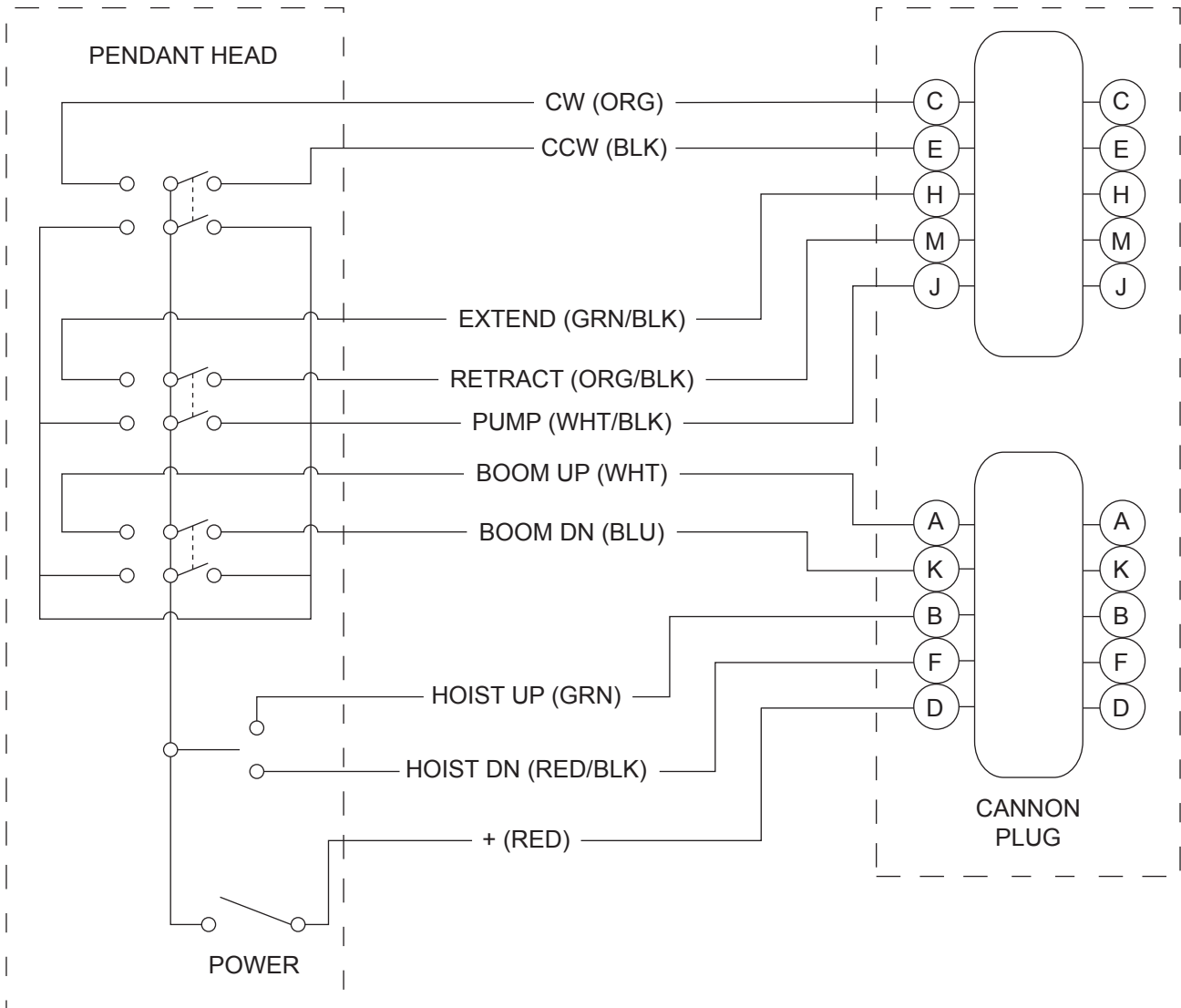

## TRANSMITTER LAYOUT

There is a red light to the left of the ON/OFF Toggle switch and a yellow light to the right. As the battery runs down, the red light will begin to flash as well as the yellow light.

If the yellow light is rapidly flashing this indicates that the unit is transmitting. Refer to the Transmitter Diagnostics Section for a detailed explanation of each light combination.

In addition to the two lights mentioned above there are four function toggle switches. These functions from left to right are to be used to raise and lower the boom, raise and lower the hoist cable, rotate the crane and extend and retract the boom.



## POWER ON/OFF TOGGLE SWITCH

The transmitter is powered by four AA alkaline batteries, located under the back cover of the housing. To turn the transmitter on, press and hold the Power On Toggle, release once the transmit light starts blinking. To turn the unit off, press and hold the power off toggle, release after the transmit light stops flashing.

## FUNCTION SWITCHES

To operate a function, toggle one of the function switches with either the thumb of the hand holding the unit or the thumb or fingers of the opposite hand. More than one function can be activated at one time.

## CARE

Keep dry. Do not clean the transmitter/receiver under high pressure. If water or other liquids get inside the transmitter battery or receiver compartment, immediately dry the unit. Remove the case and let the unit air dry.

## WELDING

Disconnect the radio receiver before welding on the crane, load, or truck. Failure to disconnect will result in the destruction of the radio receiver.

# 7 FM Control Transmitter

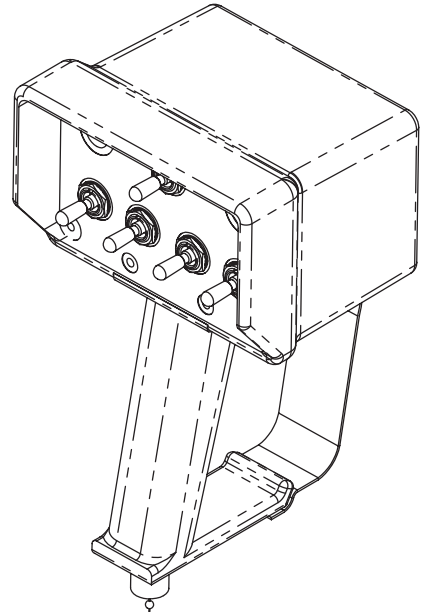
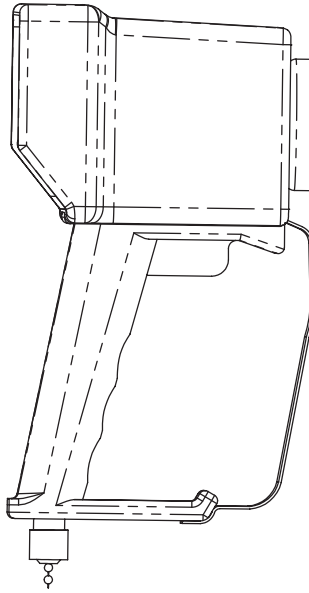
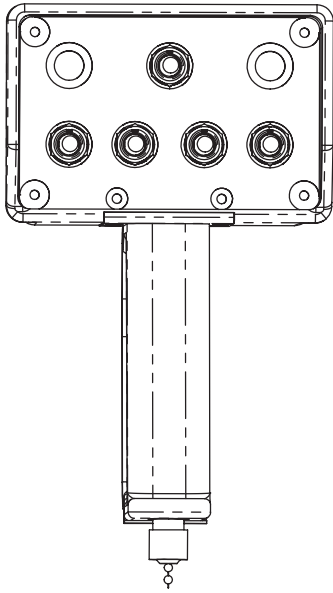



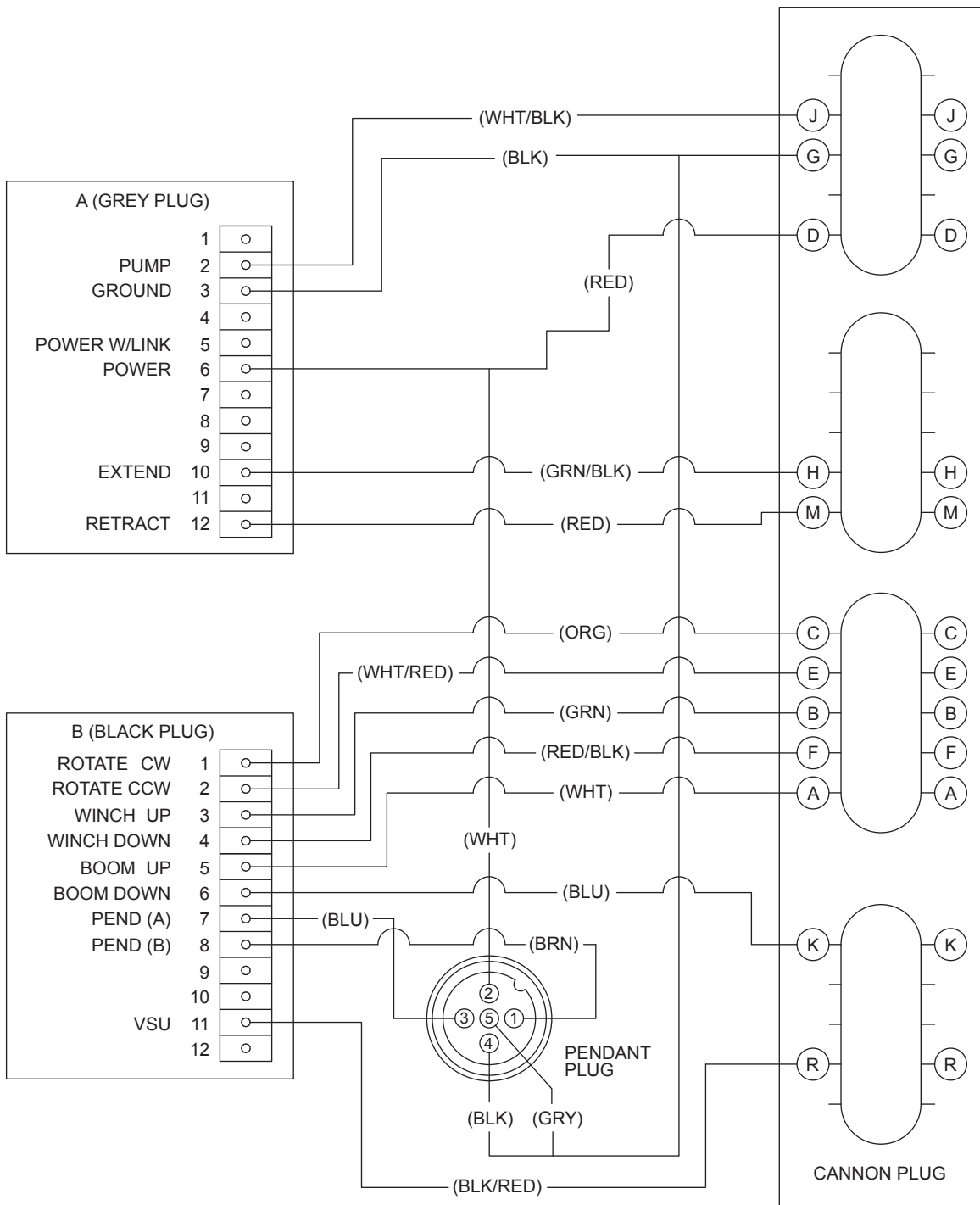

**TOGGLE SWITCH WIRING CHART**

FUNCTION	WIRE COLOR	TERMINAL POSITION
POWER ON	YELLOW	BOTTOM
POWER OFF	GREEN (FROM 8 PIN CONNECTOR)	TOP
BOOM UP	RED	BOTTOM
BOOM DN	ORANGE	TOP
BOOM EXTEND	GREEN (FROM 10 PIN CONNECTOR)	BOTTOM
BOOM RETRACT	BLUE	TOP
ROTATE CW	VIOLET	BOTTOM
ROTATE CCW	GREY	TOP
HOIST UP	WHITE	BOTTOM
HOIST DN	BROWN	TOP
COMMON	BLACK	MIDDLE

## FM CONTROL TRANSMITTER WIRING SCHEMATIC

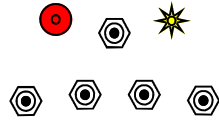
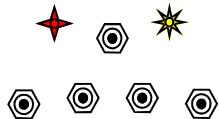
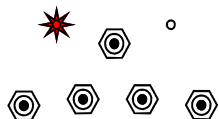

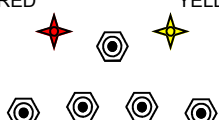
# 8 FM Control Transmitter Diagnostics

<p>RED                      YELLOW</p> 	<p>Tether connection detected</p>
<p>RED                      YELLOW</p> 	<p>Low battery. Unit will run approximately 10 hours after Battery light starts flashing.</p>
<p>RED                      YELLOW</p> 	<p>Flashing rapidly for 10 seconds indicates a transmitter failure.</p>
<p>RED                      YELLOW</p> 	<p><b>Normal Operation</b> The Active light will flash several times per second, indicating that the transmitter is sending signals to the receiver. The Active light will remain on momentarily whenever a function changes.</p>
<p>RED                      YELLOW</p> 	<p><b>Normal Operation</b> The transmitter is in Download Mode.</p>
<p>RED                      YELLOW</p> 	<p>Stuck switch detected. Ensure that all switches are in a centered position. The transmitter will not power up when a function is ON.</p>
<p>RED                      YELLOW</p> 	<p><b>On Power Down</b> Unit is still powered. Check for stuck switches, as the transmitter will not power down when a function is ON. Alternating flash means that the transmitter is in Calibration Mode.</p>

Light Legend						
Solid 	Slow Flash 	Fast Flash 	Red Light 	Green Light 	Yellow Light 	Alternating Red & Green Light 



# FM Control Transmitter Diagnostics 8

## Normal Operation

	<p>Transmitter is OFF If the transmitter is off, the receiver is operating properly.</p>
	<p>Transmitter is ON When the transmitter is turned on, the Link light (fast flashing) and E-Stop (GREEN) indicates the receiver is operating properly.</p>
	<p>Transmitter is in Operation When a function is activated on the transmitter, the Fault light will turn on GREEN. This indicates the receiver is operating properly.</p>
	<p>Transmitter is OFF When a latched function is activated then the transmitter is turned off, the Fault light will stay on GREEN. If the system was intentionally designed this way, the receiver is operating properly, if not call for service.</p>

## Trouble Indicators

**Note:** In some cases, the indicator lights will be different depending on whether the transmitter is on or off. Please note the transmitter status in the "Description" column for each case.

Indicator Lights	Description	Solution
	<p>Transmitter is ON The reason is the transmitter is not communicating with the receiver.</p>	<p>Refer to <b>Trouble Shooting Chart #3</b> for solutions.</p>
	<p>Transmitter is ON A low battery condition has been detected.</p>	<p>To detect intermittent conditions caused by poor or corroded ground or power circuits, the GREEN light will continue to flash for 30 seconds after the condition has been removed.</p>
	<p>Transmitter is ON An internal fault with the E-Stop has been detected.</p>	<p>Check fuse, if OK then: Inspect E-Stop wiring for short circuit. Disconnect E-Stop wire as close to the receiver output as possible. If the Status light changes to: GREEN, a short occurs after disconnection point. Stays flashing RED, send it in for service.</p>
	<p>Transmitter is ON A short to ground or excessive current draw on an output. It is most likely caused by a wiring fault.</p>	<p>Ensure transmitter is functioning properly, check status of each output connection: Press each function button and observe Fault Light. If GREEN, everything is OK. If RED, there is a short in that connection.</p>
	<p>Transmitter is ON E-Stop output is connected with one of the other outputs or one of the outputs is shorted to power</p>	<p>Turn off transmitter, if condition clears follow E-Stop wire and check for connections with other wires. If condition remains one of the outputs is shorted to power. Test all outputs wires for power.</p>
	<p>Transmitter is OFF A wiring short to the battery has been detected.</p>	<p>Refer to <b>Trouble Shooting Chart #1</b> for solutions.</p>

## Light Legend

Solid	Slow Flash	Fast Flash	Red Light	Green Light	Yellow Light	Alternating Red & Green Light
-------	------------	------------	-----------	-------------	--------------	-------------------------------

# 8 FM Control Transmitter Diagnostics

<p>ESTOP FAULT LINK STATUS</p>	<p>Transmitter is OFF The receiver has detected an internal fault.</p>	<p>Refer to <b>Trouble Shooting Chart #1</b> for solutions.</p>
<p>ESTOP FAULT LINK STATUS</p>	<p>Transmitter is ON Blown fuse detected. (not functional with proportional units)</p>	<p>Refer to <b>Page 8</b> for instructions on how to open the receiver case to access fuse. Check wiring for shorts or bare spots. If fuses continue to blow, call for service.</p>
<p>ESTOP FAULT LINK STATUS</p>	<p>A setup failure has occurred.</p>	<p>Either hold the Setup button for 5 seconds to return to Setup mode or cycle power to return to the normal operating mode.</p>
<p>ESTOP FAULT LINK STATUS</p>	<p>Transmitter is OFF The receiver is powered incorrectly.</p>	<p>Most likely cause of this condition is that an output wire or the E-Stop wire has been connected to a power source while the power wire is disconnected from the Power Input (A6). I.E. Receiver is being powered from an output and not Power Input.</p>

Light Legend													
Solid		Slow Flash		Fast Flash		Red Light		Green Light		Yellow Light		Alternating Red & Green Light	

## TEST THE RECEIVER - R160

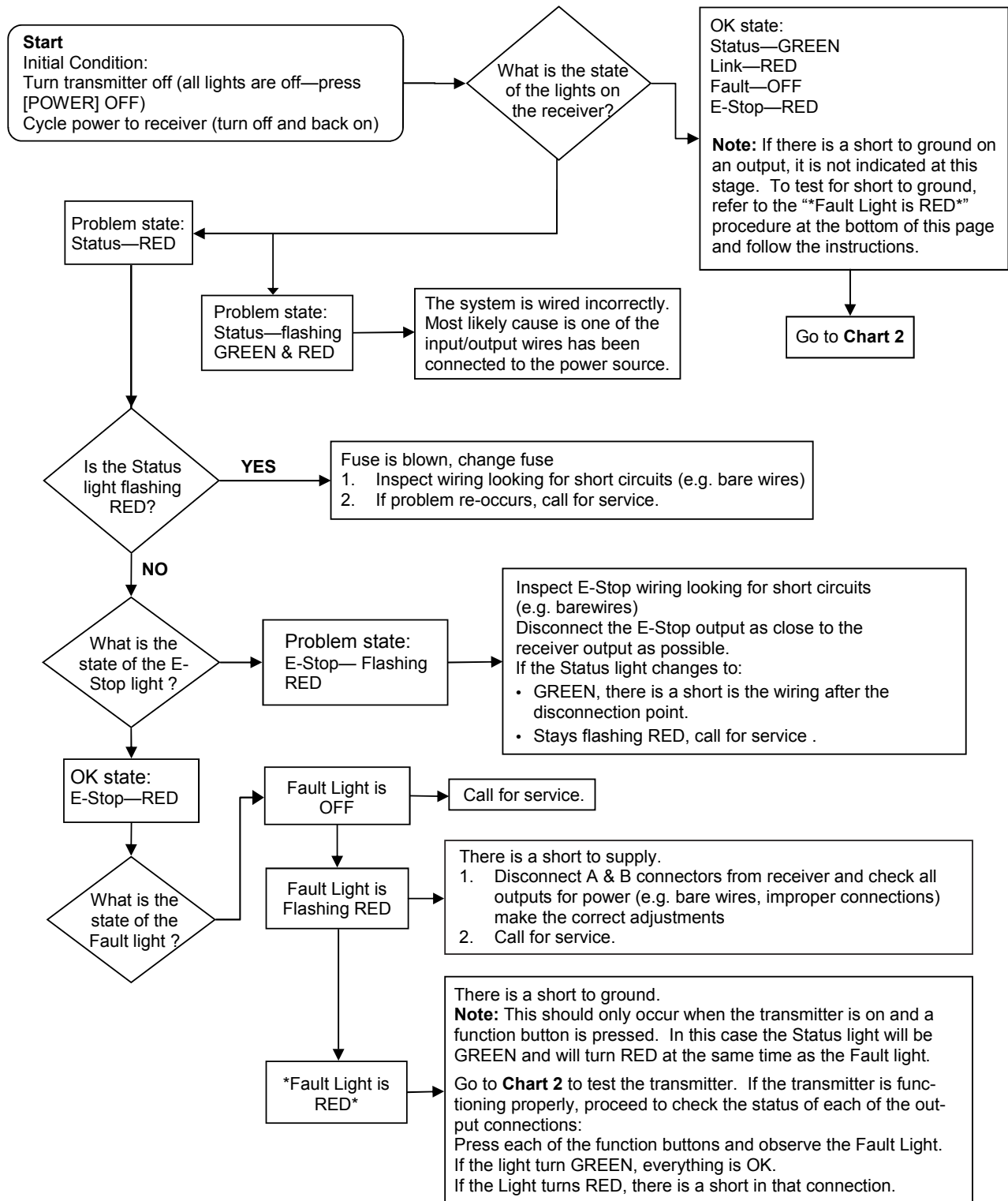

# 9 FM Control Transmitter Troubleshooting

## TEST THE TRANSMITTER - T150

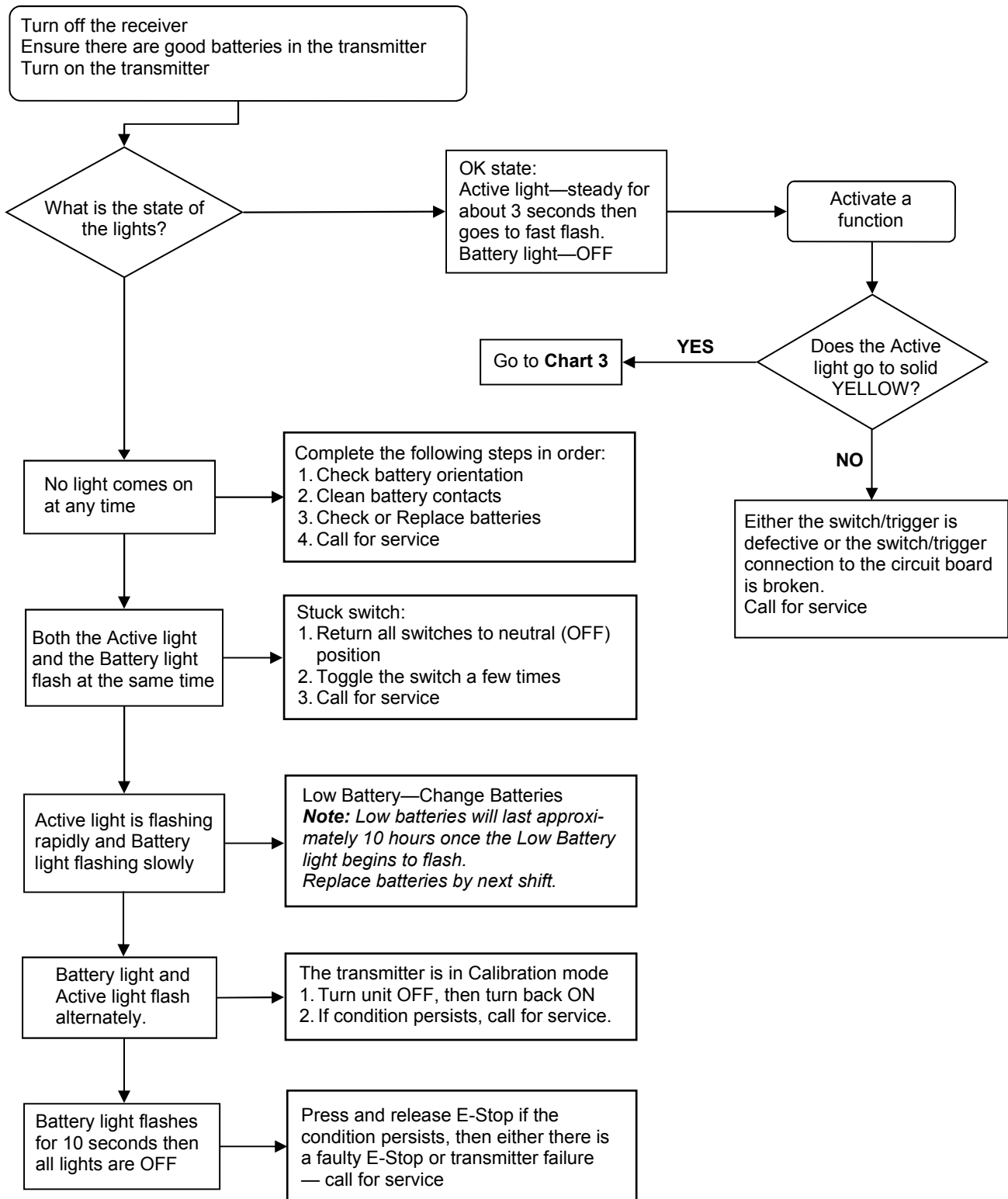

## TESTING THE TRANSMITTER/RECEIVER COMMUNICATION

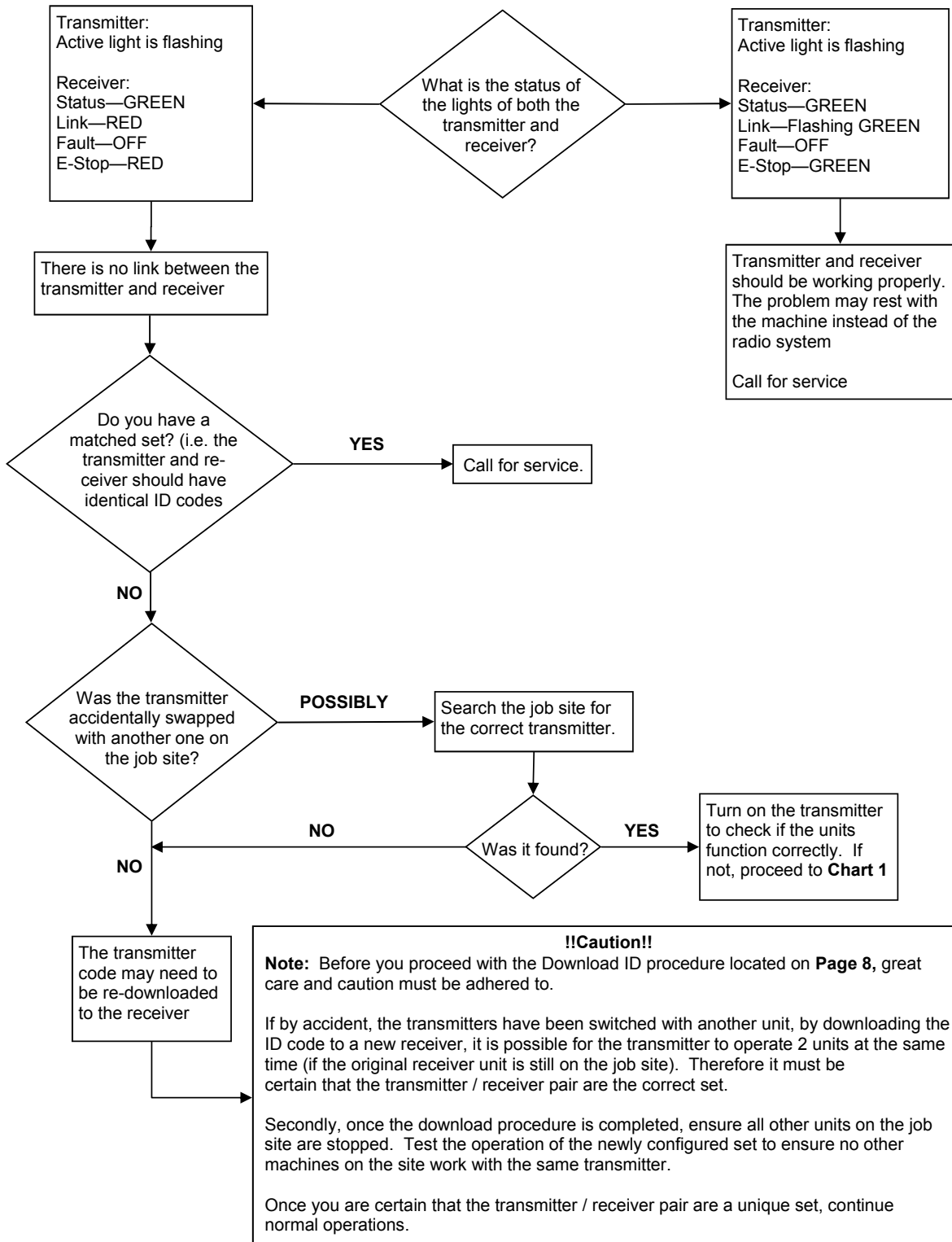

# 10 FM Control Transmitter ID Code Programming

Download ID Code (Use in Case of Link Test Failure)

## CAUTION

Before attempting reprogramming with another transmitter, understand that reprogramming the receiver with another transmitter, could result in two receivers on the job site responding to the one transmitter. If the original transmitter was sent in for repair, disconnect the receiver (disconnect connector A) to continue using the machine without remote capability and without fear of inadvertently operating the machine with the other transmitter.

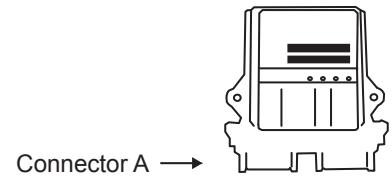

### Reprogramming Tips:

1. Use a pointy instrument to depress the Setup button on the receiver (i.e. a pen) as the button is relatively small
2. Follow each step as laid out in the procedure
3. Never lay the receiver circuit board down on anything metallic (there are contact points on the back which could contact the metal and damage the receiver)

Follow these steps to download the transmitter's unique ID Code into the receiver. This will allow the receiver to establish a radio link with that transmitter. Refer to the Light Legend below for diagram details.

**NOTE:** It is necessary to download the ID Code when replacing either the transmitter or the receiver.

**NOTE:** If the transmitter is connected to the receiver with a tether cable, completing only steps 3 and 5 is necessary (it is not necessary to open the R160 case and press the Setup button).

### 1. Opening the Receiver Case

The cap is held on by two plastic tabs at opposing sides, which can be unlatched as shown using a screwdriver. Once the cap is free, the R160 can slide open. Use a small slotted screwdriver to press the side tabs inward

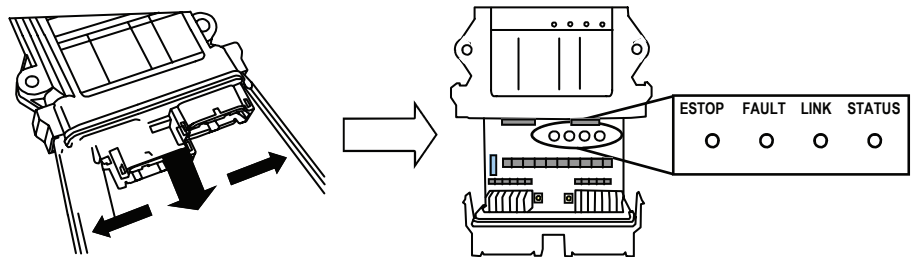

### 2. Prepare Transmitter, Power Receiver

- A. Press [Power] OFF
- B. Supply power to the receiver

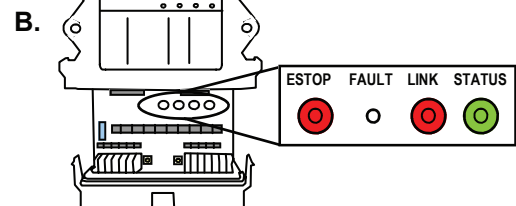
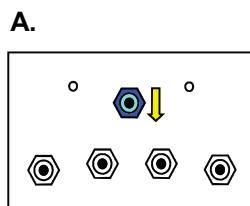

### Light Legend

Solid	Slow Flash	Fast Flash	Red Light	Green Light	Yellow Light	Alternating Red & Green Light
-------	------------	------------	-----------	-------------	--------------	-------------------------------

# FM Control Transmitter ID Code Programming 10

## 3. Power Transmitter into Configuration Mode

- A. Press and hold (BOOM) switch in the UP position.
- B. Press and release [POWER] switch in the OFF position.
- C. Release [BOOM] switch.

The ACTIVE LED will flash once per second

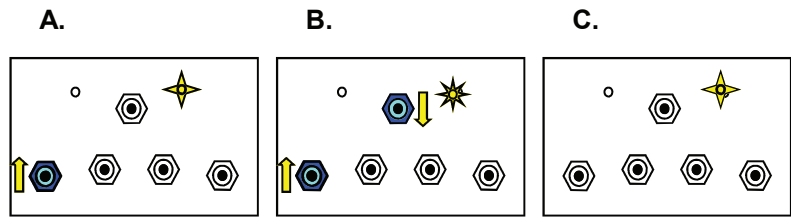

## 4. Put Receiver into Setup

- A. Press and hold [SETUP] button until (STATUS) light goes from slow flash to fast flash.
- B. Release [SETUP] button. (STATUS) light goes to solid GREEN. (LINK) light turns off.

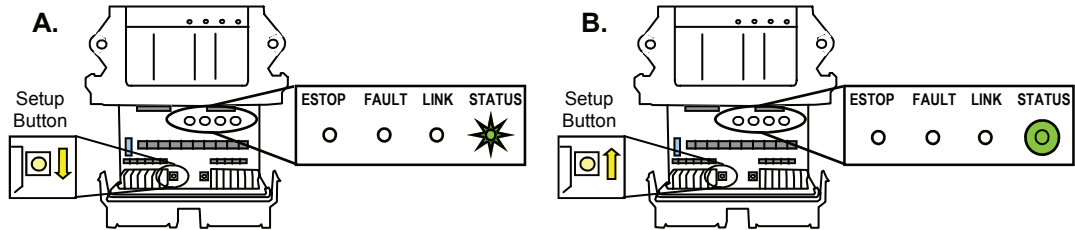



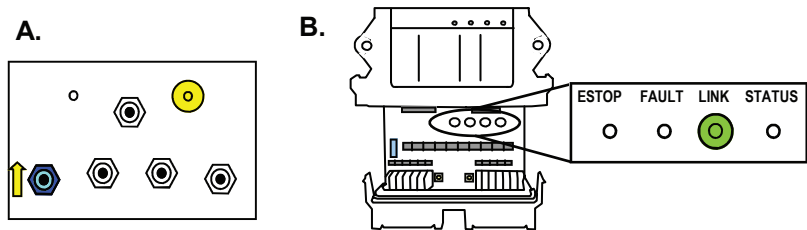

**NOTE:** If left idle in SETUP mode for over 30 seconds, the receiver will time out. The (LINK) light and (STATUS) light will flash RED rapidly. To return to SETUP mode, repeat step 4.

## 5. Download ID Code

- A. Press and release [BOOM] switch in the UP position.
- B. The R160 (LINK) light goes to GREEN. Once complete, (LINK) light goes to red as the transmitter turns off.



Light Legend						
Solid 	Slow Flash 	Fast Flash 	Red Light 	Green Light 	Yellow Light 	Alternating Red & Green Light 





## 11.1 INSPECTION REQUIREMENTS

### NOTICE

Reference ASME B30.5a and OSHA 1910.180 for complete inspection requirements.



### WARNING

All inspections shall be performed by the designated personnel only.

## 11.2 INSPECTION CLASSIFICATION

1. Initial Inspection
  - A. Prior to initial use, all new, altered, modified, or extensively repaired cranes shall be inspected by a designated person to ensure compliance with provisions of this standard.
2. Regular Inspection
  - A. Inspection procedures for cranes in regular service are divided into two general classifications based upon the intervals at which the inspection should be performed. The intervals in turn are dependent upon the nature of the components of the crane and the degree of their exposure to wear, deterioration, or malfunction. The two general classification are herein designated as "frequent" and "periodic" with respective intervals as defined below:
    - i. Frequent Inspection – daily or before each use
    - ii. Periodic Inspection – one to twelve-month intervals or as specifically recommended by the manufacturer or qualified person.

## 11.3 FREQUENT INSPECTION

Inspections should also occur during operation for any deficiencies that might appear between regular inspections. Any deficiencies, such as those listed below, shall be carefully examined and a determination made as to whether they constitute a hazard:

1. Inspect control mechanisms for maladjustment that interferes with proper operation.
2. Inspect control mechanisms for excessive wear of components and contamination by lubricants or other foreign matter.
3. Inspect safety devices for malfunction.
4. Visually inspect all hydraulic hoses, particularly those that flex in normal operation of crane functions.
5. Inspect hooks and latches for deformation, chemical damage, cracks, and wear.
6. Inspect for proper rope reeving.
7. Inspect electrical wiring and components for malfunctioning, signs of excessive deterioration, dirt and moisture accumulation.
8. Inspect hydraulic system for proper oil level and leaks.
9. Inspect tires for recommended inflation pressure, cuts, and loose wheel nuts.
10. Inspect connecting pins and locking device for wear damage and loose retaining bolts.
11. Inspect rope for gross damage, such as listed below, which may be an immediate hazard.
  - A. Distortion such as kinking, crushing, un-stranding, bird-caging, main strand displacement, or core protrusion. Loss of rope diameter in a short length or unevenness of outer strands should be replaced.

# 11 Maintenance

---

- B. General corrosion.
- C. Broken or cut strands.
- D. Use care when inspecting sections of rapid deterioration around flange points crossover points, and repetitive pickup points on drums.
- E. Inspect number, distribution, and type of visible broken wires.

## NOTICE

Continued use of rope depends upon good judgment by a designated person in evaluating remaining strength in a used rope after allowance for deterioration disclosed by inspection. Continued rope operation depends upon this remaining strength.

### 11.4 PERIODIC INSPECTION

Any deficiencies, such as those listed below, shall be carefully examined and determination made as to whether they constitute a hazard:

1. Inspect for deformed, cracked or corroded members in the crane structure and entire boom.
2. Inspect for loose bolts, particularly mounting bolts.
3. Inspect for cracked or worn sheaves and drums.
4. Inspect for worn, cracked, or distorted parts such as pins, bearings, shafts, gears, rollers and devices.
5. Inspect for excessive wear on brakes and clutch system parts and linings.
6. Inspect crane hooks for cracks.
7. Inspect travel steering, braking, and locking devices for malfunction.
8. Inspect for excessively worn or damaged tires.
9. Inspect hydraulic hose, fittings, and tubing for the following problems:
  - A. Evidence of leakage at the surface of the flexible hose or its junctions with the metal and coupling.
  - B. Blistering, or abnormal deformation to the outer covering of the hydraulic or pneumatic hose.
  - C. Leakage at threaded or clamped joints that cannot be eliminated by normal tightening or recommended procedures.
  - D. Evidence of excessive abrasion or scrubbing on the outer surface of a hose, rigid tube, or fitting. Means shall be taken to eliminate the interference of elements in contact or otherwise protect the components.
10. Inspect hydraulic pumps and motors for the following problems:
  - A. Loose bolts and fasteners.
  - B. Leaks at joints between sections.
  - C. Shaft seal leaks.
  - D. Unusual noises or vibrations.
  - E. Loss of operating speed.
  - F. Excessive heating of fluid.
  - G. Loss of pressure.
11. Inspect hydraulic valves for the following:
  - A. Cracks in valve housing.
  - B. Improper return of spool to neutral position.
  - C. Leaks at spools or joints.
  - D. Sticking spools.
  - E. Failure of relief valves to attain or maintain correct pressure setting.
  - F. Relief valve pressure shall be checked as specified by the manufacturers.

12. Inspect hydraulic cylinders for the following problems:
  - A. Driving caused by fluid leaking across piston.
  - B. Rod seals leaking.
  - C. Leaks at welding joints.
  - D. Scored, nicked, or dented cylinder rods.
  - E. Damaged case (barrel).
  - F. Loose or deformed rod eyes or connecting joints.
13. Inspect hydraulic filters for evidence of rubber particles on the filter elements indicating possible hose, O-ring, or other rubber component deterioration. Metal chips or pieces on the filter may denote failure in pumps, motors, or cylinders. Further inspection will be necessary to determine the origin of the problem before corrective action can be taken.
14. Inspect labels to confirm correct location and legibility. Reference decals layout in this manual for proper location of decals.
15. Rope inspections need not be at equal calendar intervals and should be more frequent as the rope approaches the end of useful life. A qualified person shall inspect the wire rope based on such factors as:
  - A. Expected rope life as determined by experience on the particular installation or similar installations.
  - B. Severity of environment.
  - C. Percentage of capacity lifts.
  - D. Frequency rates of operation.
  - E. Exposure to shock loads.
    - i. This inspection shall cover the entire length of the rope. Only the surface wires need to be inspected and no attempt should be made to open the rope. Any deterioration resulting in appreciable loss of original strength shall be noted and determination made as to whether use of the rope would constitute a hazard. A few notable deterioration points are listed below:
      1. Reduction of rope diameter below nominal diameter due to loss of core support.
      2. Internal or external corrosion.
      3. Wear of outside wires.
      4. Severely corroded, cracked, bent, worn, or improperly applied connections.

## 11.5 CRANES NOT IN REGULAR USE

A crane, which has been idle for a period of more than one month or more, shall be given an inspection conforming to the "initial" and "periodic" inspection requirements of this section.

## 11.6 INSPECTION RECORDS

Dated records of periodic inspection should be made on critical items such as brakes, crane hooks, rope, cylinders, and relief pressure valves.

## 11.7 TESTING REQUIREMENTS

### NOTICE

Reference ASME B30.5a and OSHA 1910.180 for complete testing requirements.

# 11 Maintenance

---



## WARNING

All testing shall be performed by designated personnel only. Prior to initial use, all new, altered, modified, or extensively repaired cranes shall be inspected by a designated person to ensure compliance with provisions of this standard.

1. Test all functions to verify speed and operation.
2. Ensure all safety devices are working properly.
3. Confirm operating controls comply with appropriate function labels.
4. Test loads shall not exceed 110% of the manufacturer's load rating.
5. Written reports shall be maintained showing test procedures and confirming the adequacy of repairs.

## 11.8 GENERAL REPAIRS AND MAINTENANCE

### NOTICE

Reference ASME B30.5a and OSHA 1910.180 for complete maintenance and repair requirements.



## WARNING

All repairs and maintenance shall be performed by designated personnel only. Establish a preventative maintenance program based on this section. Obtain all replacement parts from your local authorized distributor.

## 11.9 MAINTENANCE PRECAUTIONS

1. Place crane where it will cause the least interference with other equipment or operations.
2. Verify all controls are in the OFF position and all operating features secured from inadvertent motion by brakes, pawls, or other means.
3. The means for starting the crane shall be rendered inoperative.
4. The boom should be secured in place before maintenance.
5. Relieve hydraulic oil pressure from all hydraulic circuits before loosening or removing hydraulic components.
6. Warning or "OUT OF ORDER" signs shall be placed on all crane controls.
7. After adjustments and repairs have been made, the crane shall not be returned to service until all guards have been reinstalled, trapped air removed from hydraulic system (if required), safety devices reactivated, and maintenance equipment removed.

## 11.10 ADJUSTMENTS AND REPAIRS

1. Any hazardous conditions disclosed by the inspection requirement shall be corrected before operation of crane is resumed.
2. Adjustments shall be maintained to assure correct of functioning of components, the following are examples:
  - A. Function operating mechanism.
  - B. Safety devices.
  - C. Control systems.
3. Repairs or replacements shall be provided as needed for operation, the following are examples:
  - A. Critical parts of functional operating mechanisms which are cracked, broken, corroded, bent, or excessively worn.

- B. Critical parts of the crane structure which are cracked, bent, broke, or excessively corroded.
  - C. Crane hooks showing cracks, damage, or corrosion shall be taken out of service. Repairs by welding are recommended.
4. If bleeding the hydraulic system is required, run each crane function until smooth operation of that particular function is noticeable.

## 11.11 LUBRICATION

All moving parts of the crane, for which lubrication is specified, should be regularly lubricated per the manufacturer's recommendations and procedures.

## 11.12 ROPE REPLACEMENT

No precise rules can be given for determination of the exact time for replacement of rope, since many variable factors are involved.

Replacement rope shall have a strength rating at least as great as the original rope furnished or recommended by Auto Crane. A rope manufacturer, Auto Crane, or a qualified person shall specify any deviation from the original size, grade, or construction.

Conditions such as the following shall be reason for questioning continued the rope or increasing the frequency of inspection:

1. In running ropes, six randomly distributed broken wires in one strand in one lay.
2. One outer wire broken at the contact point with the core of the rope structure and protrudes or loops out of the rope structure. Additional inspection of this section is required.
3. Wear of one third of the original diameter of the outside individual wire.
4. Kinking, crushing, bird caging, or any other damage resulting in distortion of the rope structure.
5. Evidence of any heat damage from any cause.
6. Reduction of nominal diameter of more than:
  - A. 1/64" (0.4 mm) – for diameters up to and including 5/16" (8 mm)
  - B. 1/32" (0.8 mm) – for diameters 3/8" (9.5 mm) through and including 1/2" (13 mm)
  - C. 3/64" (1.2 mm) – for diameters 9/16" (14.5 mm) through and including 3/4" (19 mm)
  - D. 1/16" (1.6 mm) – for diameters 7/8" (22 mm) through and including 1-1/8" (29 mm)
  - E. 3/32" (2.4 mm) – for diameters 1-1/4" (32 mm) through and including 1-1/2" (38 mm)
7. In standing ropes, more than two broken wires in one lay in sections beyond end connections or more than one broken wire at an end connection.

## 11.13 ROPE INSTALLATION AND MAINTENANCE

1. Rope should be stored to prevent damage and deterioration.
2. Unreeling or uncoiling of rope shall be done as recommended by the rope manufacturer and with care to avoid kinking or inducing twist.
3. Before cutting a rope, seizing shall be placed on each of the place where the rope is to be cut to prevent unlaying of the strands. On pre-formed rope, one seizing on each side of the cut is required. On non-preformed ropes of 7/8" (22 mm) or smaller, two seizings on each side of the cut are required. For non-preformed rope 1 in. (25 mm) diameter or larger, three seizings on each side of the cut are required.

# 11 Maintenance

---

4. During installation care should be exercised to avoid dragging of the rope in the dirt or around objects that will scrape, nick, crush, or induce sharp bends in it.
5. Rope should be maintained in a well-lubricated condition. It is important that lubricant applied as a part of the maintenance program shall be compatible with the original lubricant and to this end the rope manufacturer should be consulted. Lubricant applied shall be the type that does not hinder visual inspection. Those sections of rope that are located over sheaves or otherwise hidden during inspection and maintenance procedures require special attention when lubricating rope. The object of rope lubrication is to reduce internal friction and to prevent corrosion.
6. When an operating rope shows greater wear or well-defined localized areas than on the remainder of the rope, rope life can be extended in some cases by shifting the wear to different areas of the rope.

## 11.14 PAINT FINISH MAINTENANCE

The paint finish on Auto Crane products can become damaged during normal use when chipped, scratch, exposed to harsh chemicals, cleaned with pressure washers, or similar. During periods when the truck is exposed to salt or other corrosive chemicals, wash Auto Crane products weekly. Inspect the paint finish monthly or when washed. Immediately repair any exposed bare metal or rust. Repair damaged paint on Auto Crane products with the following procedure:

1. Sand the damaged area to bare metal.
2. Use a solvent to clean the sanded area to remove sanding debris and residue.
3. Wipe dry with a clean cloth to remove any remaining debris and residue.
4. Use a primer compatible with Sherwin Williams E2W932 epoxy primer.
5. Prime the sand areas to a minimum 2 mm dry film thickness per the primer manufacturer's instructions.
6. Use a paint compatible with Sherwin Williams E2W932 epoxy primer and Sherwin Williams Genesis polyurethane top coat paint.
7. Apply the top coat paint to a minimum 2 mm dry film thickness within 24 hours of applying the primer.
8. The final primer and top coat should have approx. a 4 mm dry film thickness.

## 11.15 LUBRICATION AND MAINTENANCE SCHEDULE

Service Performed	Instructions	Daily	Weekly	3 Months	6 Months	Yearly
Load Hook	Inspect hook and latch for deformation, cracks, and corrosion.	<b>X</b>				
Cable Drum	Ensure cable is wound evenly on drum.	<b>X</b>				
Hoist/Boom Cable	Check for flattening, kinks, broken strands.	<b>X</b>				
Hyd. Hoses	Visual inspection.	<b>X</b>				
Hyd. Fluid	Check fluid level.	<b>X</b>				
Pin Retaining Bolts	Check torque to 23 ft lbs(Grade 5) 35 ft- lbs (Grade 8) as required.	<b>X</b>				
Mounting Bolts	Check torque to 335 ft-lbs as required.		<b>X</b>			
Rotating Ring Gear	Lube with MobileTac LL or Lubriplate.		<b>X</b>			
Sheave Bearings	Sealed bearing, replace if rough or loose.		<b>X</b>			
All Other Bolts	Check and tighten as required.		<b>X</b>			
Lift Cylinder Bearings	Grease with MobilePlex EP-2 or equivalent at zerk fittings			<b>X</b>		
Rotation Bearing	Grease with MobilePlex EP-2 or equivalent at zerk fittings			<b>X</b>		
Rotation Bearing Bolts	Check torque to 170 ft-lbs (hex head) 180 ft-lbs (socket head) as required			<b>X</b>		
Hydraulic Fluid	Drain, flush, and refill with Mobile DTE 13 oil					<b>X</b>
Boom Slide Pads	Pads greased when replaced.					
Filter, Valve Block	Replace annually or every 200 hours of operation as directed by the dirty filter sensor.					
For additional information, see OSHA 1910.180 and ASME B30.5a.						

# 11 Maintenance

---

## 11.16 LUBRICATION POINTS

1. Use only authorized parts. Any damage or malfunction caused by the use of unauthorized parts is not covered by Warranty or Product Liability.
2. Once a bolt has been tightened to specification then removed, the bolt should be replaced with a new one. Auto Crane Company recommends this crane be serviced per the "Crane Inspection Log" P/N 999978. Fill these logs in at the intervals noted and kept as a permanent record. Additional copies are available from your local distributor.

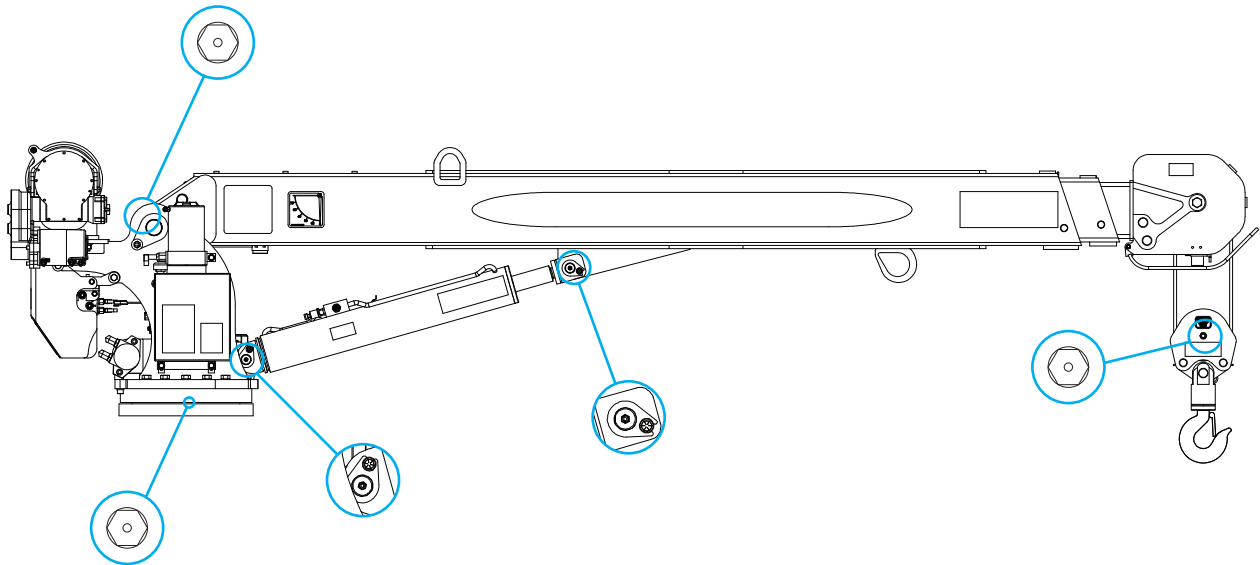



## 11.17 ADJUSTING OIL COOLED WORM BRAKE

The oil-cooled, fully adjustable, automatic safety brake operates in the worm housing lubricant, all part being submerged in oil. When the brake wears to the point that the load begins to drift, the brake can be adjusted as follows:

1. Loosen the lock nut on the adjusting screw.
2. Tighten the brake by turning the adjusting screw clockwise.

### CAUTION

Only ¼ turn is usually required to adjust the brake. Over-tightening can cause overheating, and damage to the brake parts. Tighten the lock nut after adjustment is completed.

If the brake does not respond to adjustment then a new leaf spring and brake disc is needed. A torque wrench can be equipped with a special adapter to fit the input shaft (worm) of the winch. The adapter can be made by welding a nut to the end of a piece of tubing as shown in the following figure.

## 11.18 Brake Adjustment

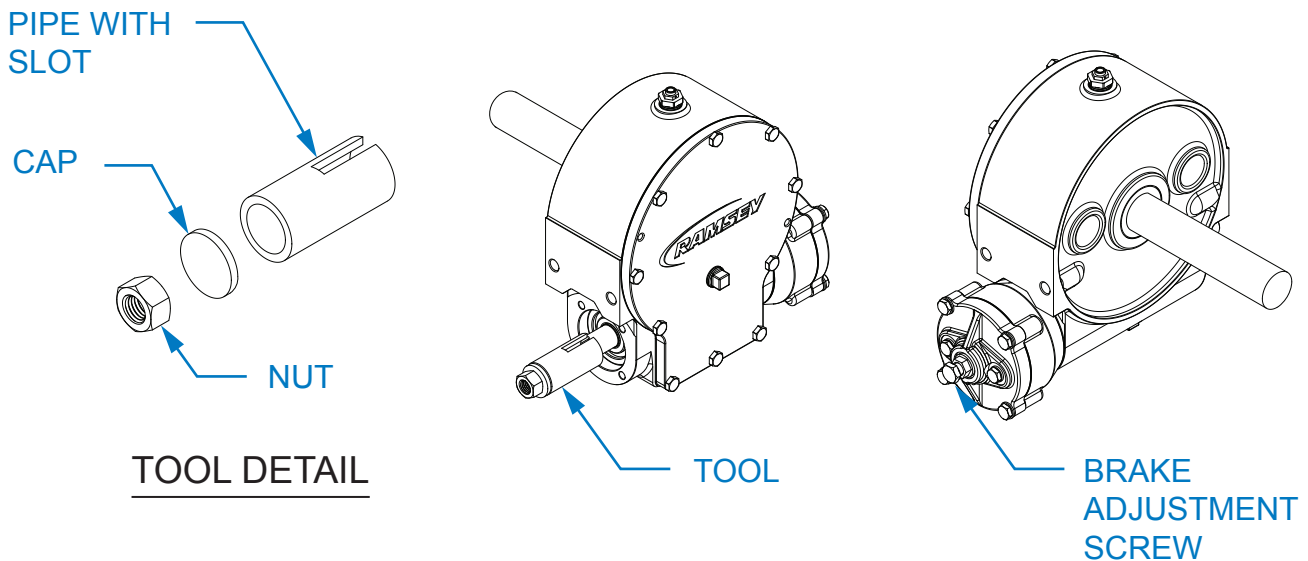

After welding the cap and nut to the tubing, slot the tubing as shown. This will allow the special adapter to slide over the keyway and then act as a large socket. A torque wrench can then be used to apply the proper torque. Turn the torque wrench so that the drum turns in the spool out direction or lowering direction. The torque ratings should be between 8-13 ft-lbs.

If the torque wrench does not show the proper value as it turns, then the worm brake adjusting bolt should be turned clockwise ¼ turn. Each time the adjusting bolt is turned, check the torque reading. Continue this procedure until the proper torque reading is achieved. Then tighten the lock nut.

# 11 Maintenance

---

## 11.19 ROTATION BEARING REPLACEMENT GUIDELINES—2003-4004

All bearings can wear over time. This includes the main rotation bearing on the crane. No precise rules can be given for replacement of the rotation bearing, since many factors are involved. However, there are common symptoms seen during crane operation that may be caused by rotation bearing wear. These symptoms include:

1. Excessive Noise
2. Rough rotation
3. Increased drive power required to rotate.
4. Metal particles in grease

### REASONS FOR ROTATION BEARING REPLACEMENT

1. Any noticeable cracking in the bearing housing
2. Excessive axial play (reference axial play check instructions below)

**⚠ WARNING** Never try to repair a rotation bearing. For a replacement bearing contact your local authorized distributor.

### AXIAL PLAY ALLOWANCE CHECK PROCEDURE

1. Boom up to the max boom angle and measure the clearance between base plate and the rotation bearing with a dial or filler gauge. Reference figure for location.
2. Boom down to the horizontal position and measure the clearance between the base plate and the rotation bearing with a dial indicator or feeler gauge. Reference figure for location.
3. If the difference between the two measurements exceeds 1.5 mm, replace bearing.
4. Rotate crane 45 degrees then repeat steps above until you reach 360 degrees of rotation.

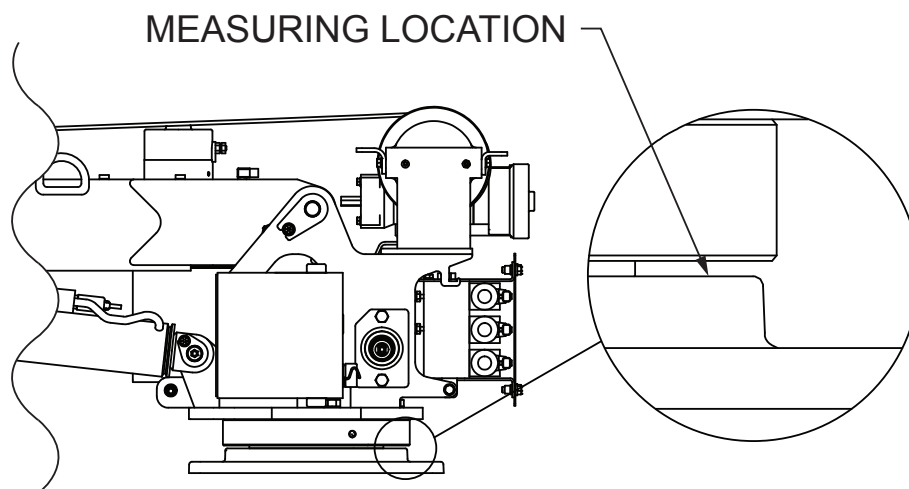

ROTATION BEARING REPLACEMENT KIT P/N: 3208878010

**⚠ WARNING** When replacing rotation bearing, use new hardware which is included in the kit above.

# Crane Mounting and Installation 12

---

For information specific to your crane, such as mounting hole diameter, bolt size and grade, and hydraulic requirements, see General Dimensions.

1. Refer to the Bill of Materials included with your ship kit. Ensure all items listed on the Bill of Materials are included with your crane.

## CAUTION

Failure to use clean hydraulic hoses and components may contaminate the crane and hydraulic system and void warranty.

## NOTICE

Excess flow will cause erratic operation and too little flow will cause poor crane operation.

2. Vehicle shall meet minimum GVWR dependent on crane model:
3. The vehicle must be equipped with an engine speed control and tachometer.
4. Ensure the mounting surface is properly reinforced to withstand the capacity loading of the crane. Ensure the outriggers are used to provide total stability for the truck.
5. Cut the proper sized hole in the mounting location (centered with mounting bolts) for access to hydraulic connections.
6. Ensure the mounting bolts are the proper size and grade. Tighten to the correct specification. See General Dimension.
7. Use a boom support when the crane is not in operation. Connect the traveling block to the hook loop.
8. Electrical hookup:

## WARNING

Failure to correctly plumb and wire crane can cause inadvertent operation and damage to crane and/or personnel.

9. Ensure the Owner's Manual is delivered to the customer.
10. Install voltage switching unit inside compartment safe from weather and contamination.
11. See following page for additional electrical installation.
12. For additional help: Call the Service Department at the Auto Crane Company, 1-800-777-2760, located in Tulsa, OK.

## IMPORTANT!

**FEDERAL LAW (49 CFR PART 571)** REQUIRES THAT THE FINAL STAGE MANUFACTURER OF A VEHICLE CERTIFY THAT HE VEHICLE COMPLIES WITH ALL APPLICABLE FEDERAL REGULATIONS. ANY MODIFICATIONS PERFORMED ON THE VEHICLE PRIOR TO THE FINAL STAGE ARE ALSO CONSIDERED INTERMEDIATE STAGE MANUFACTURING AND MUST BE CERTIFIED AS TO COMPLIANCE. THE INSTALLER OF THIS CRANE AND BODY IS CONSIDERED ONE OF THE MANUFACTURERS OF THE VEHICLE. AS SUCH A MANUFACTURER, THE INSTALLER IS RESPONSIBLE FOR COMPLIANCE WITH ALL APPLICABLE FEDERAL AND STATE REGULATIONS, AND IS REQUIRED TO CERTIFY THAT THE VEHICLE IS IN COMPLIANCE.

IT IS THE FURTHER RESPONSIBILITY OF THE INSTALLER OF THE CRANE TO COMPLY WITH THE OSHA TRUCK CRANE STABILITY REQUIREMENTS AS SPECIFIED BY 29 CFR PART 1910.180 (C) (1).

## 12 Crane Mounting and Installation

### 12.1 STABILITY CHART INSTALLATION

There is a stability chart included in the ship kit. This decal is typically installed on the inside of the door of the crane box. This decal is to alert the user of the available crane capacities around the vehicle.

- 479824002 decal will be installed on an Auto Crane body that was outfitted with an Auto Crane crane and Auto Crane outriggers. Auto Crane has designed the body, crane and outrigger to have stability based on the chart below:

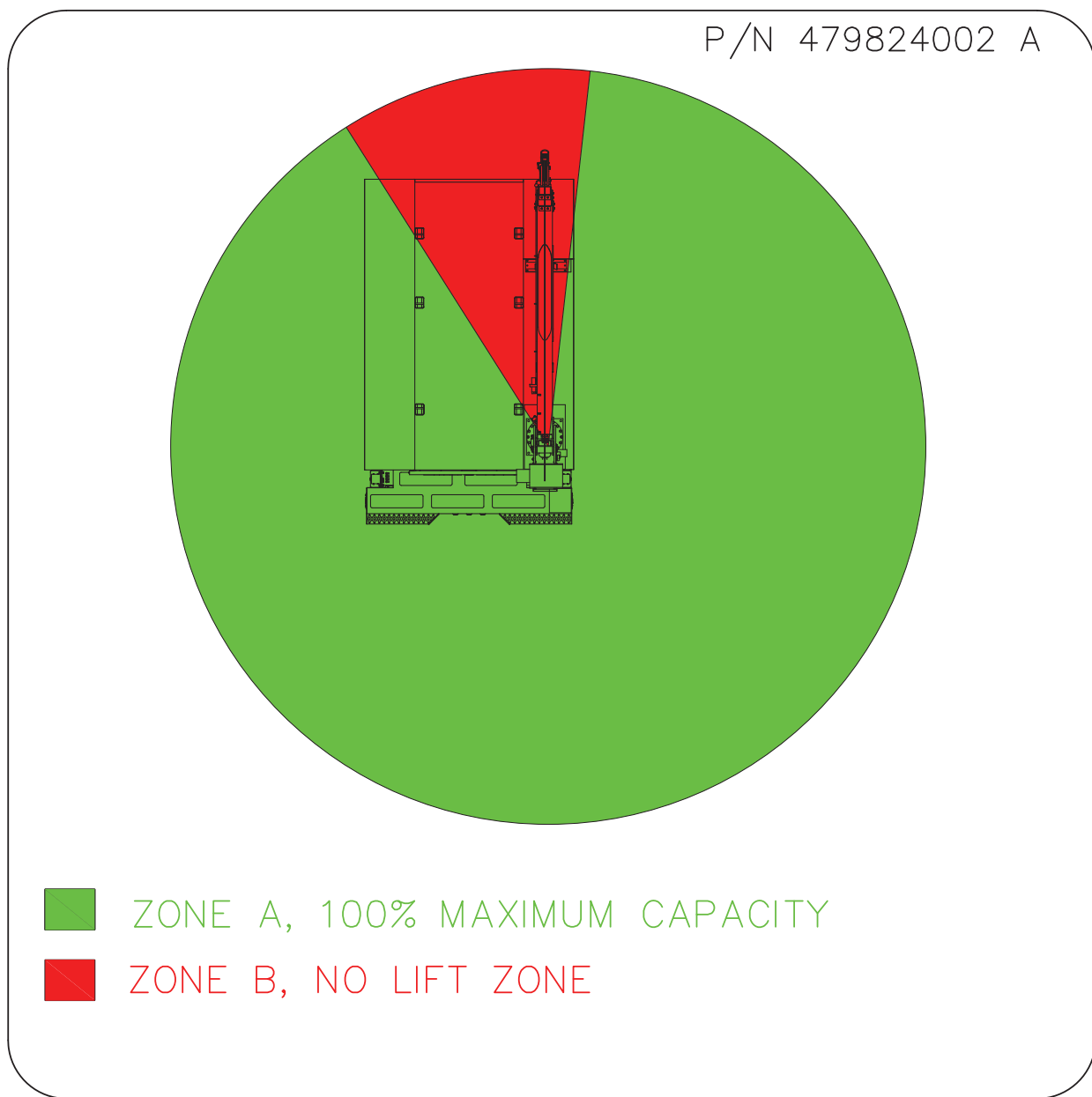

# Crane Mounting and Installation 12

- 479824003 decal will be installed on an Auto Crane body that was not outfitted with an Auto Crane crane and Auto Crane outriggers. Auto Crane has designed the body, crane, and outrigger to have stability based on the chart. The stability chart provides lines to write in the tested stability percentage at each section below:

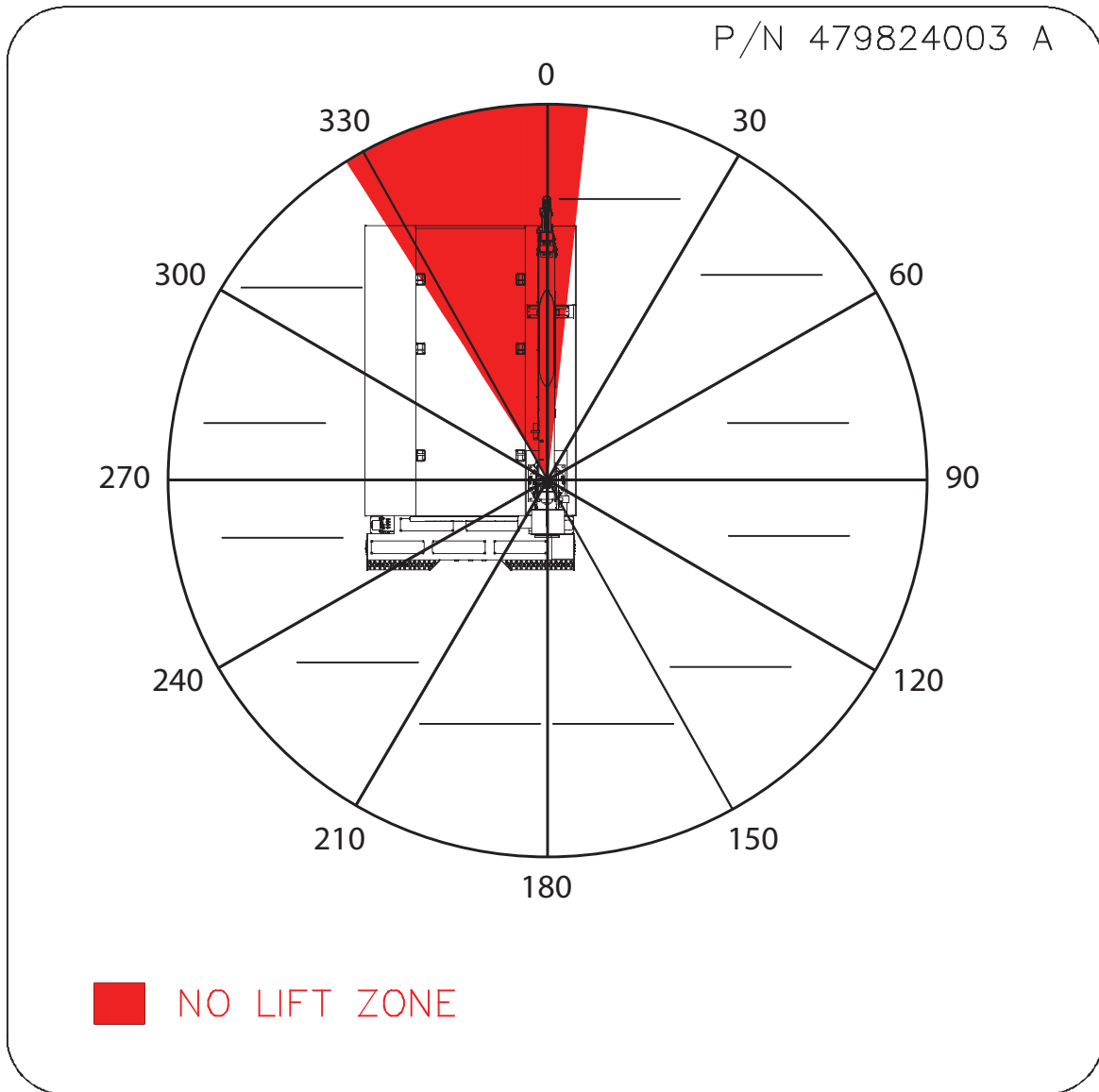

# 12 Crane Mounting and Installation

---

## 12.2 EMERGENCY CRANE OPERATION

If for any reason hydraulic flow or pressure is lost to the crane, use the following procedure to lower the boom until the problem can be fixed.

1. In an emergency situation when it becomes necessary to lower the boom without hydraulic assistance, the counterbalance valve can be used to lower the boom.
2. Ensure the boom will be lowered onto an appropriate support.
3. Loosen the lock nut and slowly turn the Allen head screw clockwise.
4. Count the number of turns and continue to slowly turn the Allen head screw clockwise until the boom just begins to lower.



### CAUTION

Remove any personnel from near the crane as the load is lowering.

5. If the Allen head screw is turned too far, the internal valve will come apart. This condition is not repairable.
6. After the boom is lowered onto the boom support, turn the Allen head screw the same number of turns counterclockwise into the counterbalance valve.
7. After the problem is corrected, readjust the counterbalance valve to ensure proper operation.

## 12.3 GROUNDING INSTRUCTIONS

Attach ground wire to bottom of the crane. Run the ground wire down through the crane box. Locate cable so that it will be protected and avoid sharp edges. Attach ground from crane to chassis frame.

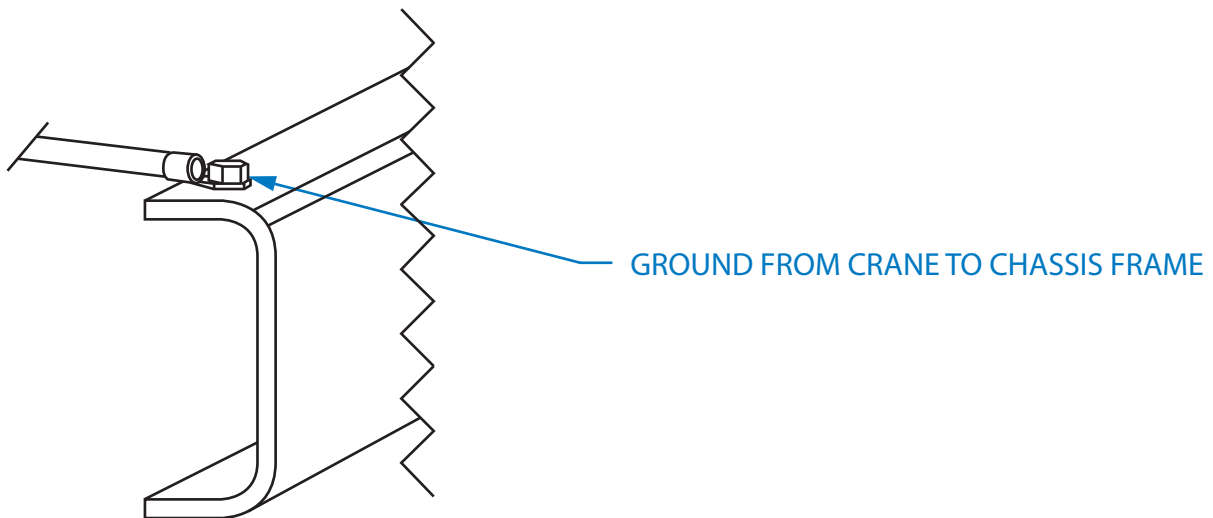
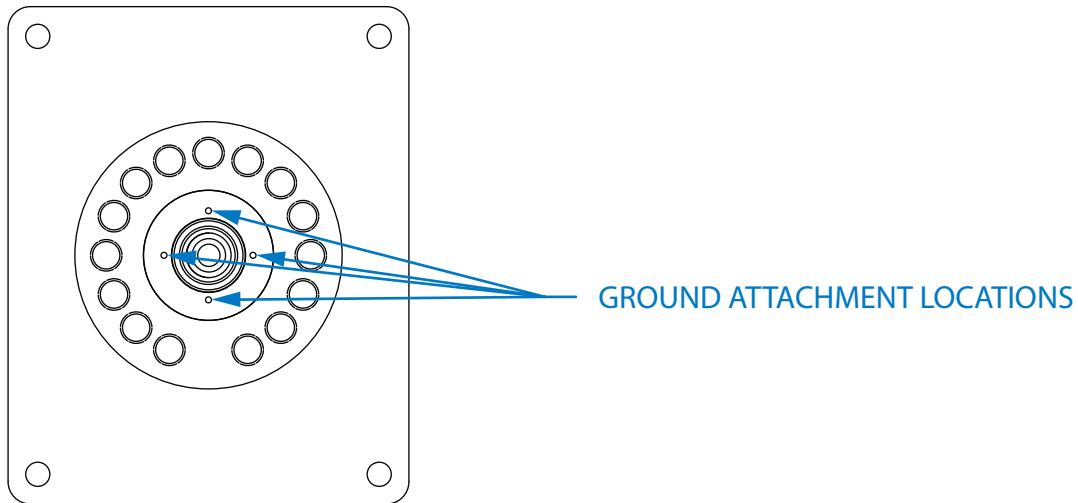





# General Dimensions 13

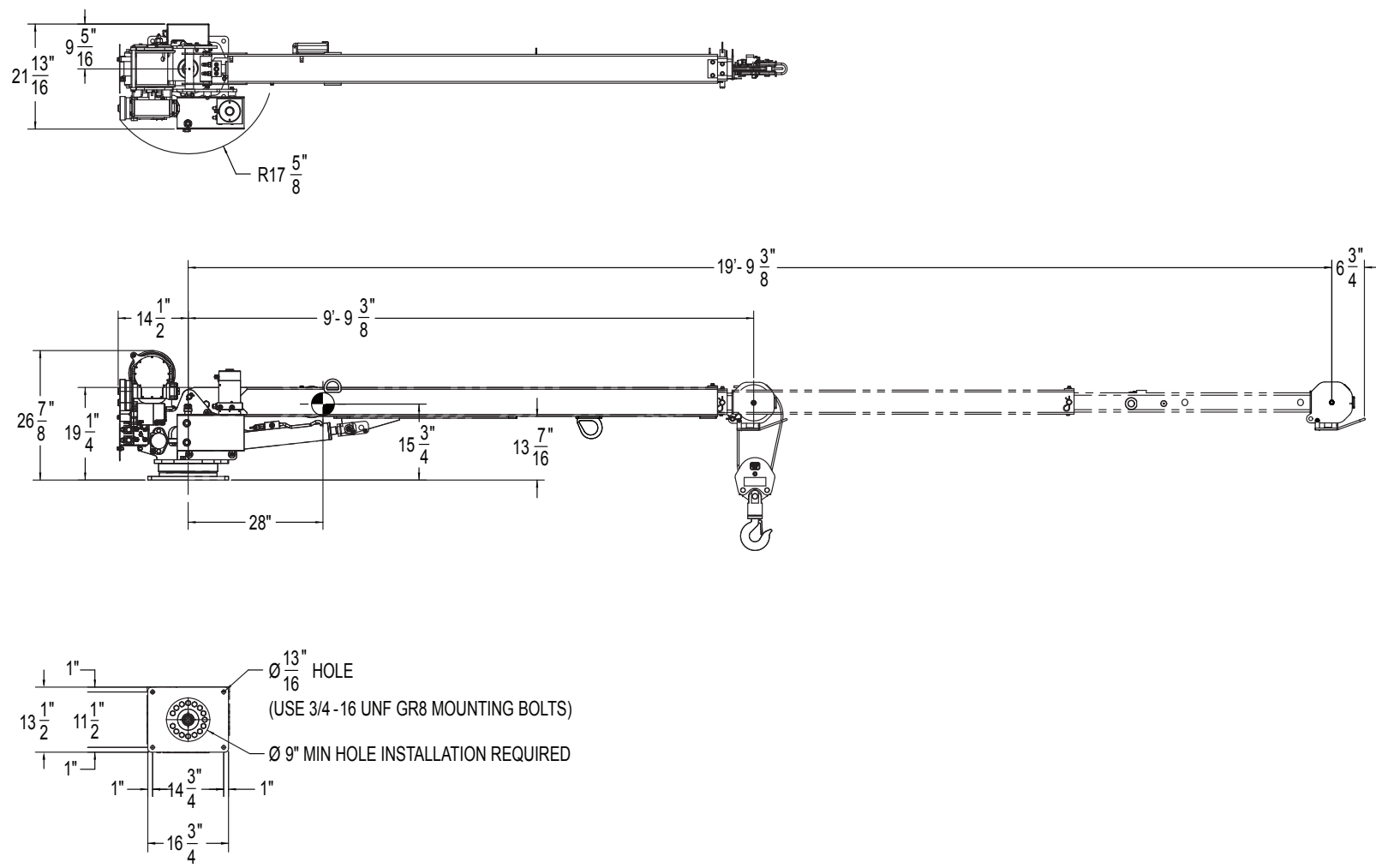

# 14 Decal Layout P/N: 404240009

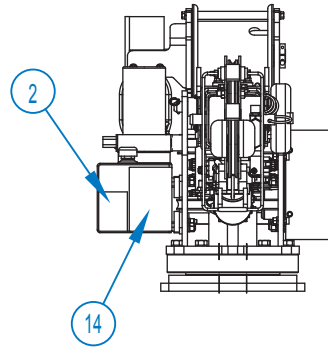
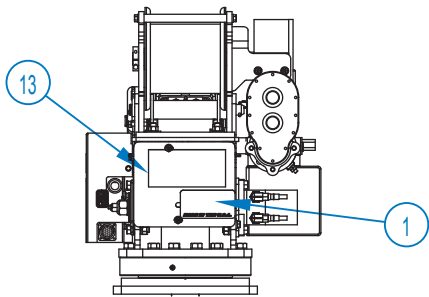
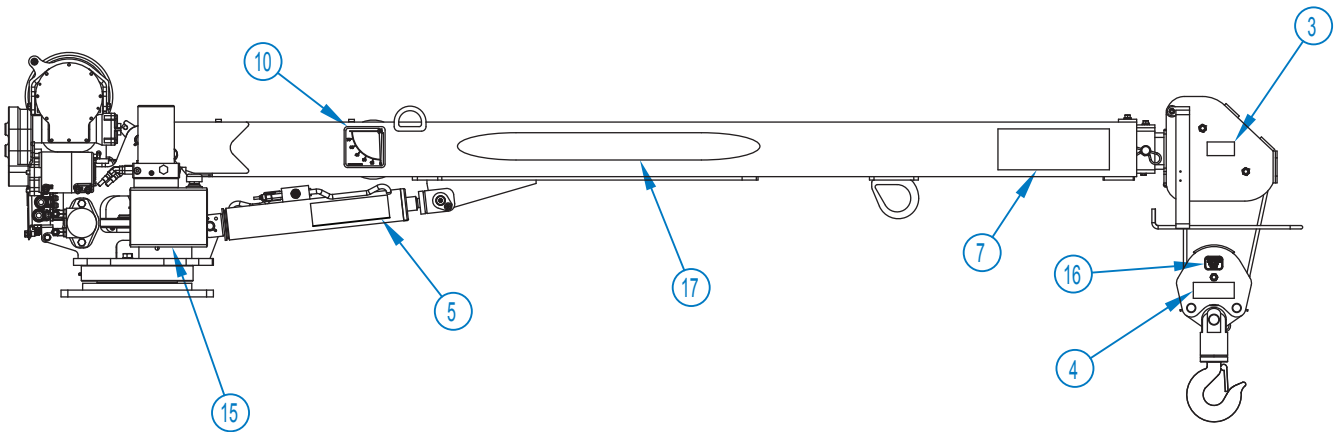
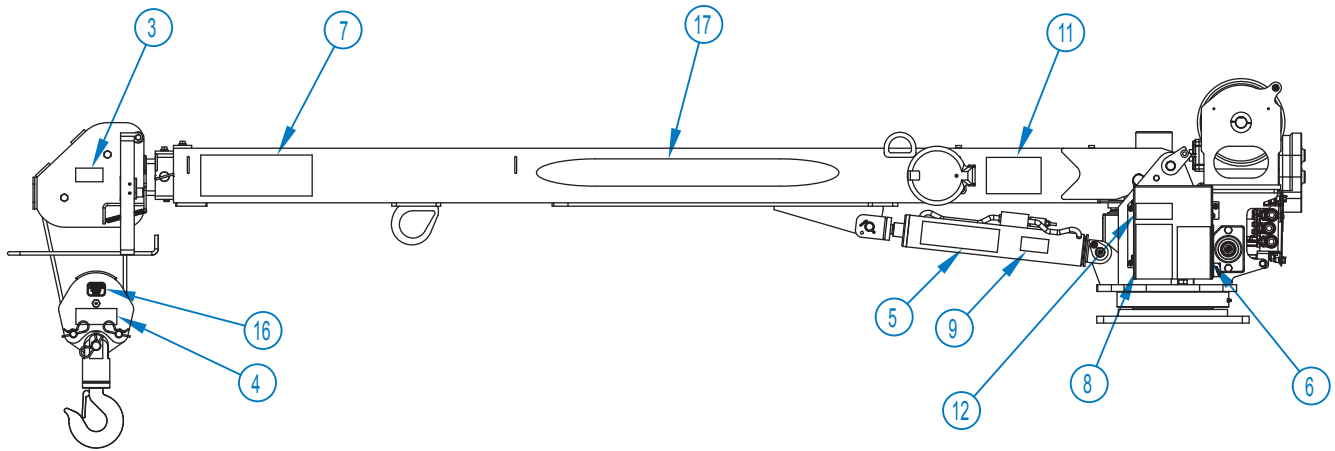

# Decal Layout P/N: 404240009 14

ITEM NO.	QTY	PART NUMBER	DESCRIPTION
1	1	040824000	DECAL, AMERICAN FLAG, MADE IN THE U.S.A.
2	1	040632000	DECAL WARNING - OVERLOAD
3	2	040517000	DECAL STAY CLEAR OF BOOM
4	2	040518000	DECAL STAY CLEAR OF LOAD
5	2	040519000	DECAL DANGER SCISSOR POINT
6	1	040579000	DECAL OPERATION INSTRUCTIONS
7	2	040529000	DECAL DANGER "ELECTROCUTION HAZARD" POWER LINE
8	1	040580000	DECAL TRAINED OPERATOR
9	1	040587000	DECAL WARNING LOAD SENSOR
10	1	320318000	DECAL ANGLE INDICATOR CS
11	1	320318001	DECAL ANGLE INDICATOR SS
12	1	330622000	DECAL SERIAL NO
13	1	360034000	DECAL AUTO CRANE LOGO
14	1	460169000	DECAL WARNING, REMOTE CONTROL
15	1	404240018	LOAD CHART, EHC-4 20FT BOOM
16	2	404212000	DECAL MAX BLOCK LOAD 4004
17	2	600047011	DECAL, AUTO CRANE EHC-4 LOGO, FLATTENED OVAL, 33.25 IN LONG

# 15 General Assembly HW P/N: 404240020

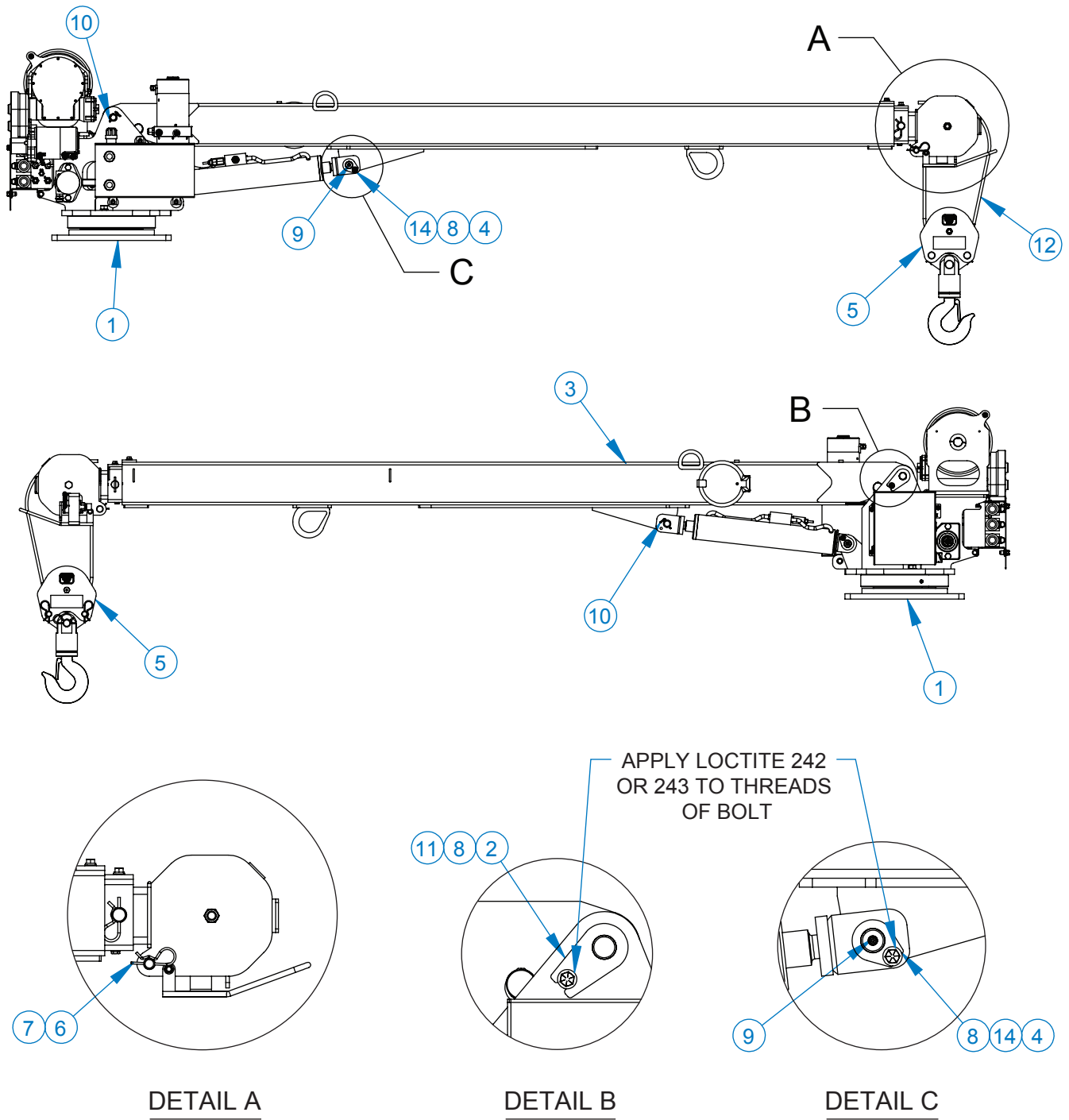

# General Assembly HW P/N: 404240020 15

ITEM NO.	QTY	PART NO.	DESCRIPTION
1	1	404181002	PEDESTAL ASSY, 4004EH
2	1	404220000	PIN WDMT BOOM/PED
3	1	404240100	4004EH BOOM (20FT), SINGLE SHEAVE
4	1	320824000	PIN, LIFT CYLINDER
5	1	404211050	TRAVELING BLOCK ASSY, 4004
6	1	366813000	PIN HITCH
7	1	320434001	PIN, 3/4 X 2-3/4LG
8	2	021200000	WASHER FL 3/8
9	1	239000000	ZERK DRIVE GR
10	2	360678000	PIN, 3/16 COTTERLESS RING
11	1	366159000	SCREW HX HD 3/8-16 UNC X 1-1/2 LG GR8
12	1	360155000	CABLE, GALV 5/16"X7X19X80'-3"
13	1	330372000	NUT HX 3/8 NC GR5
14	1	366158000	SCW HX 3/8 NC X 3/4 GR8
15	1	404240016	SHIP KIT, 4004EH 20FT BOOM, HW
16	1	404240009	DECAL LAYOUT 4004EH (20FT BOOM) FM/HW

# 16 General Assembly FM P/N: 404240030

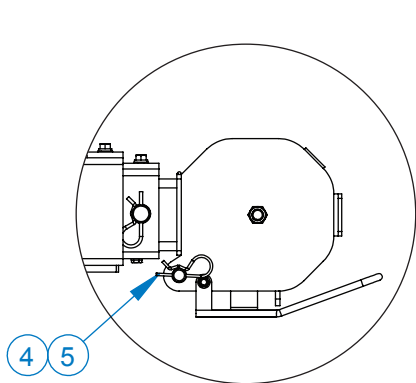
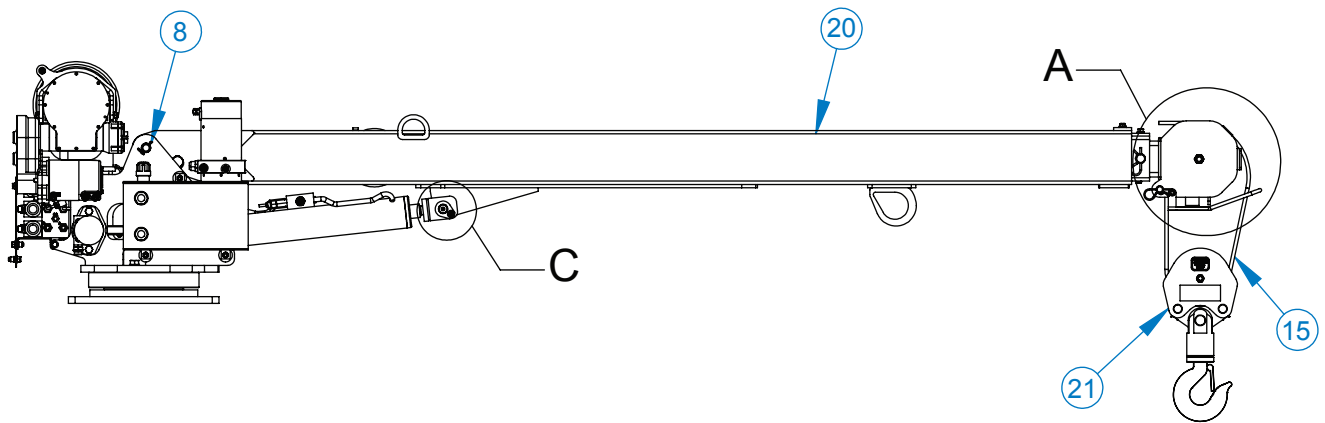
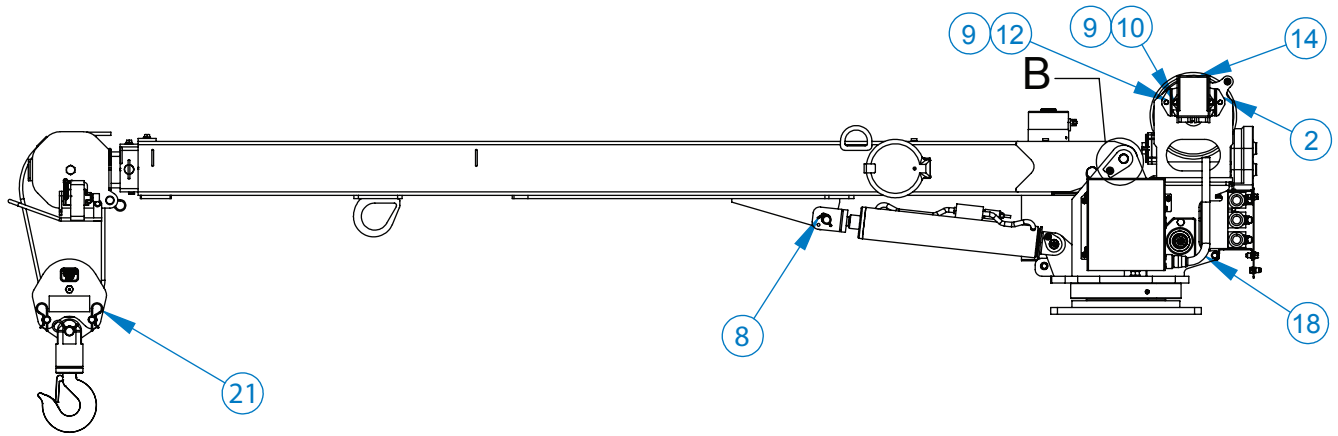

DETAIL A

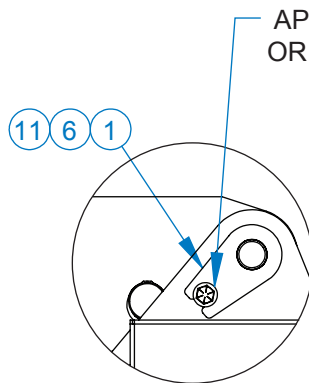

DETAIL B

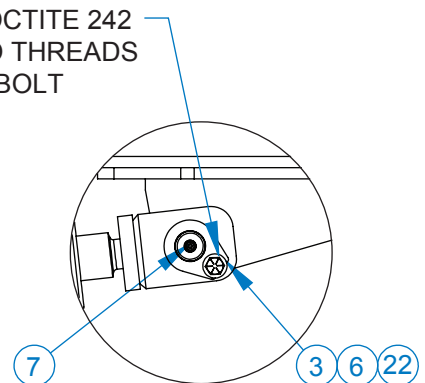

DETAIL C

# General Assembly FM P/N: 404240030 16

ITEM NO.	QTY	PART NO.	DESCRIPTION
1	1	404220000	PIN WDMT BOOM/PED
2	1	366715000	BRACKET ASSEMBLY, RECEIVER MOUNT
3	1	320824000	PIN, LIFT CYLINDER
4	1	366813000	PIN HITCH
5	1	320434001	PIN, 3/4 X 2-3/4LG
6	2	021200000	WASHER FL 3/8
7	1	239300000	ZERK, GREASE
8	2	360678000	PIN, 3/16 COTTERLESS RING
9	4	020200000	WASHER SP LK 1/4
10	2	005500000	SCREW HX HD 1/4-20 UNC X 3/4 LG
11	1	366159000	SCREW HX HD 3/8-16 UNC X 1 1/2 LG GR8
12	2	005901000	SCREW HX HD 1/4-20 UNC X 1/2 LG
13	1	330372000	NUT HX 3/8-16 UNC
14	1	460158000	RECEIVER, NON-PROPORTIONAL
15	1	360155000	CABLE, GALV 5/16" X 7 X 19 X 80'-3"
16	1	404240014	SHIP KIT, EHC-4, 20FT BOOM, FM
17	1	404240009	DECAL LAYOUT 4004EH (20FT BOOM) FM/HW
18	1	680180000	HARNESS, FM, 3203PR(X)
19	1	404181002	PEDESTAL ASSY, 4004EH
20	1	404240100	4004EH BOOM (20FT), SINGLE SHEAVE
21	1	404211050	TRAVELING BLOCK ASSY, 4004
22	1	366158000	SCW HX 3/8 NC X 3/4 GR8
23	1	736274000	NUTSERT 3/8-16 UNC X .027-.15 GRIP
24	1	021100000	WASHER SP LK 3/8
25	1	330371000	SCREW HX HD 3/8-16 UNC X 1 LG GR8

# 17 Pedestal Assembly P/N: 404181002

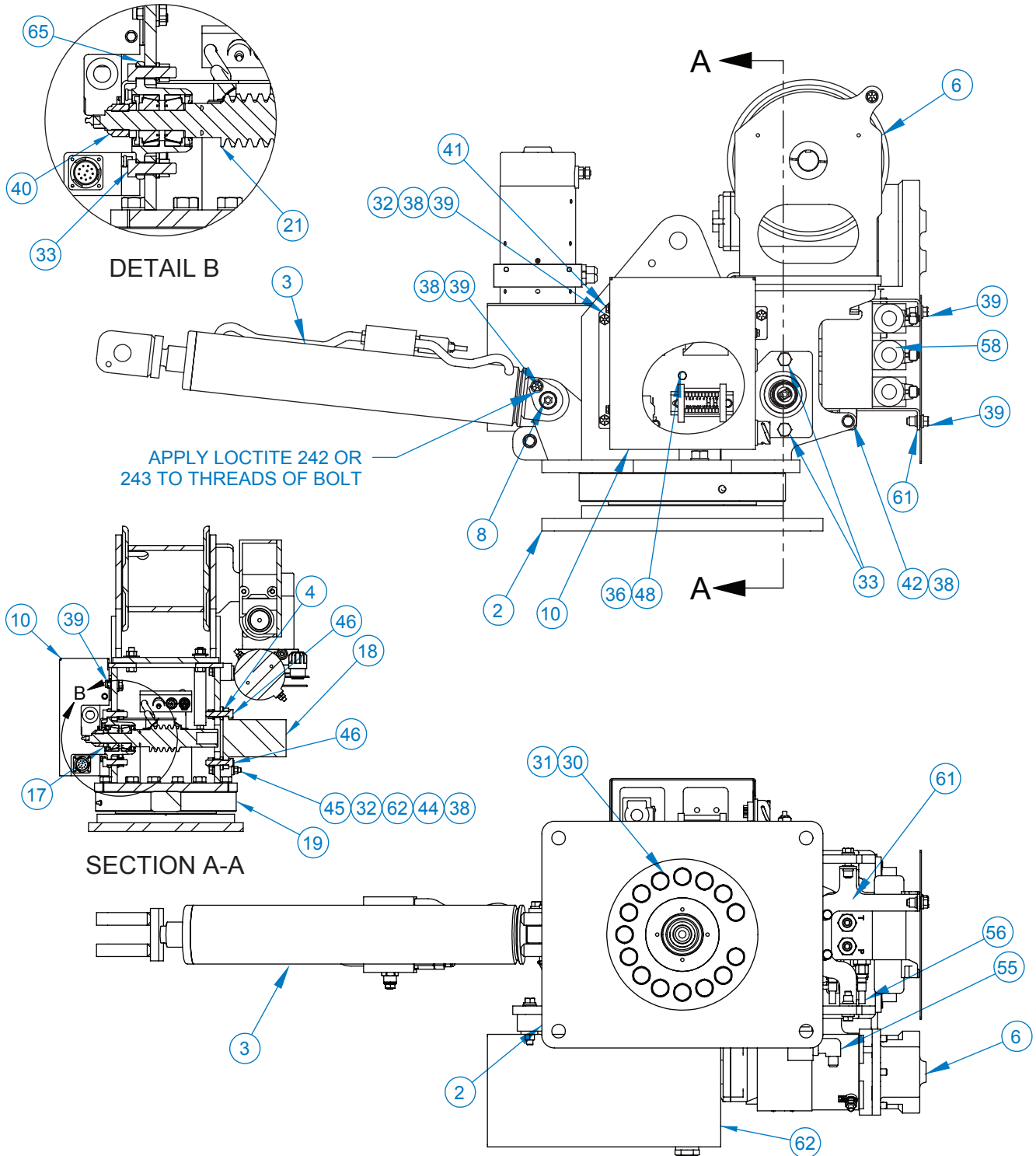



# Pedestal Assembly P/N: 404181002 17

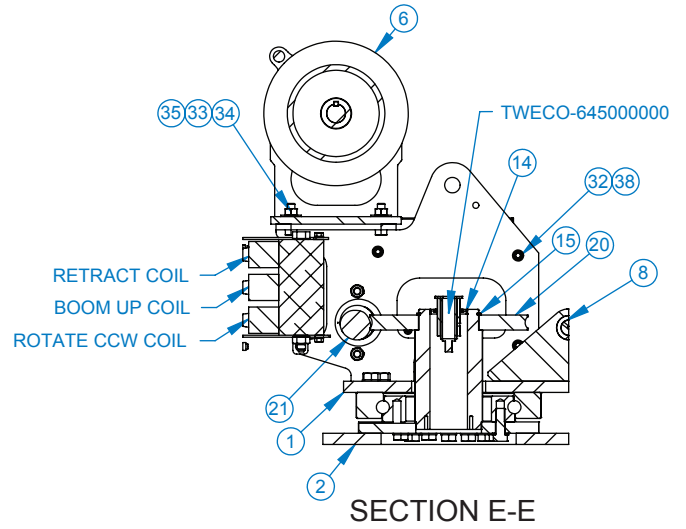
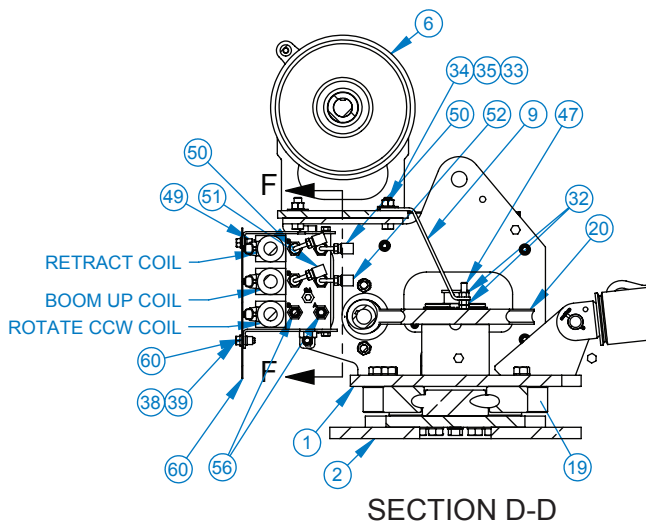
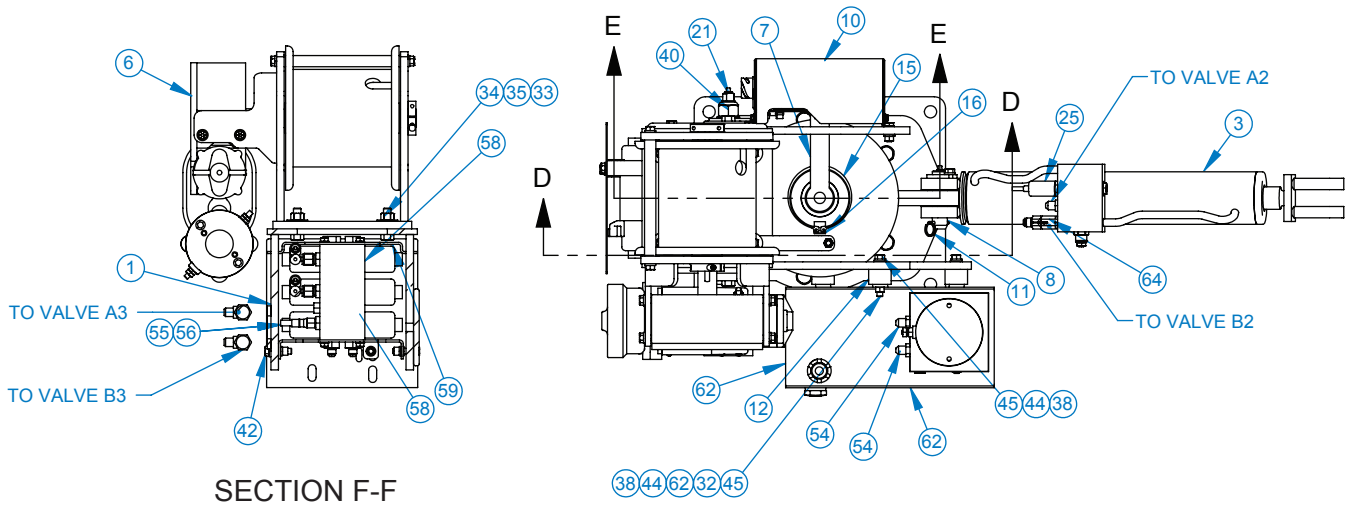

# 17 Pedestal Assembly P/N: 404181002

ITEM NO.	QTY	PART NO.	DESCRIPTION
1	1	404188101	PEDESTAL WELDMNT, 4004EH
2	1	404193000	BASE WLDMNT, 4004
3	1	320845000	CYLINDER, LIFT
4	1	320879000	SPACER ROTATION
5	1	320858000	BEARING, SPHERICAL 1.00 IDv
6	1	113003	HOIST, DCDG-200R, W/ FRAME, ELECTRIC
7	1	404195000	UPPER TWECO BRACKET WLDMT, 4004
8	1	320824000	PIN, LIFT CYLINDER
9	1	404187000	SPRING PLATE, GROUND BRUSH, 4004
10	1	404202000	COVER, RELAY PANEL, 4004
11	1	360678000	PIN, 3/16 COTTERLESS RING
12	3	404214000	SPACER, HYD TANK
13	2	239300000	ZERK, GREASE
14	1	404213000	SEAL, 2.50 OD X 1.5 ID
15	1	404028000	RETAINING RING, SNAP RING
16	1	340602000	KEY, 3/4 SQ X 1
17	1	330483000	SPACER
18	1	366440000	ROTATION MOTOR
19	1	320878000	ROTATION BEARING
20	1	404016000	WORM GEAR
21	1	404015000	WORM SHAFT
22	1	645000000	TWECO, MALE MODIFIED
23	1	600318100	CABLE ASSY, 6 AWG, 24" WIRE LGTH, ø3/8 TMNL, ø5/16 TMNL
24	1	660116000	CABLE ASSY, 6 AWG, 16 1/4" WIRE LGTH, ø3/8 TMNL, ø5/16 TMNL
25	1	404194000	PRESSURE SWITCH, NC, 3200 PSI, 4004
26	1	404197001	RELAY PANEL ASSY, 4004EH
27	1	680155100	KIT, ELECTRICAL, 4004EH
28	4	330252000	SCREW HX HD 5/16-18 UNC X 3/4 LG GR5
29	4	020601000	WASHER SP LK 5/16
30	23	023902000	WASHER FL 5/8 HARDENED
31	23	012198000	SCREW HX HD 5/8-11 UNC X 1 3/4 LG GR8
32	8	330372000	NUT HX 3/8-16UNC
33	6	011603000	SCREW HX HD 1/2-13 UNC X 1 3/4 LG
34	8	017701000	NUT HX 1/2-13 UNC
35	4	021600000	WASHER FL 1/2
36	1	020200000	WASHER SP LK 1/4
37	1	005500000	SCREW HX HD 1/4-20 UNC X 3/4 LG
38	11	021100000	WASHER SP LK 3/8
39	6	330371000	SCREW HX HD 3/8-16 UNC X 1 LG GR8
40	1	019000000	NUT HX NYLK 7/8-14 UNF
41	3	360493000	SCREW HX WHIZ-LK 1/4-20 UNC X 1/2 LG
42	2	009109000	SCREW HX HD 3/8-16 UNC X 1 1/2 LG
43	4	021500000	WASHER, SP LK 1/2
44	3	021200000	WASHER FL 3/8
45	3	404229000	SCR HX HD 3/8-16 UNC X 2 1/2LG, ZINC PL, GR 5
46	2	011608000	SCREW HX HD 1/2-13 UNC X 2 LG

# Pedestal Assembly P/N: 404181002 17

ITEM NO.	QTY	PART NO.	DESCRIPTION
47	1	404198000	SCREW HX HD 3/8-16 UNC X 1 1/2 LG, BRONZE
48	1	736272000	NUTSERT 1/4-20 UNC X .027-.165 GRIP
49	4	736274000	NUTSERT 3/8-16 UNC X .027-.15 GRIP
50	2	812037018	HOSE ASSEMBLY, -6 JIC 90/-4 HOSE
51	1	812037031	HOSE ASSY, -6 JIC/ -6 90 DEG ELL, -4 HOSE x 31" LG
52	1	812037027	HOSE ASSY, -6 JIC/ -6 90 DEG ELL, -4 HOSE x 27" LG
53	2	812209028	HOSE ASSY, -6 HOSE, -6 JIC / -6 JICF 90DEG SHORT, 28" LONG
54	3	200876000	FITTING 6 SAE/6 JIC STRAIGHT
55	2	490198000	FITTING 10SAE(M)/6JIC ELBOW 90
56	2	812026016	HOSE ASSY -4 HOSE -6 FEMALE JIC
57	1	320988275	KIT, HYDRAULIC, 3203 PRX/ 4004
58	1	320989420	VALVE ASSY, 3 SPOOL, NON-PROP, 12 VOLT
59	1	404188008	UPPER VALVE BRACKET, 4004 EH
60	1	366688000	COVER, REAR
61	1	320989203	LOWER VALVE BRACKET, 3203H
62	1	320991307	POWER UNIT, NEXSTAR 3203/4004 EH
63	16	374085000	NYLON HOSE SLEEVE
64	1	320988261	VALVE, FLOW REGULATOR, IN-LINE
65	1	330478000	BEARING HOUSING ASSY

# 18 Hoist Assembly P/N: 113003

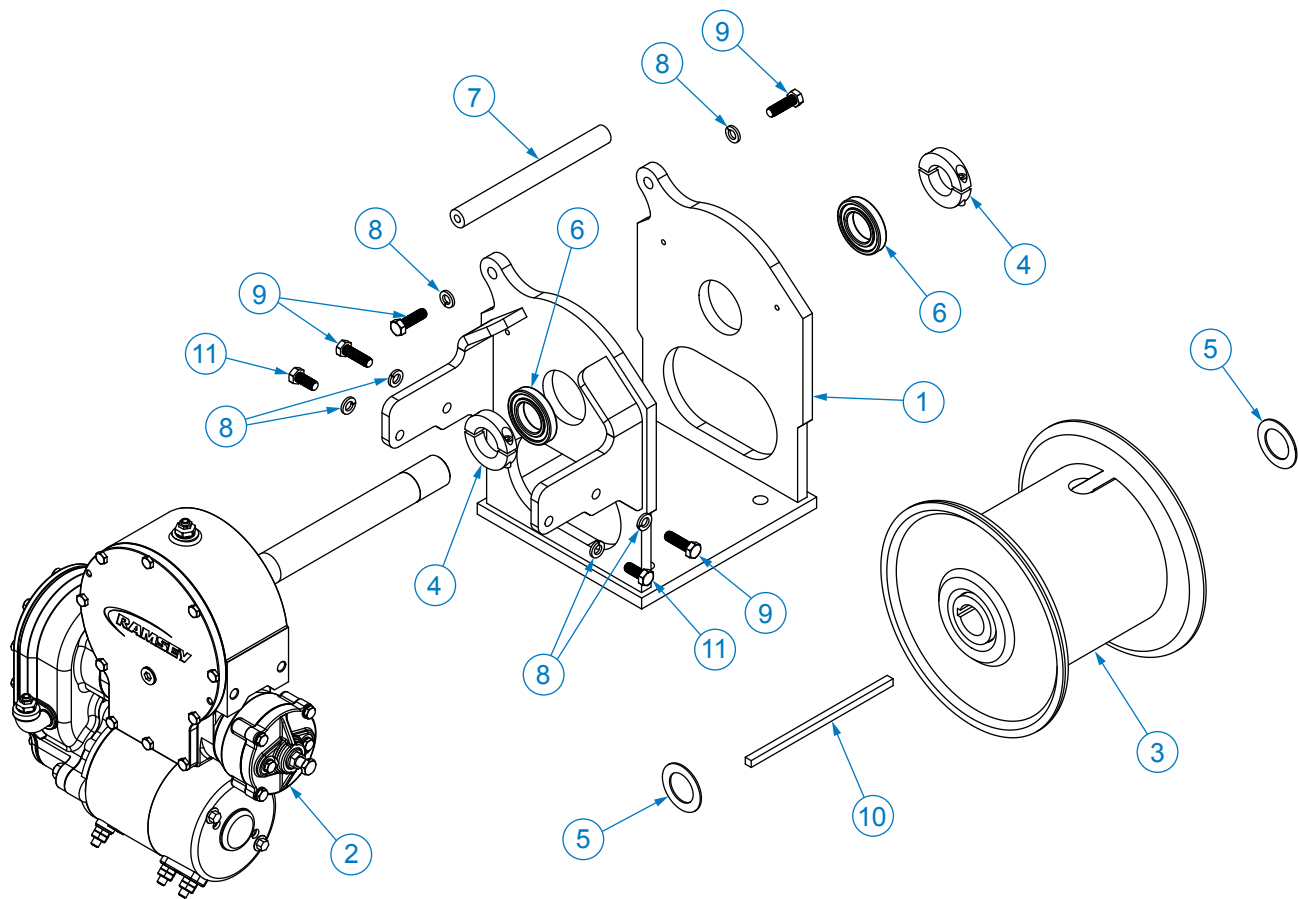

ITEM NO.	QTY	PART NO.	DESCRIPTION
1	1	242177	HOIST FRAME
2	1	297036	GEAR HSG/SPUR GEAR HSG/MTR
3	1	436037	DRUM WELDMENT
4	2	479016	COLLAR, SPLIT 1.25" I.D.
5	2	518063	BEARING, BRONZE
6	2	402128	BEARING 1.25" I.D.
7	1	448100	TIE BAR, HOIST ASSEMBLY
8	6	418177	WASHER SPLK 3/8"
9	4	414316	SCW HX 3/8" UNC X 1-1/4" GR8
10	1	342199	KEY, 5/16" X 7-1/2"
11	2	414294	SCREW, 3/8"-16 NC X 7/8" LG

# Hoist Actuator P/N: 123331 19

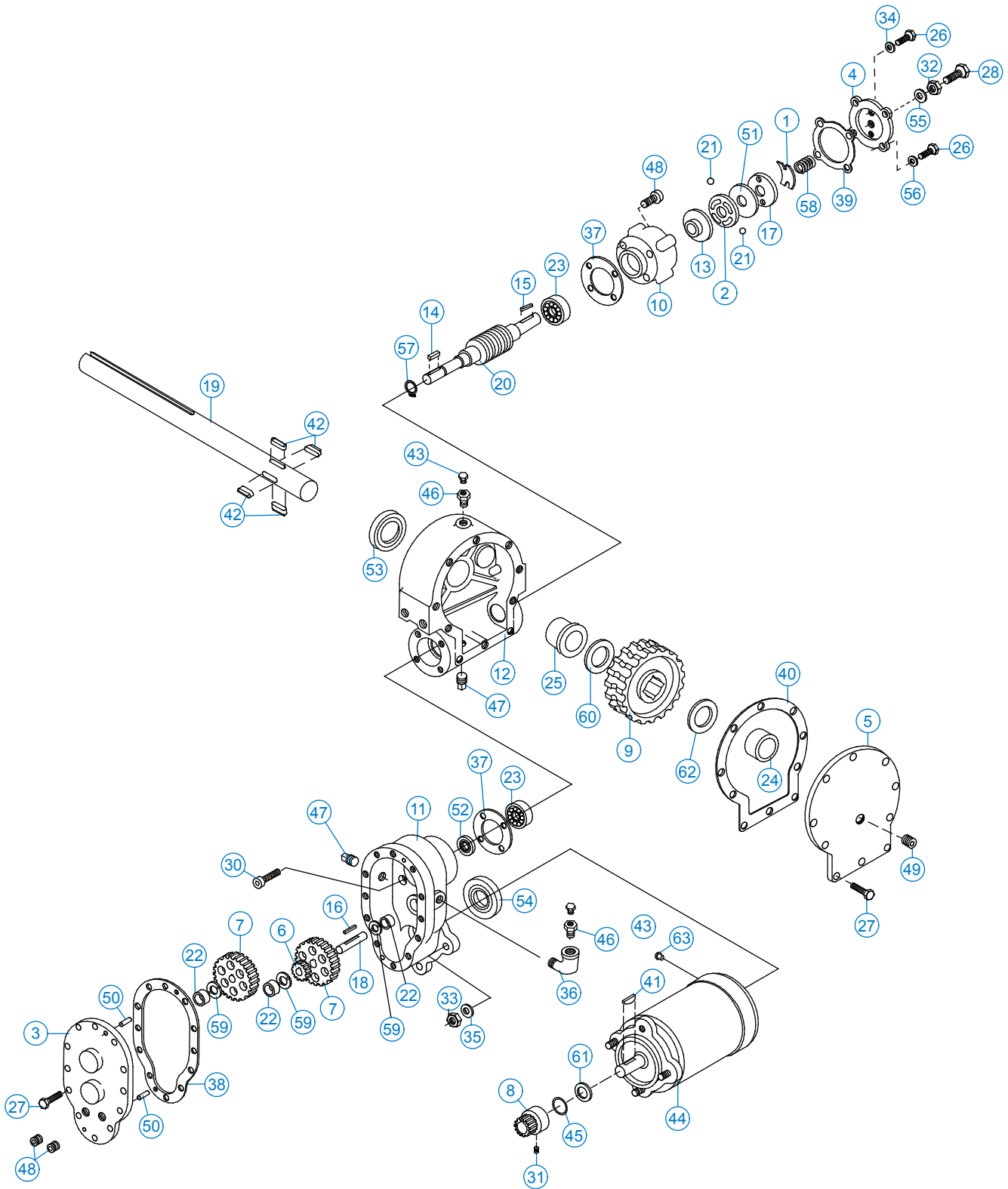

# 19 Hoist P/N: 123331

ITEM NO.	QTY	PART NO.	DESCRIPTION
1	1	306034	SPRING FLAT
2	1	314008	PLATE CAM
3	1	324106	COVER SPUR GEAR HOUSING
4	1	328128	COVER BRAKE
5	1	328134	COVER WORM GEAR HOUSING
6	1	334001	IDLER GEAR
7	2	334003	SPUR GEAR
8	1	334129	PINION GEAR
9	1	334165	GEAR WORM RH
10	1	338007	HOUSING BRAKE
11	1	338203	SPUR GEAR HOUSING
12	1	338273	GEAR HOUSING
13	1	340002	HUB BRAKE
14	1	342023	KEY SQ END
15	1	342027	KEY RD END
16	1	342033	KEY SQ END
17	1	352022	PLATE RETAINER
18	1	356901	SHAFT SPUR
19	1	357145	SHAFT OUTPUT
20	1	368200	WORM RH 30:1
21	2	400003	BALL
22	3	402001	BEARING NEEDLE
23	2	402002	BEARING BALL
24	1	412044	BUSHING COVER
25	1	412045	BUSHING HOUSING
26	6	414021	SCREW HX HD 1/4-20 UNC X 1 LG GR5
27	22	414038	SCREW HX HD 1/4-20 UNC X 3/4 LG GR5
28	1	414224	SCREW HX HD 3/8-16 UNC X 1 1/2 LG GR5
29	4	414821	SCREW SOC BTN HD 1/4-20 UNC X 7/8 LG
30	4	414845	SCREW SOC HD 1/4-20 UNC X 1 LG
31	1	416029	SCREW SET
32	1	418036	NUT JAM 3/8-16 UNC
33	3	418040	NUT HX 3/8-24 UNF
34	2	418154	WASHER 1/4 FLAT ALUM.
35	3	418177	WASHER LK
36	1	432011	ELBOW 90 DEG
37	2	442184	GASKET
38	1	442185	GASKET
39	1	442189	GASKET
40	1	442205	GASKET
41	1	450001	KEY WOODRUFF
42	4	450016	KEY BARTH
43	2	456008	RELIEF FITTING
44	1	458108	MOTOR 12V
45	1	462015	O-RING
46	2	468002	REDUCER

ITEM NO.	QTY	PART NO.	DESCRIPTION
47	2	468011	PIPE PLUG SQ HD
48	2	468017	PIPE PLUG SOC HD
49	1	468018	PIPE PLUG SOC HD
50	2	470001	PIN
51	1	474001	PLATE THRUST
52	1	486009	OIL SEAL
53	1	486017	OIL SEAL
54	1	486023	OIL SEAL
55	1	486069	THREAD SEAL
56	4	486070	THREAD SEAL
57	1	490003	SNAP RING
58	1	494007	SPRING
59	3	518002	WASHER THRUST
60	1	518015	WASHER THRUST
61	1	518018	FIBER WASHER
62	1	518040	WASHER THRUST
63	1	480015	RIVET PLASTIC

# 20 Boom Assembly P/N: 404240100

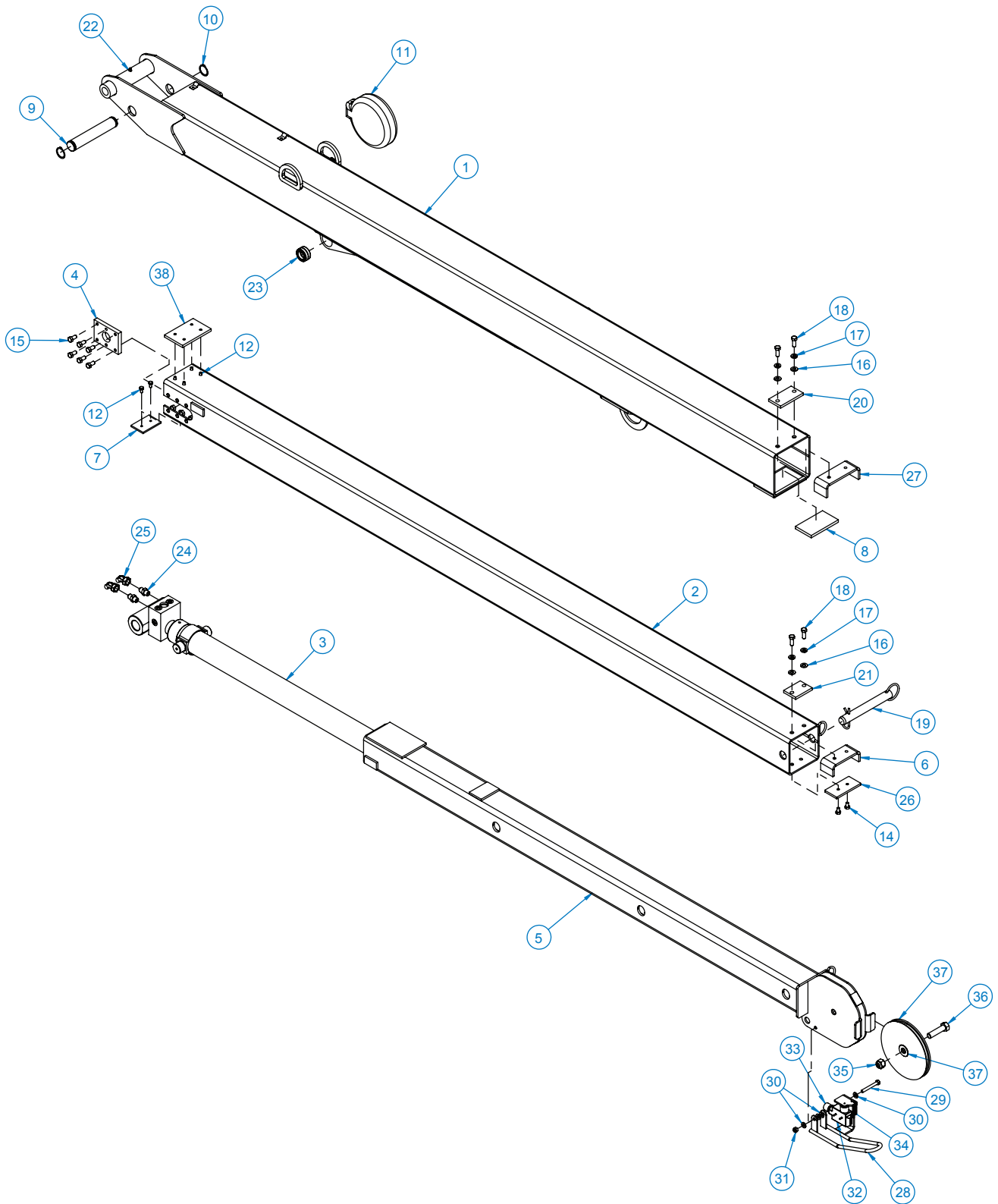



# Boom Assembly P/N: 404240100 20

ITEM NO.	QTY	PART NO.	DESCRIPTION
1	1	404240002	LOWER BOOM WELDMENT, 4004EH (20FT)
2	1	404240004	MID BOOM WELDMENT, 4004EH (20FT)
3	1	404240010	CYLINDER, EXTENSION, 72 INCH STROKE
4	1	366184000	RETAINER, EXTENSION CYLINDER
5	1	404186010	UPPER BOOM WLDMT 4004, SINGLE SHEAVE
6	1	366112000	STOP UPPER BOOM
7	1	480120000	KB PAD
8	1	360791000	WEAR PAD 4.5 X 2.63 X .35
9	1	404204000	PIN 1-1/4 DIA X 7.163 LG, 4004
10	2	480029000	RING RETAINING
11	1	404205000	CORD REEL ASSY
12	6	005406000	SCREW HX HD 1/4-28 UNF X 1/2 LG
13	2	020600000	WASHER 5/16 LOCK SS
14	2	007808000	SCREW 5/16-24 UNF X 1/2 LG
15	12	008400000	SCREW HX HD 3/8-16 UNC X 3/4 LG GR 5
16	4	021200000	WASHER FL 3/8
17	4	021100000	WASHER SP LK 3/8
18	4	008800000	SCREW HX HD 3/8-24 UNF X 1 LG
19	1	366190000	PIN ASSY W/LANYARD
20	1	366201000	WEAR PAD 3.75 X 2.00 X .313
21	1	366202000	PAD, BOOM TOP
22	1	239000000	ZERK DRIVE GR
23	1	320858000	BEARING, SPHERICAL 1.00 ID
24	2	200876000	FITTING 6 SAE/6 JIC STRAIGHT
25	2	330647000	FITTING -6JIC SWIVEL NUT 45 DEG ELBOW
26	1	366199000	PAD BOOM
27	1	366183000	STOP CENTER BOOM
28	1	320871000	BAIL WELDMENT
29	1	811029000	SCREW HX HD 5/16-18 UNC X 2 1/2 LG
30	4	020901000	WASHER FL 5/16
31	1	016801000	NUT HX NYLK 5/16-18 UNC CP
32	1	646900000	SWITCH, ANTI-TWO BLOCK
33	1	642918000	CORD CONNECTOR
34	1	366678000	SPRING, EXTENSION
35	1	018200000	NUT HX NY LK 5/8-11 UNC
36	1	366393000	SCREW HX HD 5/8-11 UNC X 2 1/2 LG GR8
37	1	320883001	SHEAVE ASSEMBLY, 4004
38	1	320988156	BOOM PAD WITH NUTS, 4.75 X 3 X .313, 3203

# 21 Traveling Block Assembly P/N: 404211050

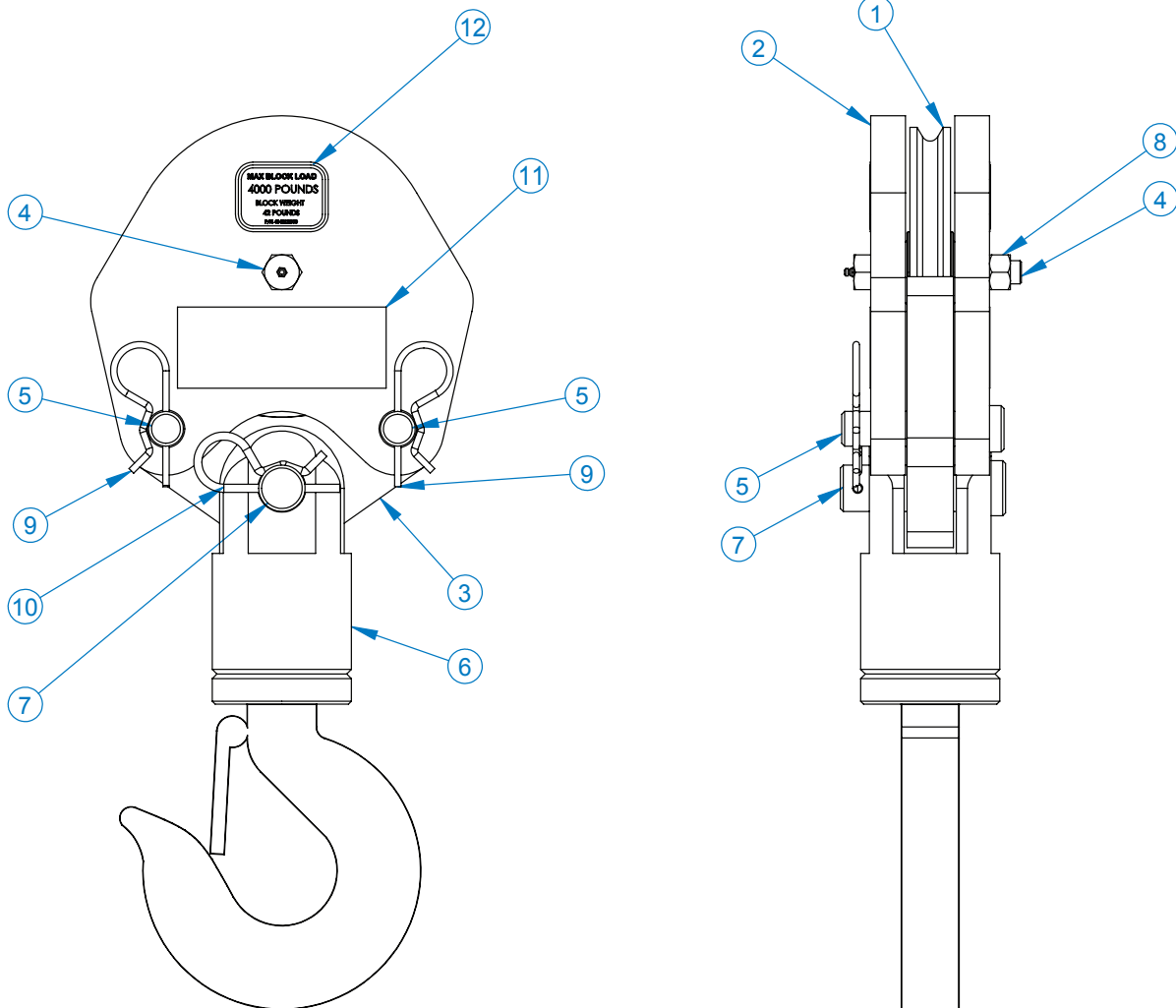

ITEM NO.	QTY	PART NO.	DESCRIPTION
1	1	480130000	SHEAVE ASSY
2	2	480363000	SHORT BLOCK SIDE PLATE
3	1	480364000	TACKLE LOWER
4	1	480372000	BOLT, SHEAVE W/ ZERK FITTING
5	2	480367000	PIN BLOCK
6	1	480371000	HOOK SWIVEL 3 METRIC TON
7	1	480368000	PIN SWIVEL HOOK
8	1	017800000	NUT, HX LK 1/2-20 UNF
9	2	366813000	PIN HITCH
10	1	360124000	PIN HITCH
11	2	040518000	DECAL STAY CLEAR OF LOAD
12	2	404212000	DECAL MAX BLOCK LOAD 4004

# TWECO with Switch Mount P/N: 404218000 22

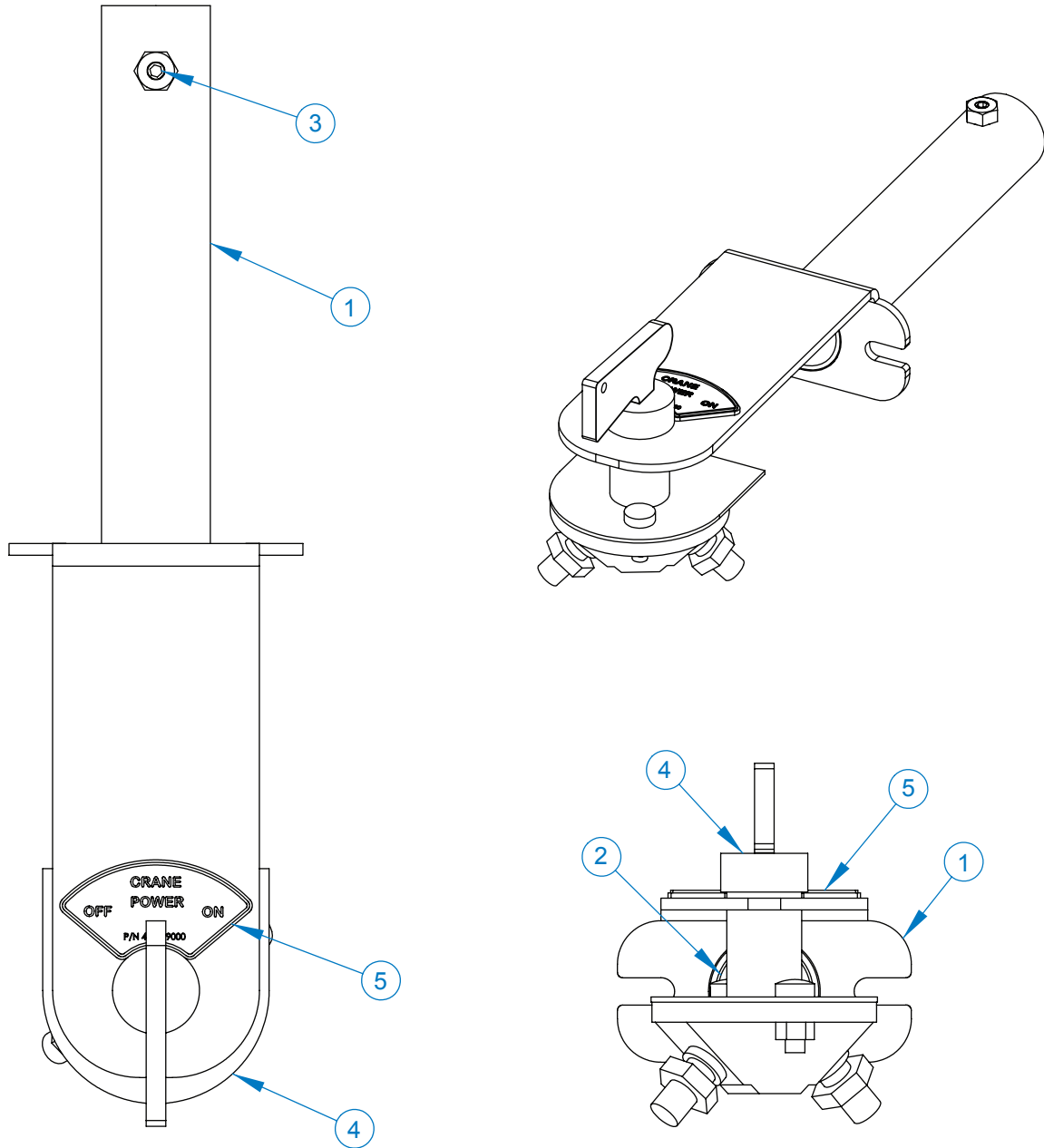

ITEM NO.	QTY	PART NO.	DESCRIPTION
1	1	404217000	LOWER TWECO WDLMT WITH SWITCH MOUNT
2	1	404224000	CABLE ASSY 11 IN, TWECO TO TERMINAL
3	1	002900000	SCREW SET 0.25-20 X 0.25
4	1	404216000	MASTER SWITCH
5	1	404219000	DECAL, CRANE POWER

## 23 Hydraulic Power Unit P/N: 320991307

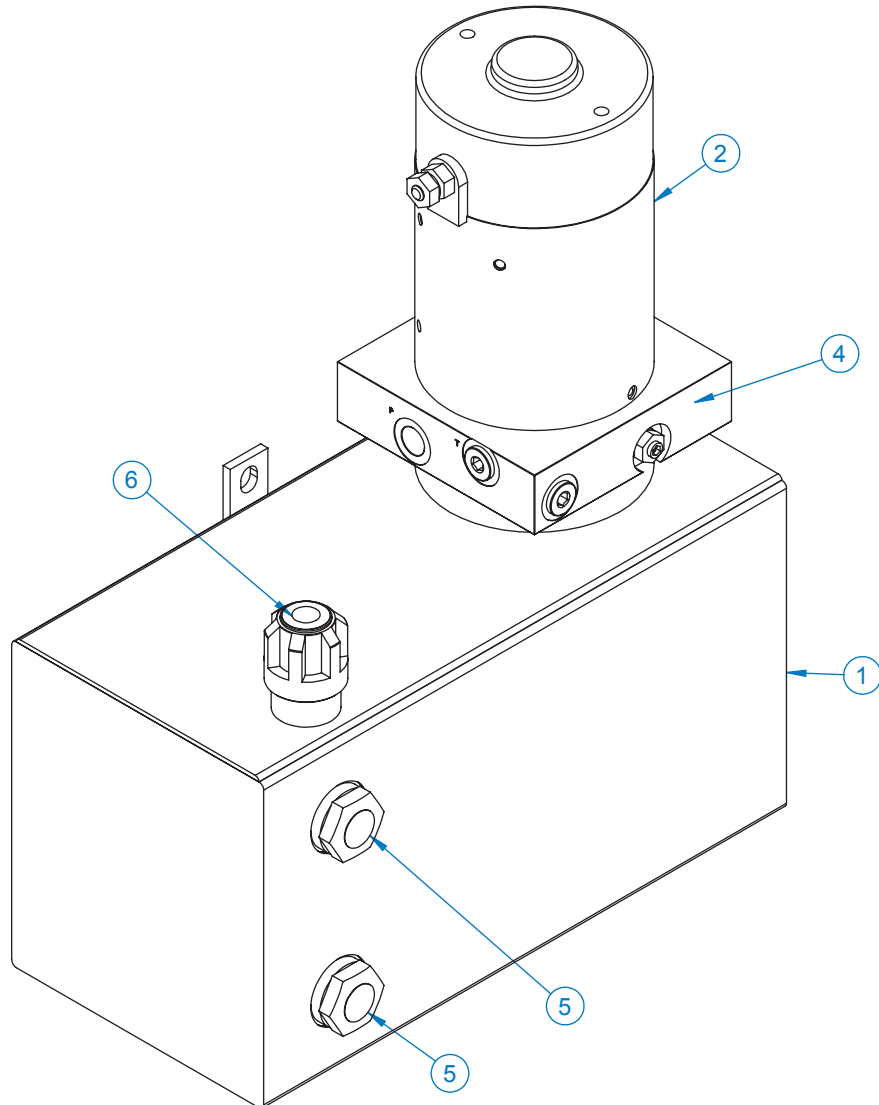

ITEM NO.	QTY	PART NO.	DESCRIPTION
1	1	320991305	TANK, NEXSTAR 3203/4004EH
2	1	320991271	MOTOR, NEXSTAR 3203/4004EH
3	1	320991286	PUMP, 3203/4004EH
4	1	320991284	BASE ASSEMBLY USED W/320991270
5	2	320991274	GLASS, SIGHT USED W/320991270
6	1	320991275	CAP, FILLER USED W/320991270
7	1	320991277	VALVE, RELIEF USED W/320991270
8	1	320991285	O-RING USED W/ 320991270

# Hydraulic Control Valve P/N: 320989420 24

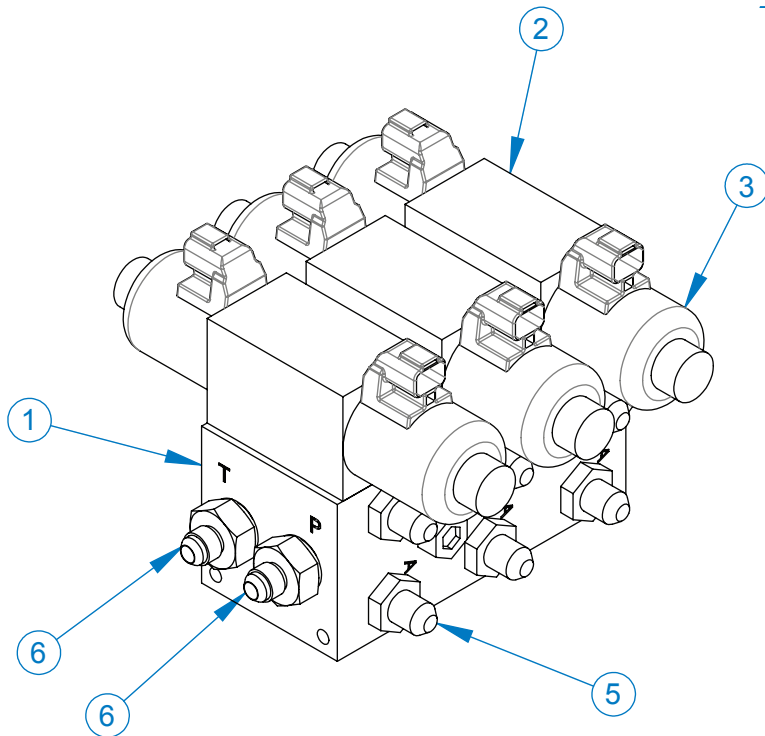
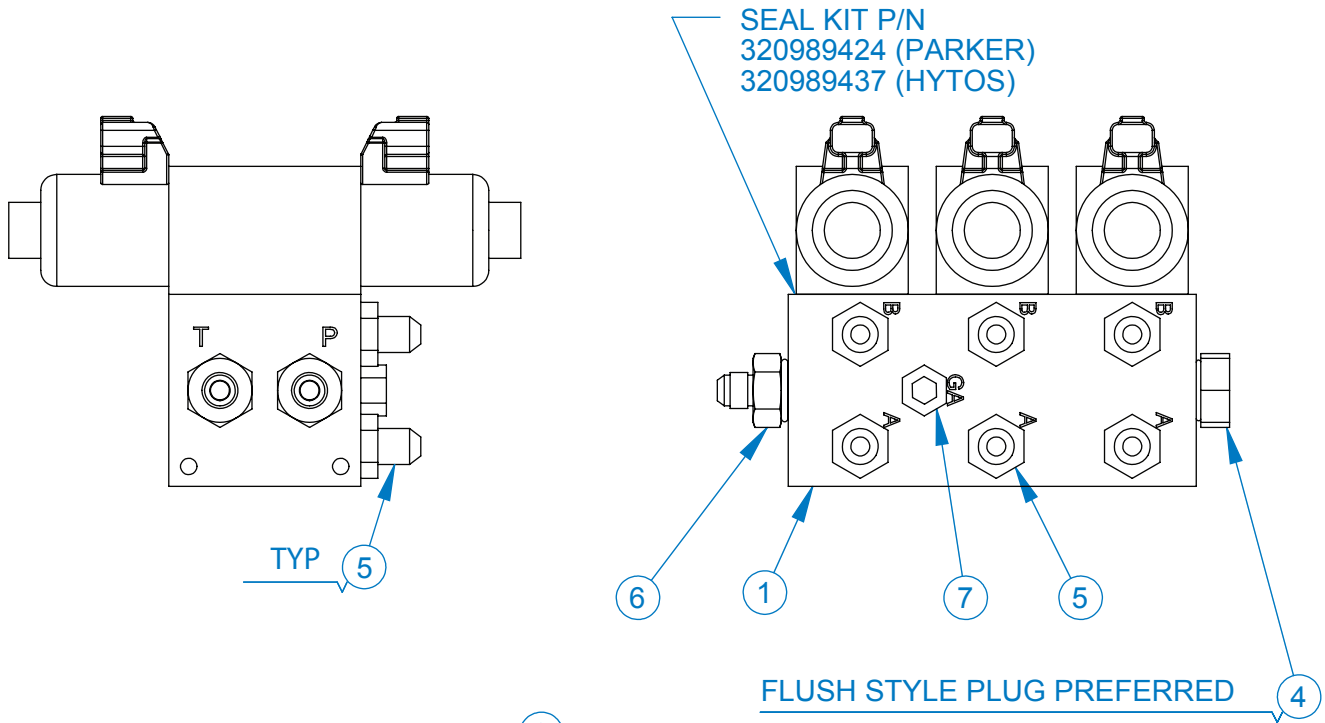

REPLACEMENT COILS:  
PARKER (BLACK) = 320989423  
HYTOS (STEEL) = 320989429  
EATON = 320989432

# 24 Hydraulic Control Valve P/N: 320989420

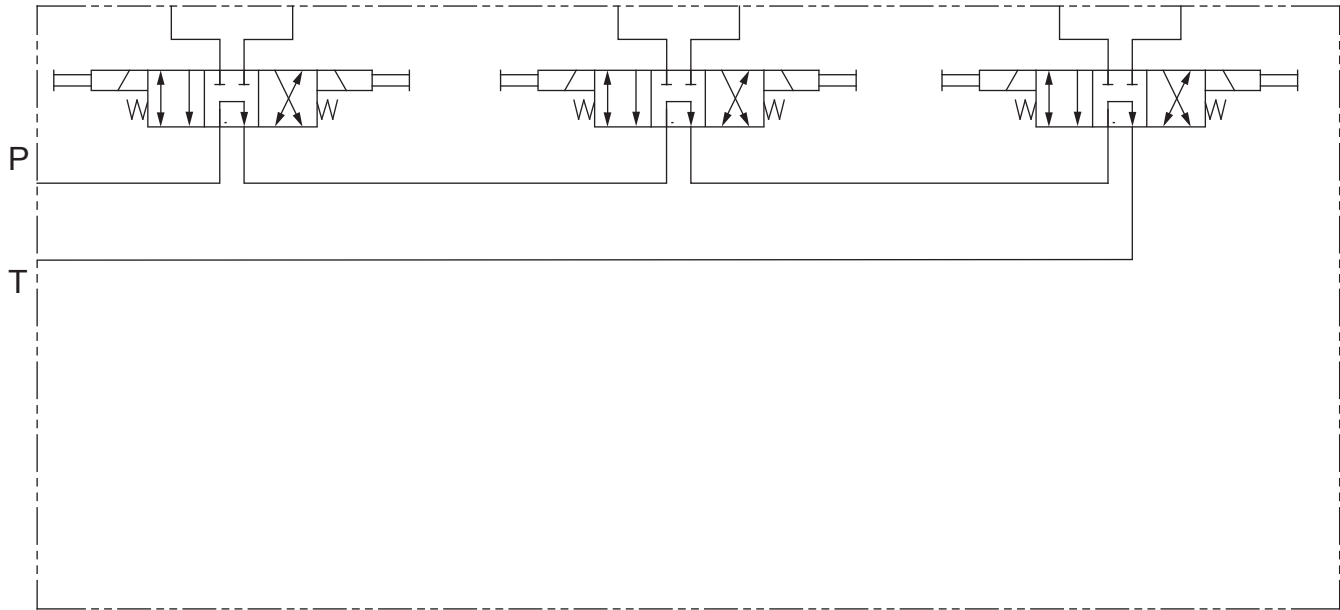

ITEM NO.	EATON QTY.	HYTOS QTY.	PARKER QTY.	AUTO CRANE PART NO.	DESCRIPTION
1	1	-	-	320989430	MANIFOLD BLOCK
	-	1	1	320989430	MANIFOLD BLOCK, DO3
2	-	-	1	320989422	VALVE, DO3 STACK TYPE, PARKER
	-	3	3	320989428	VALVE, DO3 STACK TYPE, HYTOS
	3	-	-	320989431	VALVE, DO3 STACK TYPE, EATON
3	-	-	6	320989423	COIL, 12V-2.5A PARKER, FOR 320989420
	-	6	-	320989429	COIL, 12V-2.7A HYTOS, FOR 320989420
	6	-	-	320989432	COIL, 12V-2.5A EATON, FOR 320989420
4	2	2	2	330072000	PLUG, #10 SAE
5	6	6	6	202756	FITTING 6-8 STRAIGHT
6	2	2	2	202755000	FITTING, -10 SAE/-6 JIC, STR
7	1	1	1	751034000	PLUG, -6ORB

# Relay Panel P/N: 404197001 25

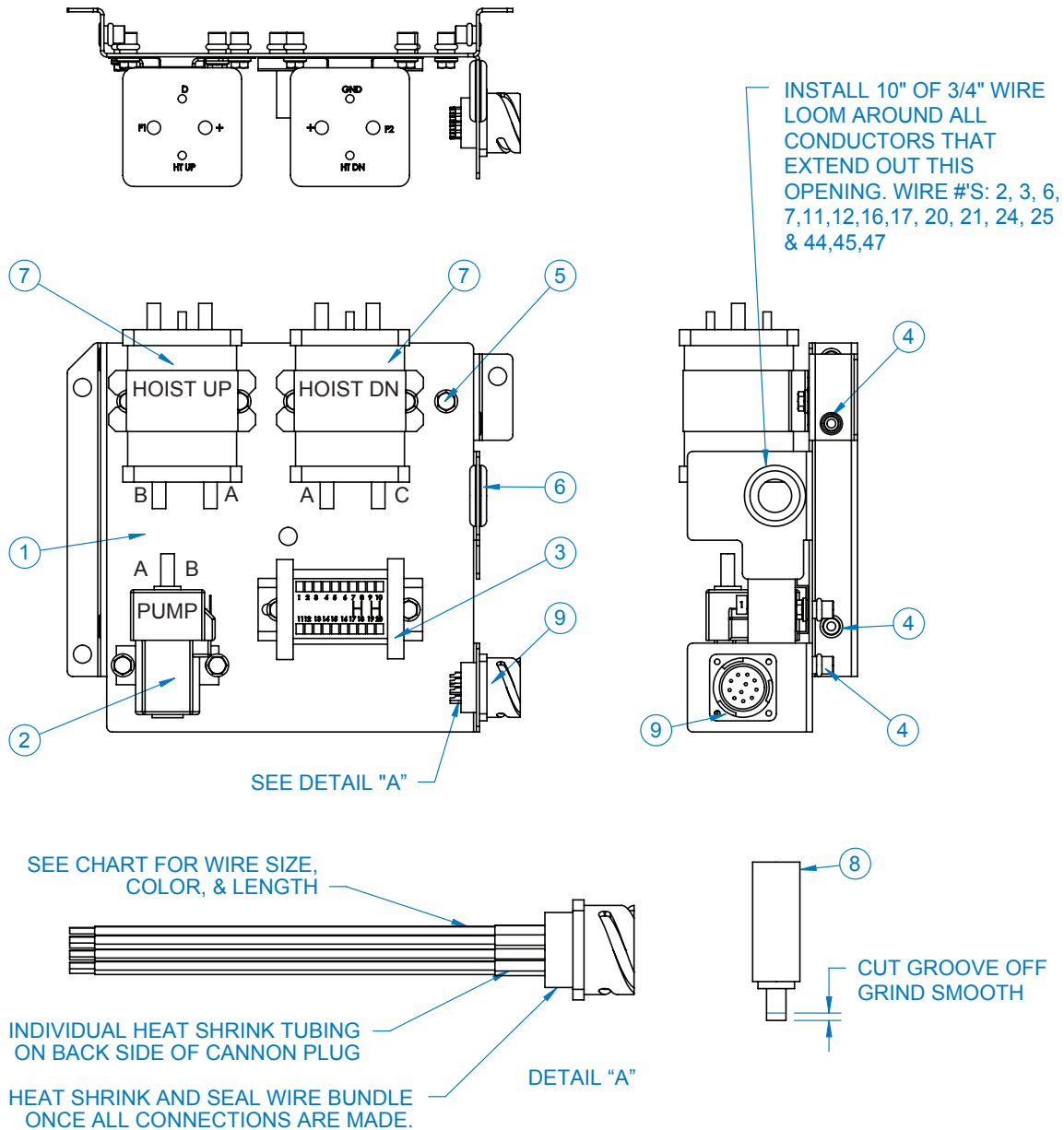

ITEM NO.	QTY	PART NO.	DESCRIPTION
1	1	404203001	BRACKET, RELAY PANEL, 4004
2	1	320584	RELAY, POWER UNIT
3	1	320803000	TERMINAL STRIP 10
4	12	736272	NUTSERT 1/4-20UNC X .027-.165 GRIP
5	10	360493000	SCREW HX WHIZ-LK 1/4-20UNC X 1/2 LG
6	1	371024	GROMET 3/4" I.D.
7	2	404167	SOLENOID, SEALED
8	1	645000	TWECO, MALE MODIFIED
9	1	320562	RECEPTACLE, 11 PIN BAYONET

# 25 Relay Panel P/N: 404197001

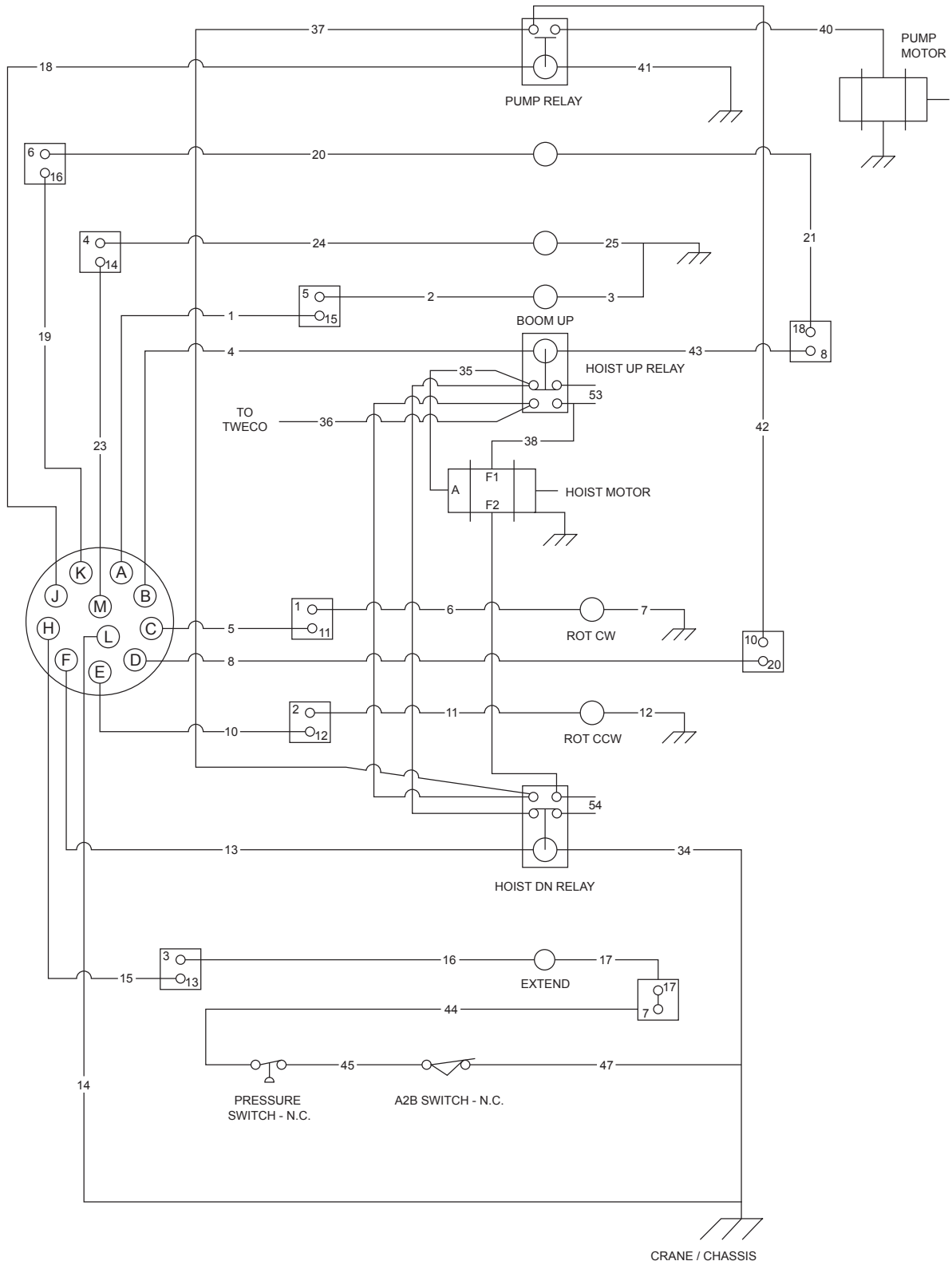





P.O. Box 580697 Phone: (918) 438-2760  
4707 N. Mingo Rd. Tulsa, OK 74158-0697

## LIMITED WARRANTY

### 1 YEAR PURCHASED REPLACEMENT PARTS

Auto Crane will warranty to the consumer for a period of (1) year from the date that a new Auto Crane replacement part was purchased from an authorized Auto Crane distributor. Each new Auto Crane part they sell will be free under normal use and service from defects in material and workmanship. Date of purchase will be honored as the date indicated on the Bill of Sale to the consumer.

The obligation of Auto Crane under this warranty does not apply to parts replaced under the limited warranty for a new Auto Crane product. The warranty for parts replaced under the limited warranty of a new Auto Crane product expires when the warranty for that product expires.

The obligation of Auto Crane under this warranty is limited to the replacement or repair of purchased replacement parts that appear to the manufacturer to be defective after review of documentation (Auto Crane Warranty Claim Form, photos, data etc.) provided by the Auto Crane distributor and/or inspection of parts returned to Auto Crane. This warranty does not obligate Auto Crane to bear labor costs to replace the defective parts or travel time charges in connection with the replacement or repair of defective parts. Responsibility for customer's claims arising from misapplication, abuse, misuse or alteration of equipment or parts lies with the distributor or user and no warranty obligation is assumed in these circumstances by Auto Crane.

Auto Crane will in no event be liable for any consequential damages or contingent liabilities arising out of the failure of any Auto Crane product or parts to operate properly

Auto Crane makes no warranty in respect to parts for component accessories, it being subject to the warranties of their respective manufacturers.

If field service, at the request of the distributor, is rendered and fault is found not to be with Auto Crane's product, the distributor shall pay the time and expense of the field representative.

Claims for service labor or other expenses that have incurred by the buyer without approval or authorization or Auto Crane will not be accepted

When applying for warranty claims may be handled by contacting your nearest authorized Auto Crane **Distributor. All claims are to be filed in writing on an Auto Crane Warranty Claim Form.**

Limited Parts Warranty 1 Year

Effective June 15, 2010



P.O. Box 580697 Phone: (918) 438-2760  
4707 N. Mingo Rd. Tulsa, OK 74158-0697

## LIMITED WARRANTY 2 YEAR PARTS AND LABOR

Auto Crane will warranty to the consumer for a period of (2) years parts and labor from the date of purchase. Each new Auto Crane unit they sell will be free under normal use and service from defects in material and workmanship. Date of purchase will be honored as the date indicated on the Bill of Sale, which must accompany the Warranty Registration and be on file with Auto Crane. Absent a valid Warranty Registration and appropriate documentation, the original date of manufacture, as indicated by the serial number on the product, will be used to determine the effective date of the 2 year warranty.

The obligation of Auto Crane under this warranty is limited to the replacement or repair of parts that appear to the manufacturer after review and/or inspection to be defective and paid flat rate labor for replacing defective parts. This warranty does not obligate Auto Crane to bear the travel time charges in connection with the replacement or repair of defective parts. Responsibility for customer's claims arising from misapplication, abuse, misuse or alteration of equipment or parts lies with the distributor or user and no warranty obligation is assumed in these circumstances by Auto Crane.

Auto Crane will in no event be liable for any consequential damages or contingent liabilities arising out of the failure of any Auto Crane Product or parts to operate properly.

Auto Crane makes no warranty in respect to component accessories, it being subject to the warranties of their respective manufacturers.

If field service, at the request of the distributor, is rendered and fault is found not to be with Auto Crane's product, the distributor shall pay the time and expense of the field representative.

Claims for service labor or other expenses that have incurred by the buyer without approval or authorization or Auto Crane will not be accepted.

When applying for warranty, claims may be handled by contacting your nearest authorized Auto Crane Distributor. All claims are to be filed in writing on an Auto Crane Warranty Claim Form.

**AUTO CRANE COMPANY IS UNDER NO OBLIGATION TO EXTEND THIS WARRANTY TO ANY CUSTOMER FOR WHICH AN AUTO CRANE DELIVERY REPORT FORM HAS NOT BEEN COMPLETED AND ON FILE WITH AUTO CRANE COMPANY**

Limited Warranty 2 Years

Effective September 2, 2003



EHC-4 HW/FM